

CONCERT MARIMBA

YM-5104A YM-5100A YM-4900A YM-4600A

取扱説明書

Owner's Manual

Benutzerhandbuch

Mode d'emploi

Manual de instrucciones

Manual do Proprietário

Руководство пользователя

使用说明书

사용설명서

使用説明書

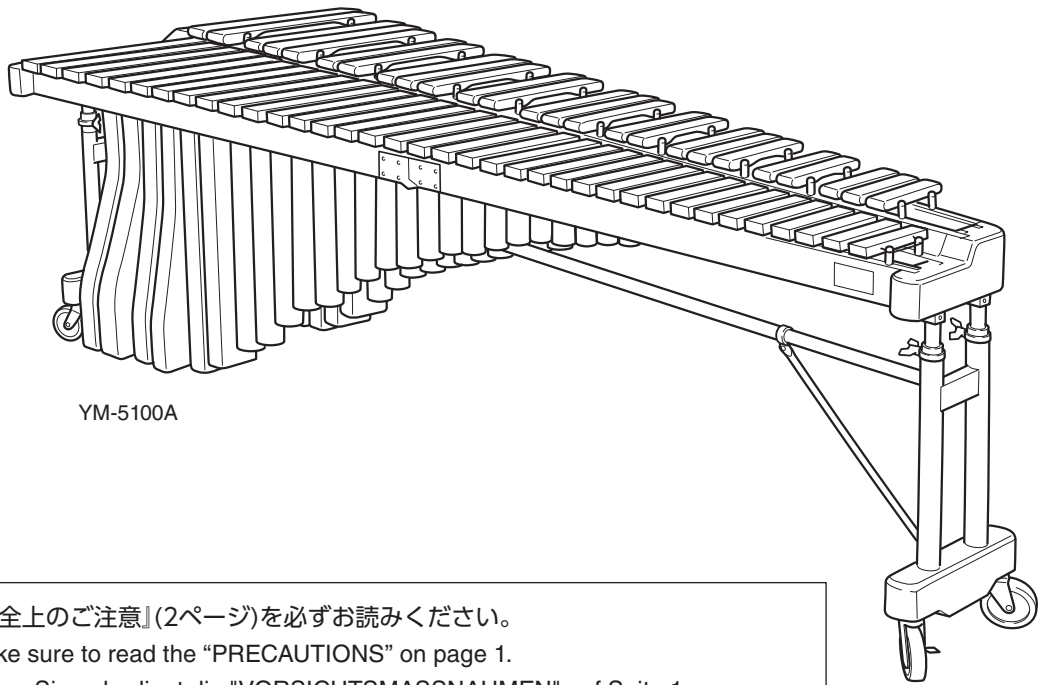

YM-5100A

『安全上のご注意』(2ページ)を必ずお読みください。

Make sure to read the "PRECAUTIONS" on page 1.

Lesen Sie unbedingt die "VORSICHTSMASSNAHMEN" auf Seite 1.

Assurez-vous de lire "PRÉCAUTIONS D'USAGE" à la page 1.

Asegúrese de leer "PRECAUCIONES" en la página 1.

Certifíque-se de ler "PRECAUÇÕES" na página 1.

Обязательно прочтите разделы «ПРАВИЛА ТЕХНИКИ БЕЗОПАСНОСТИ» на стр. 1.

务 请阅读 第 1 页 “ 注意事项 ”。

1 페이지의 “안전 주의사항” 을 반드시 읽어 주십시오 .

請務必詳閱第 1 頁的「注意事項」。

PRECAUTIONS

PLEASE READ CAREFULLY BEFORE PROCEEDING

Please keep this manual in a safe and handy place for future reference.

CAUTION

Always follow the basic precautions listed below to avoid the possibility of physical injury to you or others, or damage to the instrument or other property. These precautions include but are not limited to the following:

Do not disassemble

- Repairs or part replacement should not be attempted unless relevant instructions are provided in the manual.
- Do not disassemble the gas spring. Since high-pressure gas is sealed inside the gas spring, any attempt to disassemble it is dangerous and creates a high risk of injury.

Assembly

- Assemble (or disassemble) the instrument on a flat, sturdy surface. If you place it on an unstable surface, such as on a wobbly platform, or on a tilted or uneven surface, the instrument might fall.
- Assemble the instrument in the proper sequence by following the assembly instructions in this manual. Also, be sure to tighten the screws or bolts regularly. Failure to do so may result in damage to the instrument or cause the instrument to overturn, possibly causing injury.
- When assembling the instrument, be careful not to get your fingers pinched. In particular, when assembling the rails and resonators, two people must work together while checking each step carefully.

Transportation and Installation

- When assembling or moving the instrument, always use two or more people. Failure to do so might result in damage to the instrument or the instrument overturning, possibly causing injury.
- Do not place the instrument in an unstable position where it might accidentally fall over.
- Do not carry the assembled instrument up or down stairs. Doing so is dangerous as parts might fall, or you might lose your balance and fall. Be sure to transport the instrument disassembled.
- Lock both left and right casters except when moving or transporting the instrument. Failure to do so might result in the instrument moving or overturning, possibly causing injury.
- The instrument should be moved only across smooth, flat surfaces when using the casters. On a sloped, unstable or gravel surface, the instrument may overturn or run out of control, and possibly cause injury.

- Never run when moving or transporting the instrument using the casters. Doing so may result in the instrument hitting an obstacle or wall and causing serious injury.
- If you are planning to transport the instrument by car, disassemble it to its original condition at the time of purchase (see page 4), and pack it securely. Transporting the instrument without packing might result in damage to it. To disassemble the instrument, follow the assembly procedure in reverse order.
- Do not go near the instrument during an earthquake. Strong shaking during an earthquake could cause the instrument to move or tip over, resulting in damage to the instrument or its parts, possibly causing injury.

Handling

- Do not place anything on top of the instrument. Doing so might cause the tone bars or the rails to become distorted or deformed.
- When the instrument rattles, makes noise or vibrates, immediately stop using it, and tighten all screws again. Failure to do so may result in the instrument overturning and could possibly cause injury.
- Replace any cracked tone bars immediately. The end of a cracked tone bar can be very sharp, and might cut your hands.
- Do not use the mallet for any purpose other than playing the instrument. Otherwise, it might cause injury or other accidents. Be careful to ensure that children do not use the mallet to hit other individuals, place the mallet in their mouth, or do other dangerous things.
- Never insert your hands or feet into moving parts such as under the casters. Otherwise, they might be caught and injured.
- Do not play around the instrument. Doing so may cause you to bump into the instrument, possibly resulting in injury. It also may cause the instrument to overturn. Do not allow children to play around the instrument.
- Do not lean, rest your weight, or place heavy objects on the instrument. Doing so may result in the instrument overturning, cause damage to the tone bars or frame, or injury to you or others.

Yamaha is not responsible for damage caused by improper use or modifications to the instrument.

NOTICE

To avoid damage to the product, follow the advice below.

■ Handling

- Do not handle this product roughly. Otherwise, the product may be damaged.
- Use a mallet suitable for playing the marimba. Playing the instrument with an inappropriate mallet might cause dents or scratches on the tone bars, or cause them to go out of tune.
- Do not use the instrument in locations with poor ventilation.
- When moving the instrument, make sure all caster stoppers are released. Lift the instrument slightly whenever moving it over surfaces that are not smooth or flat.
- When moving the instrument, move it gently avoiding shocks and impacts. The instrument is sensitive to shocks and may be damaged.
- If the instrument is moved frequently, screws, parts, etc., may become loose. After moving the instrument, check to make sure all screws, parts, etc., are firmly fastened. Firmly tighten all loose items.

- Do not apply excessive force to lift the frame end as it may pull the gas spring off from the leg.
- Do not use or store the instrument in the following locations. Doing so might cause the instrument to malfunction.
 - Places subject to extremely high temperatures (places exposed to direct sunlight, near heating equipment, etc.)
 - Places subject to extremely low temperatures
 - Near moisture (bathroom, wet floor, etc.) or places subject to high humidity
 - Places exposed to rainwater
 - Places with a lot of dust
 - Places subject to extensive vibration

■ Maintenance

- To clean the tone bars, use a dry, soft cloth or silicone cloth. Never use thinner, benzene, or wet cloth. Doing so might cause damage to the instrument, such as corroding the surface coating of the tone bars.

INFORMATION

■ About this manual

- The illustrations in this manual are for instructional purposes only, and may appear somewhat different from your instrument.
- Company names and product names in this manual are the trademarks or registered trademarks of their respective companies.

Thank you for purchasing a Yamaha concert marimba. We at Yamaha are forever striving to create instruments you can play with ease to produce beautiful sounds. We have made extensive efforts to select high quality materials in the creation of these outstanding musical instruments. We hope you will enjoy playing your Yamaha concert marimba, which produces deep, rich sounds that can project and fill a room with a dynamic range of volume. This manual explains how to use your Yamaha concert marimba properly. Please read this manual thoroughly to ensure that your new instrument will provide you with rich musical enjoyment for many years to come.

NOMENCLATURE

■ YM-5104A YM-5100A YM-4900A YM-4600A

* The illustration shows model YM-5100A.

* The YM-5100A is used for illustrative purposes in this manual. For this reason, the illustrations may not match with the YM-5104A, YM-4900A, and YM-4600A.

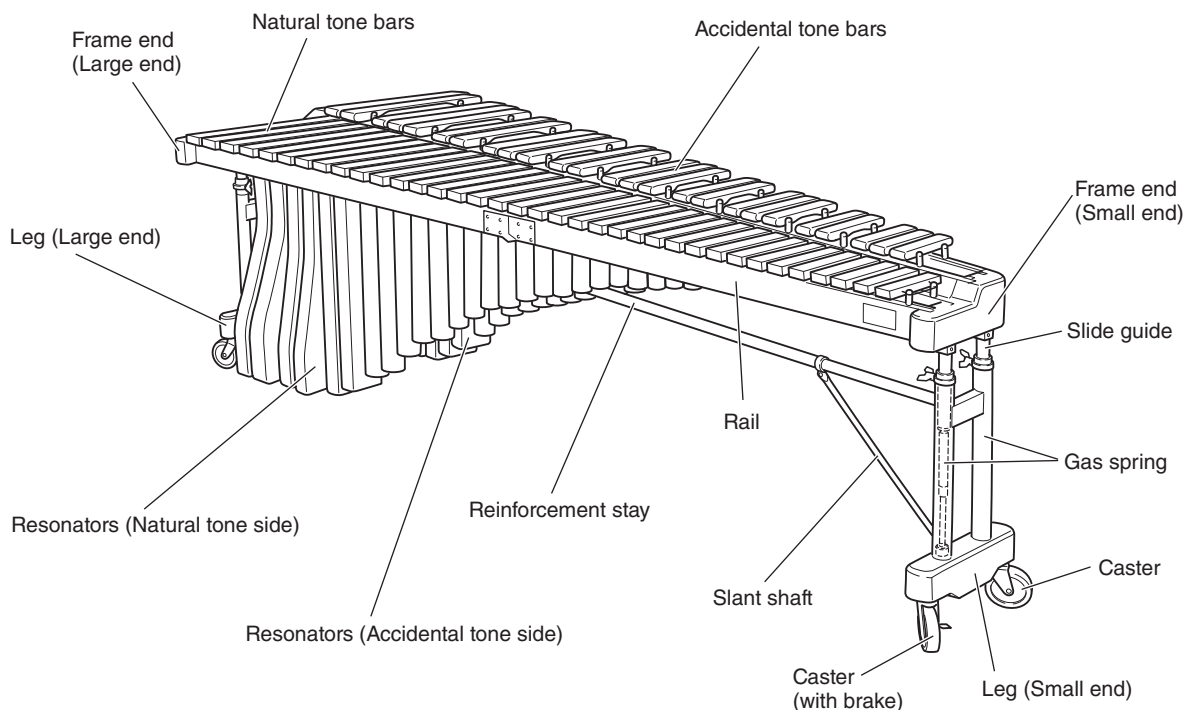

PACKAGE CONTENTS

The shipping carton for your marimba should contain the parts shown below.

* The rails and resonators in the packages are folded.

Before assembling the instrument, confirm that all listed parts are included.

* In the event that a part is missing, please contact the shop where the instrument was purchased.



• Be careful not to get your fingers caught when opening the rail and resonator packages.

① **Natural tone bars**

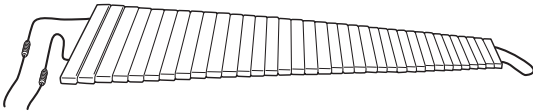

② **Accidental tone bars**

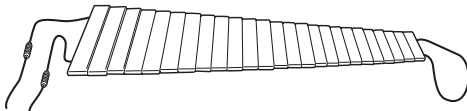

③ **Resonators (Natural tone side)**

Each resonator for the natural tone side is closed on the bottom.

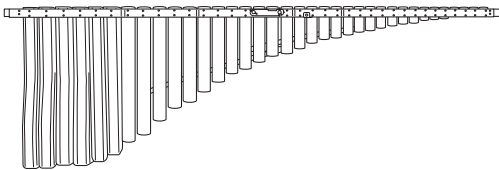

④ **Resonators (Accidental tone side)**

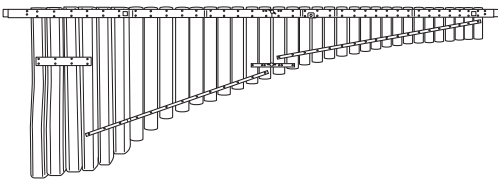

⑤ **Reinforcement stay**

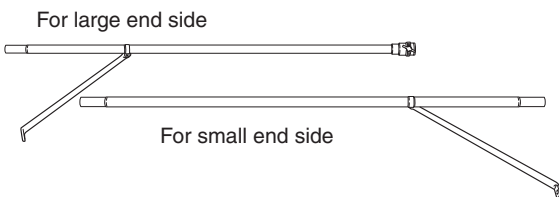

⑥ **Rail (1)**

Marking on the end face (A).



⑦ **Rail (2)**

Marking on the end face (B).



⑧ **Rail (3)**

Marking on the end face (C).



⑨ **Rail (4)**

Marking on the end face (D).

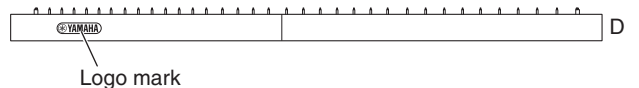

⑩ **Leg (Large end)**

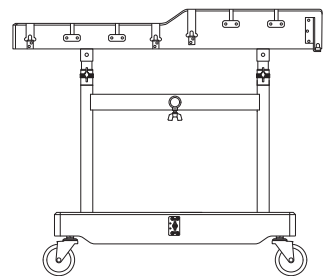

⑪ **Leg (Small end)**

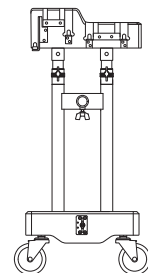

ASSEMBLY



- For safety, assembly should be performed by two or more people in a place that provides sufficient space.
- Be careful not to pinch your fingers when assembling the instrument. In particular, when assembling the rails and resonators, two people must work together while checking each step carefully.

1 Connect the large and the small end legs using the reinforcement stays.

* Before proceeding to the next step, make sure that the slide guide fixing bolts of the large and small end legs are securely fastened.



- Do not loosen the side guide fixing bolts at this stage. Loosening them would cause a sudden rise of the frame end, which could be very dangerous.

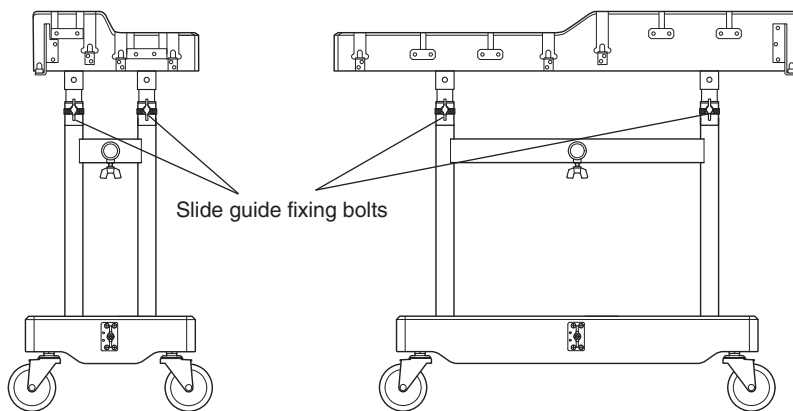

1-1 Place the large and small end legs and reinforcement stays so that they will be positioned as illustrated below after assembly.

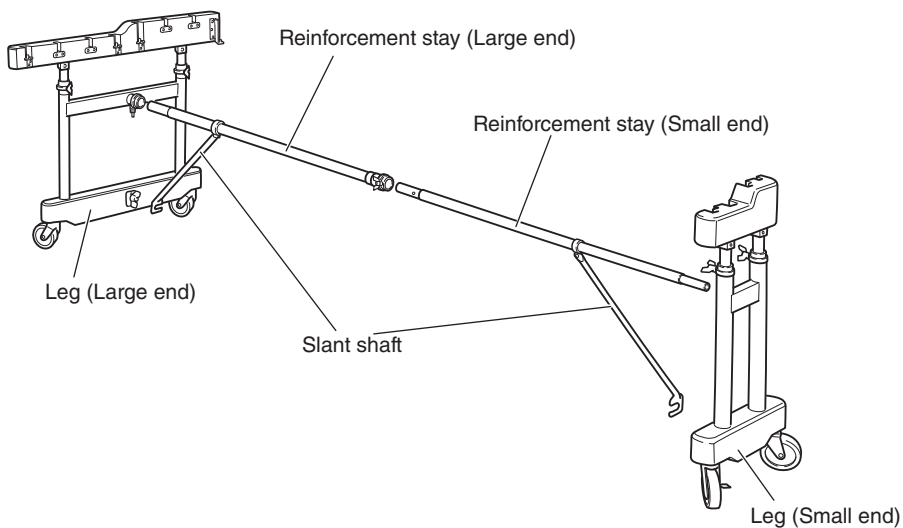

ASSEMBLY

- 1-2 Connect the reinforcement stays at the center. Align the end of the fixing bolt and the holes in the reinforcement stays and tighten the fixing bolt securely.

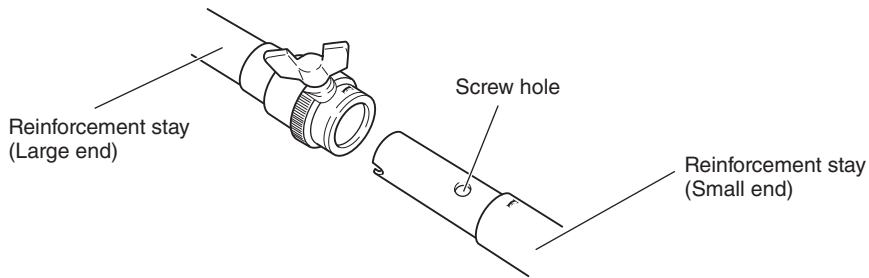

- 1-3 Connect the reinforcement stay to the large end leg. Insert the "E" marked end of the reinforcement stay (with its slant shaft facing down) into the joint (marked with "E") on the large end leg until it stops, then tighten the fixing bolt securely. In the same manner, connect the reinforcement stay to the small end leg. (There is no marking on the small end joint.)

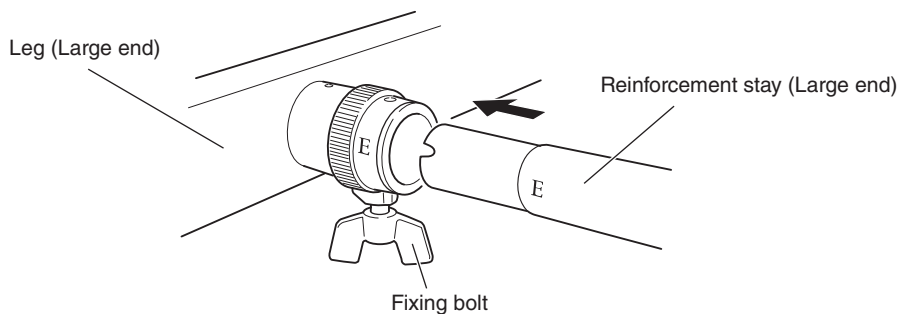

- 1-4 After making sure that both legs are perpendicular to the floor, fit the end of each slant shaft to the wing nut located in the lower part of each leg and tighten it securely.
- * Make sure that the slant shaft is securely fitted.

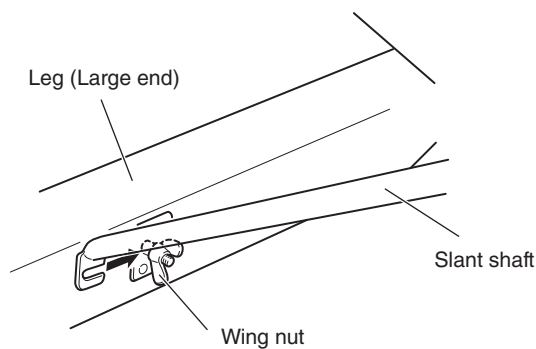

2 Insert the rails (2) and (3) into the end frames of the legs.

2-1 First, insert rail (2).

A "B" mark is printed on the big end face of the rail (2) and the grooved section of the end frame of the large end leg.

* Do not insert one side of the rail fully at first, but push both sides into the grooves alternately little by little until both sides are fully inserted.

Next, in the same manner, insert rail (3) securely.

A "C" mark is printed on the large end face of rail (3) and the grooved section of the end frame of the large end leg.

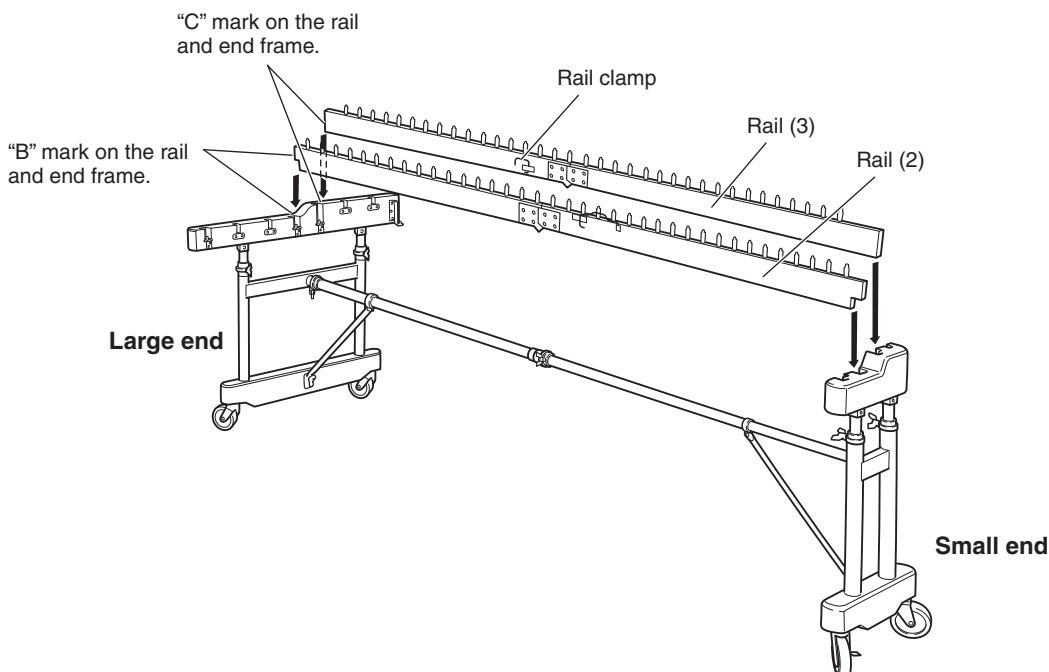

2-2 Engage the short rail clamp located at the center of rail (3) with rail (2).

* Release the clamp from its holder, lift and move it to rail (2) and push it down fully.

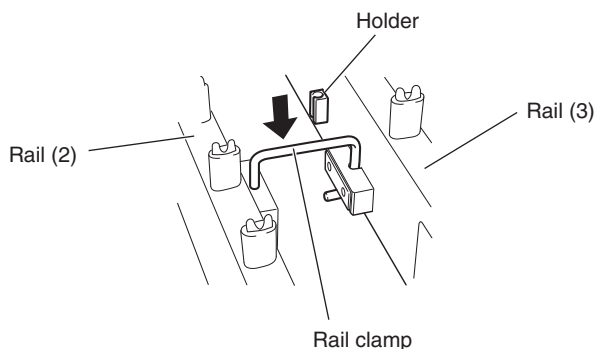

3 Attach the resonators.

3-1 Unbend the resonators, apply a hook and then tighten the wing nut securely. When assembling the resonator pipes, make sure that the washer is positioned on the outer side of the hook as shown in the illustration below.

- NOTICE**
- When assembling the resonators, be careful not to damage them.
 - Positioning the washer on the inner side of the hook can result in noise while playing.

* All of the natural tone resonators are closed at the bottom.

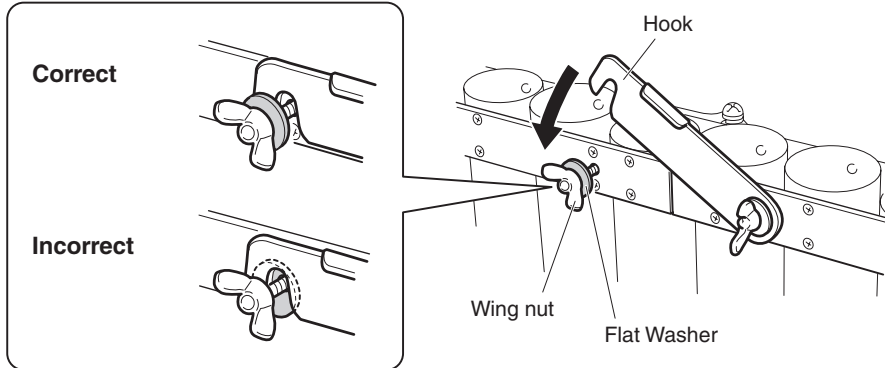

3-2 Insert the resonators into the resonator holders on the end frames in the same way as you did for the rails.

- NOTICE**
- Be sure not to confuse the natural tone resonators and accidental tone resonators.
 - Take care not to bump the resonators against the legs, etc.

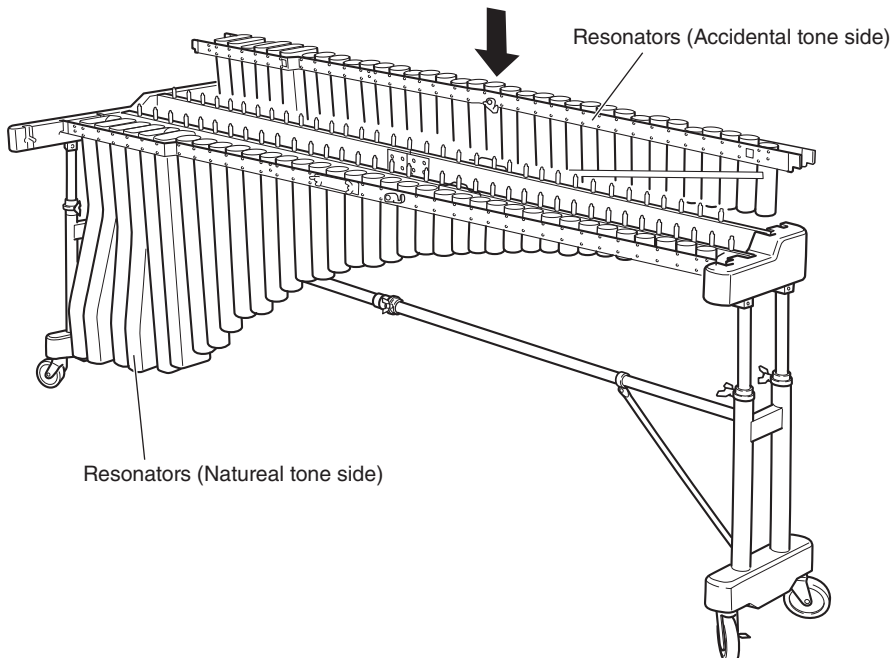

4 Insert rails (1) and (4) into the end frames of the legs.

- 4-1 Insert the outer rails (1) and (4) in the same manner as the inner rails (2) and (3). An "A" mark is printed on the large end face of rail (1) and the grooved section of the end frame of the large end leg, and a "D" mark for rail (4).

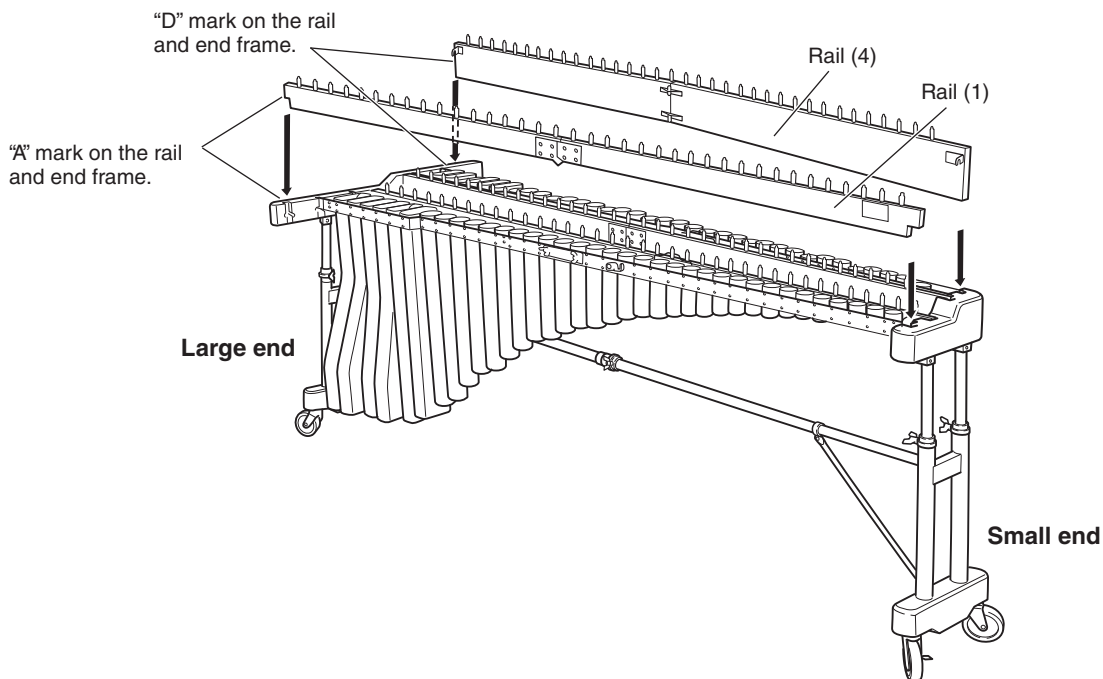

- 4-2 Engage the rail clamps on rail (2) and rail (3) with rail (1) and rail (4) respectively.

YM-5104A YM-5100A Only

- 4-3 Secure the resonators by fitting their hooks to the rail clamps engaged in Step 4-2.
- * Hooks are provided in two locations on both the natural tone side and the accidental tone side.
 - * Make sure that each hook is securely fitted.

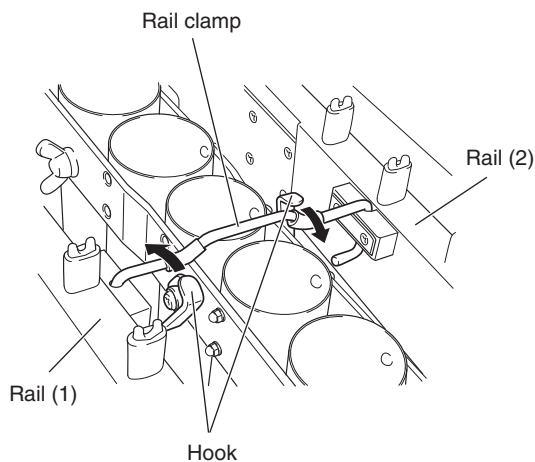

5 Set the tone bars.**5-1 Set the natural tone bars first.**

With one person holding the suspension cords on the bass side and the other person holding the suspension cords on the treble side securely with both hands, gently place the tone bars on the rails. Align each tone bar individually and hook its cord onto the corresponding post. After confirming that the cord is secured to every post, fix the tone bars by pulling the right and left cords forward from the large end side and hooking the two springs to each other.

NOTICE • When setting the tone bars, be careful not to damage them.

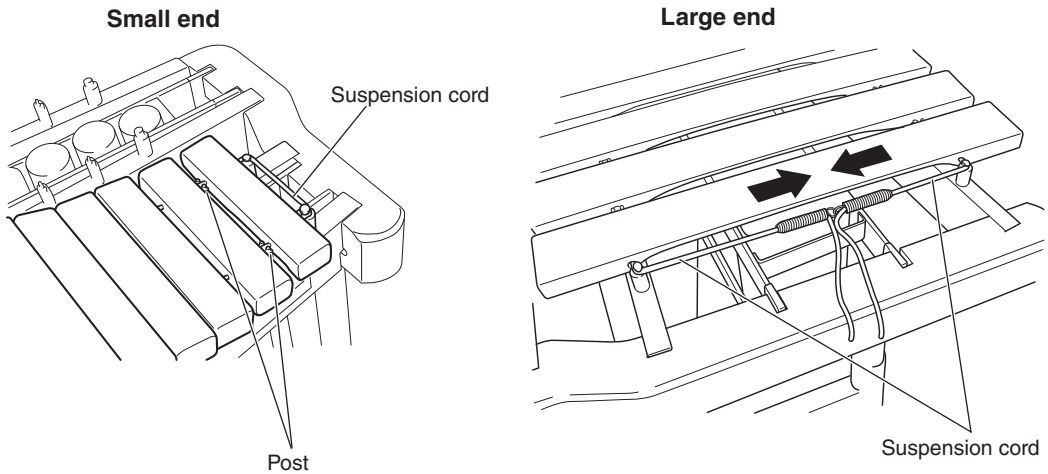
**YM-5104A YM-5100A YM-4900A Only**

5-2 Resonators F#²², G²³, G#²⁴, A²⁵ and A#²⁶ each have a resonance regulator. While tapping each tone bar, move the resonance regulator to find the position where the best resonance is obtained and affix it there.

NOTICE • When affixing the resonance regulator, check to ensure that it is not installed on a slant.

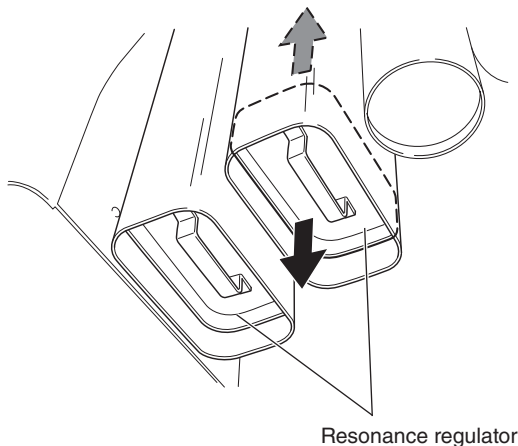

YM-4600A Only

5-2 Since the YM-4600A does not feature a resonance regulator, insert the resonators into the resonator holders as shown below.

* The resonators are factory adjusted so that the optimum resonance level is obtained at 23°C (73.4°F). If desirable resonance is not available due to the temperature being higher or lower than 23°C (73.4°F), adjust the setting of the resonators. Move the resonators to fit into shorter grooves when the temperature is higher and into longer grooves when the temperature is lower.

Temperature	Grooves to use
Higher	Short groove ("A" in the figure right)
Around 23°C (73.4°F)	Center groove ("B")
Lower	Long groove ("C")

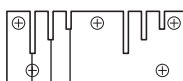

A : For a higher temperature
 B : For a temperature around 23°C (73.4°F)
 C : For a lower temperature

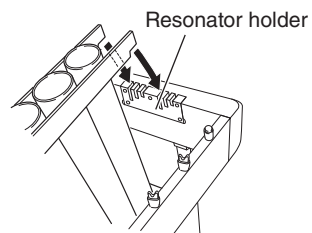

6 Adjust the height of the tone bars.



- When adjusting the tone bar height, be sure to have two people supporting the frame, one at each end using both hands.
- Do not place your feet under the resonators. Otherwise, your feet might get caught.

While supporting the frame end of the leg by hand, loosen the fixing bolt of the slide guide on both the large end and small end sides.

Adjust the height to the desired level and tighten the fixing bolts securely.

When adjusting the height, use the lines on the slide guide for reference and make the tone bars in parallel with the floor surface.

Upon completion of assembly, check to make sure that each bolt is tightened securely.

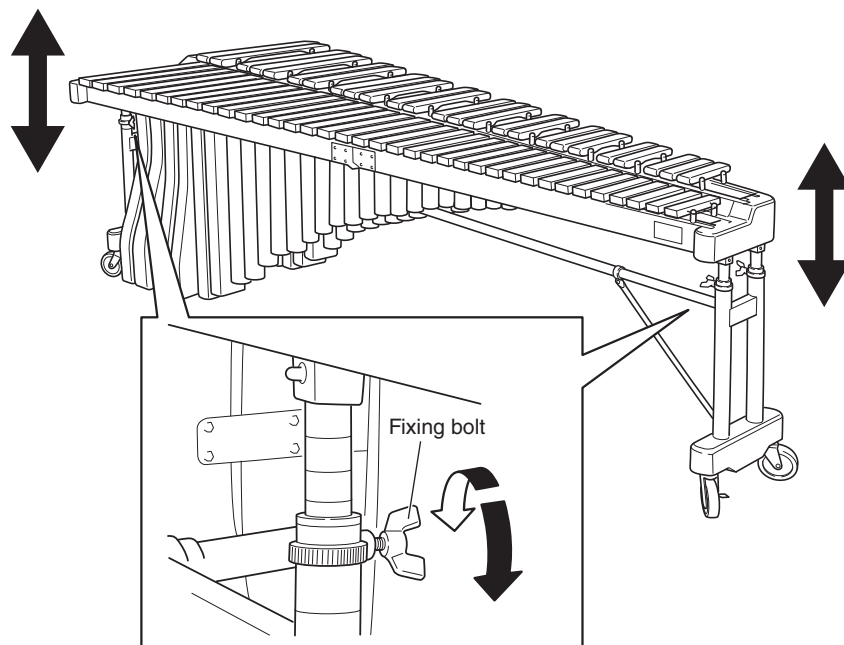

SPECIFICATIONS/SCALE RANGE

■ YM-5104A

- **Range:** C16 – G83 (5-1/2 octave)
- **Bars:** Rosewood
- **Bar sizes:**
72 – 41 mm (2.8" – 1.6") wide
24 – 20 mm (0.94" – 0.79") thick
- **Resonator:** Helmholtz, Elliptic low sound resonator
- **Height Adjustment:**
Gas spring system
15 cm (86 – 101 cm)
5.9" (33.9" – 39.8")
- **Dimensions (W x D):** 281 x 103 cm (110.6" x 40.6")
- **Weight:** 99 kg (218 lbs 4 oz)

■ YM-5100A

- **Range:** C16 – G76 (5 octave)
- **Bars:** Rosewood
- **Bar sizes:**
72 – 41 mm (2.8" – 1.6") wide
24 – 20 mm (0.94" – 0.79") thick
- **Resonator:** Helmholtz, Elliptic low sound resonator
- **Height Adjustment:**
Gas spring system
15 cm (86 – 101 cm)
5.9" (33.9" – 39.8")
- **Dimensions (W x D):** 261 x 103 cm (102.8" x 40.6")
- **Weight:** 96 kg (211 lbs 10 oz)

■ YM-4900A

- **Range:** F21 – C76 (4-1/2 octave)
- **Bars:** Rosewood
- **Bar sizes:**
65 – 41 mm (2.5" – 1.6") wide
24 – 20 mm (0.94" – 0.79") thick
- **Resonator:** Helmholtz, Elliptic low sound resonator
- **Height Adjustment:**
Gas spring system
15 cm (86 – 101 cm)
5.9" (33.9" – 39.8")
- **Dimensions (W x D):** 235 x 96 cm (92.5" x 37.8")
- **Weight:** 78 kg (171 lbs 15 oz)

■ YM-4600A

- **Range:** A25 – C76 (4-1/3 octave)
- **Bars:** Rosewood
- **Bar sizes:**
65 – 41 mm (2.5" – 1.6") wide
24 – 20 mm (0.94" – 0.79") thick
- **Resonator:** Circle resonator
- **Height Adjustment:**
Gas spring system
15 cm (86 – 101 cm)
5.9" (33.9" – 39.8")
- **Dimensions (W x D):** 219 x 91 cm (86.2" x 35.8")
- **Weight:** 68 kg (149 lbs 14 oz)

● SCALE RANGE

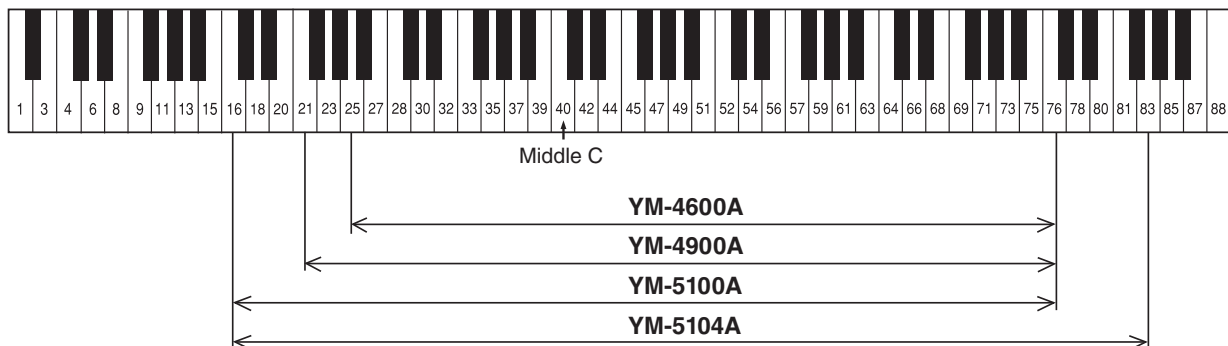

* The contents of this manual apply to the latest specifications as of the publishing date. To obtain the latest manual, access the Yamaha website then download the manual file.
Since specifications, equipment or separately sold accessories may not be the same in every locale, please check with your Yamaha dealer.

