

MUSIC PRODUCTION SYNTHESIZER

MOX6**MOX8**

Data List

Table of Contents

Voice List	2
Drum Voice List	11
Drum Voice Name List	11
Drum Kit Assign List	12
Waveform List	29
Performance List	34
Master Assign List	36
Arpeggio Type List	37
Effect Type List	78
Effect Parameter List	79
Effect Preset List	87
Effect Data Assign Table	89
Mixing Template List	97
Remote Control Assignments	98
Control List	99
MIDI Data Format	100
MIDI Data Table	104
MIDI Implementation Chart	127

Voice List

PRE1 (MSB=63, LSB=0)

Number		Voice Name	Category		Element
			Main	Sub	
1	A01	Full Concert Grand	Piano	APno	2
2	A02	Rock Grand Piano	Piano	Modrn	2
3	A03	Mellow Grand Piano	Piano	APno	2
4	A04	Glasgow	Piano	APno	4
5	A05	Romantic Piano	Piano	APno	2
6	A06	Aggressive Grand	Piano	Modrn	3
7	A07	Tacky	Piano	Modrn	2
8	A08	House Piano	Piano	Modrn	3
9	A09	Old and Squashed	Piano	Vintg	1
10	A10	Ballad Key	Piano	Layer	3
11	A11	80s Layer	Piano	Layer	4
12	A12	Ballad Stack	Piano	Layer	4
13	A13	Piano Back	Piano	Layer	4
14	A14	Piano & Strings	Piano	Layer	4
15	A15	Piano & Ooh Choir	Piano	Layer	4
16	A16	Monaural Grand MW	Piano	APno	1
17	B01	Old Blues	Piano	Vintg	2
18	B02	1968	Piano	Vintg	2
19	B03	CP 1979	Piano	Vintg	1
20	B04	CP70 Chorus	Piano	Vintg	1
21	B05	Journey	Piano	Vintg	1
22	B06	Vintage74	Keys	EP	1
23	B07	R&B Soft	Keys	EP	1
24	B08	Early 70's	Keys	EP	2
25	B09	Soft Case	Keys	EP	1
26	B10	Crunchy Comp	Keys	EP	1
27	B11	Vintage Case	Keys	EP	1
28	B12	Hard Vintage	Keys	EP	1
29	B13	Sweetness MW+AS2	Keys	EP	1
30	B14	Phaser Vintage	Keys	EP	1
31	B15	Vintage Phase	Keys	EP	1
32	B16	Early Fusion	Keys	EP	2
33	C01	Neo Soul MW+AS1	Keys	EP	1
34	C02	1983 MW+AS1	Keys	EP	2
35	C03	Contempo	Keys	EP	1
36	C04	Clicky Dyno MW+AS2	Keys	EP	1
37	C05	Dyno Straight MW+AS2	Keys	EP	2
38	C06	Dyno Chorus MW+AS2	Keys	EP	1
39	C07	80s Boosted	Keys	EP	2
40	C08	Chorus Hard	Keys	EP	1
41	C09	Max Tine	Keys	EP	3
42	C10	Bell Chorus	Keys	FM	2
43	C11	Drive EP AS1	Keys	EP	1
44	C12	Vinyl EP AS1	Keys	EP	2
45	C13	Natural Wurli	Keys	EP	2
46	C14	Wurli EP Bright	Keys	EP	1
47	C15	Wurli Distortion AS1	Keys	EP	2
48	C16	Phaze Wurli	Keys	EP	1
49	D01	DX Legend	Keys	FM	2
50	D02	Bell DX	Keys	FM	3
51	D03	DX Woody	Keys	FM	2
52	D04	Full Tine	Keys	FM	2
53	D05	DX Mellow	Keys	FM	2
54	D06	DX Crisp	Keys	FM	2
55	D07	DX Celesta EP	Keys	FM	2
56	D08	DX Pluck EP	Keys	FM	2
57	D09	DX-7 II AS1	Keys	FM	3
58	D10	GS Tines AF1&2	Keys	FM	2
59	D11	Galaxy DX	Keys	FM	4
60	D12	TX816 Bell Piano	Keys	FM	4
61	D13	Marimba DX	Keys	FM	4
62	D14	DX5-Zero	Keys	FM	4
63	D15	Hybrid EP	Keys	EP	3
64	D16	Mixed Up	Keys	EP	3

Number		Voice Name	Category		Element
			Main	Sub	
65	E01	Dyno Wurli	Keys	EP	2
66	E02	Analog Piano	Keys	Synth	2
67	E03	AhrAml	Keys	Synth	2
68	E04	Electro Piano	Keys	EP	2
69	E05	Transistor Piano	Keys	Synth	2
70	E06	EP Pad	Keys	EP	3
71	E07	DX Pad	Keys	EP	4
72	E08	Dyno Choir	Keys	EP	3
73	E09	Vintage Clavi	Keys	Clavi	2
74	E10	Super Clavi	Keys	Clavi	1
75	E11	Stereo Clavi	Keys	Clavi	2
76	E12	Hollow Clavi	Keys	Clavi	1
77	E13	Nu Phasing	Keys	Clavi	2
78	E14	Touch Clavi	Keys	Clavi	3
79	E15	Pedal Wah Clavi FC2	Keys	Clavi	3
80	E16	Pulse Clavi	Keys	Clavi	1
81	F01	Guitarsichord	Keys	Clavi	3
82	F02	Hipsichord	Keys	Clavi	3
83	F03	16 + 8 + 5&1/3	Organ	TnWhl	4
84	F04	Jazz 2nd Perc + C3	Organ	TnWhl	5
85	F05	First 3 w/Perc	Organ	TnWhl	4
86	F06	Slow Jam	Organ	TnWhl	3
87	F07	Cool Cat	Organ	TnWhl	4
88	F08	Jazzy 1	Organ	TnWhl	4
89	F09	Jazzy 2	Organ	TnWhl	4
90	F10	Jazzy Chorus	Organ	TnWhl	4
91	F11	On Road AS1	Organ	TnWhl	4
92	F12	Progressy	Organ	TnWhl	4
93	F13	Rocky AS2	Organ	TnWhl	4
94	F14	Crunchy AS2	Organ	TnWhl	4
95	F15	1972 AS1	Organ	Combo	8
96	F16	Glassy AF1	Organ	TnWhl	4
97	G01	Clean	Organ	TnWhl	2
98	G02	All Bars Perc AF1&2	Organ	TnWhl	8
99	G03	Rotor Vibrato	Organ	TnWhl	8
100	G04	Vib Chorus AF1	Organ	TnWhl	1
101	G05	Soulemn	Organ	TnWhl	3
102	G06	Mellow AS2	Organ	TnWhl	2
103	G07	Fully	Organ	TnWhl	4
104	G08	FullDraw/CVibrato	Organ	TnWhl	2
105	G09	Even Out	Organ	TnWhl	4
106	G10	Harmonic Hole	Organ	TnWhl	5
107	G11	A Few Wheels	Organ	TnWhl	4
108	G12	Left Manual	Organ	TnWhl	4
109	G13	Draw Control	Organ	TnWhl	4
110	G14	Stop Rotar	Organ	TnWhl	5
111	G15	Clean Noise	Organ	TnWhl	3
112	G16	Walking Bass	Organ	TnWhl	3
113	H01	Greasy	Organ	TnWhl	4
114	H02	Swishie	Organ	TnWhl	3
115	H03	Solo Percussion AF2	Organ	TnWhl	2
116	H04	PercussionVibratoAF2	Organ	TnWhl	2
117	H05	Tiny Combo Bars 1	Organ	Combo	4
118	H06	Tiny Combo Bars 2	Organ	Combo	3
119	H07	Panther	Organ	Combo	3
120	H08	1967 Keys	Organ	Combo	1
121	H09	YD-45C	Organ	Combo	3
122	H10	Diamond Head	Organ	Synth	2
123	H11	Early Bird	Organ	TnWhl	4
124	H12	Moet	Organ	Synth	2
125	H13	Bollinger	Organ	Synth	2
126	H14	Vinyl Organ	Organ	Synth	2
127	H15	Alternator	Organ	TnWhl	3
128	H16	Flying Rhythm Bars	Organ	Synth	6

PRE2 (MSB=63, LSB=1)

Number		Voice Name	Category		Element
			Main	Sub	
1	A01	Roundabout	Organ	Arp	1
2	A02	Tradi	Organ	TnWhl	4
3	A03	Petit	Organ	TnWhl	1
4	A04	Fluty	Organ	TnWhl	1
5	A05	Fluty Pipe	Organ	Pipe	3
6	A06	St. Peter	Organ	Pipe	1
7	A07	St. Paul AF1&2	Organ	Pipe	3
8	A08	Impromptu	Organ	Pipe	4
9	A09	Mixture	Organ	Pipe	3
10	A10	Reed Split	Organ	Pipe	4
11	A11	Medieval MW	Organ	Pipe	4
12	A12	Breath Pipe	Organ	Pipe	4
13	A13	Reedy Pipe	Organ	Pipe	4
14	A14	Sunday	Organ	Pipe	4
15	A15	Accordions AF1&2	Organ	Pipe	1
16	A16	Soft Marimba	CPerc	Malet	1
17	B01	Vibes Bow MW	CPerc	Malet	3
18	B02	Twinkle	CPerc	Bell	4
19	B03	Stick Bell	CPerc	Bell	3
20	B04	Ice Bells	CPerc	Bell	4
21	B05	Bell Ice	CPerc	Bell	3
22	B06	Stack Bell	CPerc	SynBl	4
23	B07	J-Pop	CPerc	Bell	3
24	B08	Chorus Bell	CPerc	Bell	2
25	B09	Handbell	CPerc	Bell	2
26	B10	Bell Chiff	CPerc	SynBl	2
27	B11	Sako Bell	CPerc	SynBl	2
28	B12	Nice Bell	CPerc	SynBl	4
29	B13	Noisy Bell	CPerc	SynBl	3
30	B14	Pop Bells & Pad MW	CPerc	Bell	4
31	B15	Going To Heaven	CPerc	Arp	3
32	B16	Digibox	CPerc	SynBl	3
33	C01	Nibelungen	CPerc	Bell	2
34	C02	Wood Bell	CPerc	Bell	4
35	C03	Marimbell	CPerc	SynBl	4
36	C04	Synth Steel Drum	CPerc	PDrum	3
37	C05	Gamelan	CPerc	Bell	2
38	C06	Ethnic Dream	CPerc	Malet	2
39	C07	Mystic Bowl	CPerc	Bell	2
40	C08	Mbira	Ethnic	Pluk	4
41	C09	Glass Mbira	CPerc	PDrum	4
42	C10	Island Bell	CPerc	SynBl	3
43	C11	Tibetan	CPerc	Bell	3
44	C12	Rimba Bells	CPerc	SynBl	3
45	C13	Lost in Asia	CPerc	Bell	4
46	C14	Coconuts Random	CPerc	Arp	1
47	C15	Kodo	CPerc	PDrum	1
48	C16	Timpani/Bell/Glocken	CPerc	Bell	2
49	D01	Orc Percussion	CPerc	Bell	4
50	D02	Classical AF1&2	Guitar	A.Gtr	2
51	D03	High Tension AF1&2	Guitar	A.Gtr	2
52	D04	Sao Paulo	Guitar	A.Gtr	2
53	D05	Barcelona	Guitar	A.Gtr	4
54	D06	Nylon Slide Vel	Guitar	A.Gtr	4
55	D07	Nylon Harmonics Vel	Guitar	A.Gtr	4
56	D08	Classical 12 Strings	Guitar	A.Gtr	4
57	D09	Hip-Hop Nylon Guitar	Guitar	A.Gtr	2
58	D10	Steel String AF1&2	Guitar	A.Gtr	2
59	D11	Old Strings AF1&2	Guitar	A.Gtr	2
60	D12	Steel Slide Vel	Guitar	A.Gtr	4
61	D13	Mute & Slide Vel	Guitar	A.Gtr	2
62	D14	Steel Harmonics Vel	Guitar	A.Gtr	4
63	D15	Hip-Hop Steel Guitar	Guitar	A.Gtr	2
64	D16	Hi Strings	Guitar	A.Gtr	2

Number		Voice Name	Category		Element
			Main	Sub	
65	E01	Two Acoustics	Guitar	A.Gtr	4
66	E02	2 Steel Strings	Guitar	A.Gtr	4
67	E03	Big 12 Strings	Guitar	A.Gtr	4
68	E04	Airy 12 AF1&2	Guitar	A.Gtr	4
69	E05	Wide 12 strings AF1	Guitar	A.Gtr	4
70	E06	12Strings Mono	Guitar	A.Gtr	2
71	E07	Clean EI & Ac 1	Guitar	E.Cln	3
72	E08	Clean EI & Ac 2	Guitar	E.Cln	3
73	E09	Clean EI & Ac 3	Guitar	E.Cln	3
74	E10	Strange 12	Guitar	E.Cln	4
75	E11	Jazzy Pick	Guitar	E.Cln	2
76	E12	Melodic Jazz	Guitar	E.Cln	2
77	E13	Fat Oil Jazz AF1&2	Guitar	E.Cln	1
78	E14	Touch Wah AF1	Guitar	E.Cln	1
79	E15	Baby AF1	Guitar	E.Cln	3
80	E16	Good Night	Guitar	E.Cln	1
81	F01	Dynamic Clean AF1&2	Guitar	E.Cln	1
82	F02	Single Coil Chorus	Guitar	E.Cln	2
83	F03	Distant	Guitar	E.Cln	4
84	F04	Some Hair	Guitar	E.Dst	3
85	F05	Clean Slide Vel	Guitar	E.Cln	2
86	F06	Hit It Hard AS2	Guitar	E.Cln	2
87	F07	Paddy Clean	Guitar	E.Cln	2
88	F08	Bluesy Clean Legato	Guitar	E.Cln	2
89	F09	Dual Coil '65	Guitar	E.Dst	2
90	F10	Dual Coil Amp AS1	Guitar	E.Cln	1
91	F11	Roto Guitar MW	Guitar	E.Cln	2
92	F12	Dual Coil Slide Vel	Guitar	E.Cln	2
93	F13	Dual Coil Slap Vel	Guitar	E.Cln	2
94	F14	Dual Coil 80s Clean	Guitar	E.Cln	2
95	F15	Dual Coil Rotary	Guitar	E.Cln	2
96	F16	Electric 12Strings	Guitar	E.Cln	3
97	G01	Rotator AF1&2	Guitar	E.Dst	2
98	G02	Middy Tremolo	Guitar	E.Dst	3
99	G03	Retro Flanger	Guitar	E.Cln	2
100	G04	Vintage Strum	Guitar	E.Cln	3
101	G05	Spanky	Guitar	E.Dst	2
102	G06	Rockabilly	Guitar	E.Dst	2
103	G07	2 Electrics AF1&2	Guitar	E.Cln	2
104	G08	Light Blues AF1&2	Guitar	E.Dst	1
105	G09	Dual Coil Semi Clean	Guitar	E.Cln	1
106	G10	Chorus Dist AF1&2	Guitar	E.Dst	2
107	G11	Tex Boogie	Guitar	E.Dst	3
108	G12	59 Combo AF1&2	Guitar	E.Dst	2
109	G13	Alternative Rocker	Guitar	E.Dst	2
110	G14	Overdrive Mute&Harmo	Guitar	E.Dst	1
111	G15	Crunched Up 376	Guitar	E.Dst	3
112	G16	Dynamic Amp AS1	Guitar	E.Dst	3
113	H01	Chuggin' Guitar	Guitar	E.Dst	2
114	H02	Chugga	Guitar	E.Dst	1
115	H03	Small Amp AS1	Guitar	E.Dst	2
116	H04	Metal Mute AS2	Guitar	E.Dst	2
117	H05	DistortionMute&Harmo	Guitar	E.Dst	1
118	H06	Cool Drive AS1	Guitar	E.Dst	3
119	H07	Hard Drive AS1&2	Guitar	E.Dst	4
120	H08	Hard Ramp AS1&2	Guitar	E.Dst	3
121	H09	Heavy Drive	Guitar	E.Dst	2
122	H10	No.1 GTR AS1&2	Guitar	E.Dst	2
123	H11	Snake Finger	Guitar	E.Dst	2
124	H12	Dual Coil Blue Lead	Guitar	E.Dst	2
125	H13	Over The Top	Guitar	E.Dst	2
126	H14	Voodooman	Guitar	E.Dst	2
127	H15	Killer Whammy	Guitar	E.Dst	3
128	H16	Latin Lover	Guitar	E.Dst	1

PRE3 (MSB=63, LSB=2)

Number	Voice Name	Category		Element	
		Main	Sub		
1	A01	Oct FuzzPedalWah FC2	Guitar	E.Dst	3
2	A02	DualCoilLeadWah FC2	Guitar	E.Dst	2
3	A03	DualCoilHarmonicsVel	Guitar	E.Dst	3
4	A04	Crunchy Guitar	Guitar	E.Dst	3
5	A05	Beater AS2	Guitar	E.Dst	2
6	A06	HIP Mute	Guitar	E.Cln	2
7	A07	Pedal Steel	Guitar	E.Cln	2
8	A08	DualCoil80sCleanMute	Guitar	E.Cln	1
9	A09	Mid Drive (2handGtr)	Guitar	E.Dst	3
10	A10	HardRocker(2handGtr)	Guitar	E.Dst	3
11	A11	ToughTube (2handGtr)	Guitar	E.Dst	1
12	A12	DriveWah (2handGtr)	Guitar	E.Dst	4
13	A13	Resonator Guitar	Guitar	A.Gtr	4
14	A14	Velo Growl	Bass	ABass	2
15	A15	GrooveAcoustic AF1&2	Bass	ABass	1
16	A16	Upright	Bass	ABass	2
17	B01	Prec Flat Wound	Bass	EBass	2
18	B02	Round Wound	Bass	EBass	2
19	B03	Active P	Bass	EBass	2
20	B04	Mid Range Finger	Bass	EBass	2
21	B05	Active TRB	Bass	EBass	1
22	B06	Passive BB AF1&2	Bass	EBass	1
23	B07	Vintage JB AF1&2	Bass	EBass	1
24	B08	StraightFinger AF1&2	Bass	EBass	1
25	B09	JB Flat Wound AF1&2	Bass	EBass	1
26	B10	Finger PBs AF1	Bass	EBass	1
27	B11	Prec Amped AF1	Bass	EBass	2
28	B12	Finger Bass Amp AF1	Bass	EBass	2
29	B13	Fret Buzzy	Bass	EBass	2
30	B14	Small Cabinet	Bass	EBass	1
31	B15	Simple Pick	Bass	EBass	1
32	B16	Pick Open	Bass	EBass	3
33	C01	Pick Mute	Bass	EBass	2
34	C02	Pick Pull	Bass	EBass	2
35	C03	Straight Pick AF1&2	Bass	EBass	2
36	C04	Velo Bass	Bass	EBass	1
37	C05	Slap Switch	Bass	EBass	2
38	C06	Fretless Dry	Bass	EBass	2
39	C07	Fretless Solo	Bass	EBass	2
40	C08	PBassFingerDist AF1	Bass	EBass	2
41	C09	Fuzz Bass AF1AS1	Bass	EBass	3
42	C10	Gnarly Bass	Bass	EBass	1
43	C11	BaCement	Bass	EBass	1
44	C12	Dist Tama Bass	Bass	EBass	3
45	C13	5th Fuzz Bass	Bass	EBass	3
46	C14	Chili Bass	Bass	EBass	3
47	C15	Big Cabinet	Bass	EBass	2
48	C16	Hybrid Bass 1	Bass	EBass	3
49	D01	Hybrid Bass 2	Bass	EBass	3
50	D02	3 VCOs	Bass	SynBs	4
51	D03	Brain Bass AF1&2	Bass	SynBs	3
52	D04	Lo Boy AF1&2 AS1&2	Bass	SynBs	3
53	D05	Dark Bass	Bass	SynBs	1
54	D06	RnBass RB	Bass	SynBs	2
55	D07	Fundamental	Bass	SynBs	2
56	D08	Fat Sine Resonance	Bass	SynBs	3
57	D09	Moon Bass	Bass	SynBs	1
58	D10	More Fatty	Bass	SynBs	4
59	D11	Chill Out Bass AF1	Bass	SynBs	1
60	D12	Growler	Bass	SynBs	2
61	D13	Smacked	Bass	SynBs	2
62	D14	boooooooooooooom	Bass	SynBs	2
63	D15	Biting	Bass	SynBs	2
64	D16	Boogie A LegatoAF1RB	Bass	SynBs	3

Number	Voice Name	Category		Element	
		Main	Sub		
65	E01	Uni Punch	Bass	SynBs	2
66	E02	Noise Bass	Bass	SynBs	1
67	E03	Single Oscillator	Bass	SynBs	1
68	E04	Unison	Bass	SynBs	3
69	E05	Long Spit AF2	Bass	SynBs	2
70	E06	Big Bass	Bass	SynBs	3
71	E07	Bass&Comp!	Bass	SynBs	4
72	E08	Rave Blade	Bass	SynBs	2
73	E09	Plastic Bass	Bass	SynBs	3
74	E10	Funky Resonance RB	Bass	SynBs	3
75	E11	Phat Three	Bass	SynBs	3
76	E12	Needle Bass	Bass	SynBs	3
77	E13	Acidd	Bass	SynBs	3
78	E14	Boom Bass AF1	Bass	SynBs	2
79	E15	West Coast	Bass	SynBs	2
80	E16	Wazzo	Bass	SynBs	2
81	F01	Fast PWM Bass	Bass	SynBs	2
82	F02	Bass Pedal	Bass	SynBs	2
83	F03	Oxide	Bass	SynBs	2
84	F04	Bowngo	Bass	SynBs	1
85	F05	Wide Synth Bass	Bass	SynBs	2
86	F06	Dry Synth Bass	Bass	SynBs	1
87	F07	Kick Bass Legato	Bass	SynBs	3
88	F08	Keep Dancin' AS2	Bass	SynBs	3
89	F09	Velo Master	Bass	SynBs	1
90	F10	Wah Bass	Bass	SynBs	2
91	F11	Pulse Step AF1	Bass	SynBs	2
92	F12	Phat Step AS1&2	Bass	SynBs	2
93	F13	Octave Analog	Bass	SynBs	2
94	F14	Sync Bass	Bass	SynBs	1
95	F15	Sync Big	Bass	SynBs	2
96	F16	Puncher AS1	Bass	SynBs	2
97	G01	Dark Comp AF1&2	Bass	SynBs	2
98	G02	Simple Bass AS2	Bass	SynBs	2
99	G03	Fat Sine	Bass	SynBs	4
100	G04	Kompressor	Bass	SynBs	3
101	G05	Dark Uni	Bass	SynBs	1
102	G06	Fight Bass	Bass	SynBs	3
103	G07	Byon Bass	Bass	SynBs	5
104	G08	One Voice	Bass	SynBs	1
105	G09	Pro-Attack AF1	Bass	SynBs	2
106	G10	Bobby Bass	Bass	SynBs	2
107	G11	Trance Bass AS2	Bass	SynBs	2
108	G12	Short Sequence Bass	Bass	SynBs	2
109	G13	Lately	Bass	SynBs	2
110	G14	Faaat Pulse	Bass	SynBs	3
111	G15	Short PWM Bass	Bass	SynBs	2
112	G16	Hyper Velocity AF1	Bass	SynBs	2
113	H01	Deep Point	Bass	SynBs	2
114	H02	Pulse Stop	Bass	SynBs	1
115	H03	Oh Bee Bass	Bass	SynBs	2
116	H04	Booming Bass	Bass	SynBs	3
117	H05	Army Bass	Bass	SynBs	2
118	H06	Punchy Drone RB	Bass	SynBs	4
119	H07	Dee Tune	Bass	SynBs	2
120	H08	Chorus Pulse	Bass	SynBs	1
121	H09	Sweeper	Bass	SynBs	2
122	H10	Old House Organ	Bass	SynBs	4
123	H11	Data Run	Bass	Arp	1
124	H12	Sharp 3o3	Bass	Arp	1
125	H13	Short 3o3 Saw	Bass	Arp	1
126	H14	Acid Fun AS1	SynLd	Arp	1
127	H15	Compu Bass	Bass	Arp	1
128	H16	Squeaker Bass	Bass	Arp	1

PRE4 (MSB=63, LSB=3)

Number		Voice Name	Category		Element
			Main	Sub	
1	A01	Violin Solo 1	String	Solo	3
2	A02	Violin Solo 2 AF1	String	Solo	1
3	A03	Viola Solo 1	String	Solo	3
4	A04	Viola Solo 2 AF1	String	Solo	2
5	A05	Cello Solo	String	Solo	3
6	A06	Cello Duo AF1	String	Solo	2
7	A07	Contrabass Solo	String	Solo	3
8	A08	Contrabass Solo2 AF1	String	Solo	2
9	A09	Quartet	String	Ensem	4
10	A10	Small Section	String	Ensem	3
11	A11	Small Ensemble	String	Ensem	4
12	A12	Almighty	String	Ensem	4
13	A13	Medium Section	String	Ensem	4
14	A14	Medium Hall	String	Ensem	4
15	A15	Medium Large Section	String	Ensem	2
16	A16	Quick Bows	String	Ensem	4
17	B01	Aggressive AF1	String	Ensem	2
18	B02	Large Section	String	Ensem	4
19	B03	Octave Ensemble	String	Ensem	4
20	B04	Full Chamber	String	Ensem	4
21	B05	Stryngs	String	Ensem	4
22	B06	Dynamik Bow	String	Ensem	4
23	B07	Symphonic Pizzicato	String	Pizz	2
24	B08	Plucky Pizzicato	String	Pizz	2
25	B09	Octave Pizzes	String	Pizz	4
26	B10	Tremolo Strings 1	String	Ensem	4
27	B11	TremoloStrings Small	String	Ensem	4
28	B12	Spicato Large	String	Pizz	4
29	B13	Disco AF1	String	Pizz	4
30	B14	Ens Mix	String	Ensem	2
31	B15	Lush	String	Ensem	4
32	B16	Back Ground	String	Ensem	4
33	C01	Romantic	String	Ensem	4
34	C02	Warm Back	String	Ensem	3
35	C03	Stringy	String	Ensem	4
36	C04	Big Strings	String	Ensem	4
37	C05	PWM Strings	String	Synth	3
38	C06	Mourn Strings	String	Synth	4
39	C07	VP Soft	String	Synth	3
40	C08	PWM Simple	String	Synth	3
41	C09	Glassy Rezonant	String	Synth	4
42	C10	Superstrings	String	Synth	3
43	C11	Light Pad	String	Synth	4
44	C12	Noble Pad	String	Synth	2
45	C13	Warm Big	String	Ensem	4
46	C14	Sentimental	String	Synth	4
47	C15	Analog Sweep	String	Synth	4
48	C16	Phase Strings AS1	String	Synth	4
49	D01	Octave Strings	String	Synth	4
50	D02	JP Strings	String	Synth	2
51	D03	3Oscillators Vintage	String	Synth	3
52	D04	Silver Strings	String	Synth	2
53	D05	String Machine	String	Synth	3
54	D06	3 Octave Strings	String	Synth	4
55	D07	Trance Introduction	String	Synth	2
56	D08	Mystic Trance	String	Synth	4
57	D09	F.Horn + Strings	String	Ensem	4
58	D10	Wood Winds + Strings	String	Synth	4
59	D11	ElectricViolin AF1&2	String	Solo	1
60	D12	Tron Violin	String	Synth	4
61	D13	Tron Strings	String	Synth	3
62	D14	Tape Strings AS2	String	Synth	3
63	D15	Orchestronic	String	Synth	4
64	D16	Vinyltron	String	Synth	4

Number		Voice Name	Category		Element
			Main	Sub	
65	E01	Analog Strings	String	Synth	1
66	E02	Analog Ensemble	String	Ensem	3
67	E03	Pizz-o-matic	String	Arp	2
68	E04	Ambient Pizza	String	Arp	4
69	E05	Beauty Harp	String	Pizz	1
70	E06	Stereo Harp	String	Pizz	3
71	E07	Trumpet 1 AF1	Brass	Solo	2
72	E08	Tp Romantic Legato	Brass	Solo	2
73	E09	Classical Trumpet	Brass	Solo	1
74	E10	Baby Trumpet AF1	Brass	Solo	2
75	E11	Bright Trumpet AF1	Brass	Solo	2
76	E12	Tp Soft Jazz Legato	Brass	Solo	2
77	E13	Legend Mute AF1	Brass	Solo	3
78	E14	Jazzy Flugel AF1	Brass	Solo	2
79	E15	Trumpet Section	Brass	BrsEn	4
80	E16	Trombone 1 AF1	Brass	Solo	2
81	F01	Blown Bone Legato	Brass	Solo	1
82	F02	Bright Trombone AF1	Brass	Solo	2
83	F03	New Orleans Trombone	Brass	Solo	2
84	F04	French Horn AF1	Brass	Solo	1
85	F05	French Horn Solo	Brass	Solo	1
86	F06	BassTuba(Bb)	Brass	Solo	2
87	F07	Euphonium	Brass	Orche	2
88	F08	Bony Section	Brass	BrsEn	4
89	F09	French Horn Section	Brass	Orche	2
90	F10	F.Horn + Trombone	Brass	Orche	4
91	F11	F.Hrn + Trmbn + Trp	Brass	Orche	4
92	F12	Orchestra Brass	Brass	Orche	4
93	F13	Movie Horns	Brass	Orche	4
94	F14	Symphonic	Brass	Orche	4
95	F15	Smooth Brass	Brass	Orche	4
96	F16	SoftBrss mp-mf AF1&2	Brass	Orche	2
97	G01	Dynamic Brass AF1&2	Brass	Orche	2
98	G02	Accent mf-fall AF1&2	Brass	BrsEn	4
99	G03	Small Brass Section	Brass	BrsEn	2
100	G04	Medium Brass Section	Brass	BrsEn	4
101	G05	Lots O' Brass	Brass	BrsEn	4
102	G06	Bright Section	Brass	BrsEn	4
103	G07	Power Section	Brass	BrsEn	4
104	G08	Shiny Brass	Brass	BrsEn	4
105	G09	Big Brass AF1&2	Brass	BrsEn	4
106	G10	Sforzando AF1&2	Brass	BrsEn	4
107	G11	Soft Brass & Sax	Brass	BrsEn	4
108	G12	Big Band	Brass	BrsEn	4
109	G13	Sax Big Band	Brass	BrsEn	4
110	G14	Velo Falls	Brass	BrsEn	3
111	G15	Hybrid Section	Brass	Synth	3
112	G16	Hybrid Bright	Brass	Synth	3
113	H01	Hybrid Brass Swell	Brass	Synth	4
114	H02	T Brass	Brass	Synth	2
115	H03	Lo-fi AS1&2	Brass	BrsEn	1
116	H04	Quiet Brass	Brass	Synth	2
117	H05	Big Syn	Brass	Synth	2
118	H06	Thin	Brass	Synth	2
119	H07	XP Brass Stereo	Brass	Synth	2
120	H08	Simple Saw Brass	Brass	Synth	4
121	H09	Brassy	Brass	Synth	2
122	H10	Kustom	Brass	Synth	3
123	H11	After 1984	Brass	Synth	4
124	H12	Finale	Brass	Synth	2
125	H13	Huge CS80	Brass	Synth	2
126	H14	CS-90	Brass	Synth	2
127	H15	Ob Soft	Brass	Synth	4
128	H16	Ob Horns	Brass	Synth	2

PRE5 (MSB=63, LSB=4)

Number		Voice Name	Category		Element
			Main	Sub	
1	A01	Slow PWM Brass	Brass	Synth	2
2	A02	Soft 5th Brass	Brass	Synth	4
3	A03	Soprano Legato	SaxWW	Sax	2
4	A04	Soprano Soft AF1	SaxWW	Sax	2
5	A05	Alto Vib Legato	SaxWW	Sax	3
6	A06	Alto Legato	SaxWW	Sax	1
7	A07	Alto	SaxWW	Sax	1
8	A08	Tenor Dynamic AF1	SaxWW	Sax	3
9	A09	Tenor Soft Legato	SaxWW	Sax	3
10	A10	Velo Growl Legato	SaxWW	Sax	3
11	A11	Tenor Growl AF1	SaxWW	Sax	1
12	A12	Baritone	SaxWW	Sax	1
13	A13	Hip Bari	SaxWW	Sax	1
14	A14	Tenor Section	SaxWW	Sax	3
15	A15	Sax Octave Section	SaxWW	Sax	4
16	A16	Mixed Sax Section	SaxWW	Sax	4
17	B01	Flute Legato	SaxWW	Flute	3
18	B02	Sweet Flute AF1	SaxWW	Flute	2
19	B03	Wood Flute	SaxWW	Flute	2
20	B04	Oboe 1 AF1	SaxWW	RPipe	3
21	B05	Sweet Oboe Legato	SaxWW	RPipe	2
22	B06	Oboe Soft Legato	SaxWW	RPipe	2
23	B07	Clarinet 1 AF1	SaxWW	WWind	3
24	B08	JazzyClarinet Legato	SaxWW	RPipe	2
25	B09	Bassoon 1 AF1	SaxWW	RPipe	3
26	B10	Irish Pipe Legato	SaxWW	RPipe	1
27	B11	2 Flutes	SaxWW	Flute	3
28	B12	Flute & Clari	SaxWW	Flute	4
29	B13	2 Oboes & Bassoon	SaxWW	WWind	4
30	B14	WoodWind Quartet	SaxWW	WWind	8
31	B15	Gentle Harp	SaxWW	RPipe	1
32	B16	Woody Harp	SaxWW	RPipe	1
33	C01	Bluz Distort	SaxWW	RPipe	2
34	C02	Campfire	SaxWW	RPipe	2
35	C03	Tron Flute	SaxWW	Flute	3
36	C04	Flootz	SaxWW	Flute	2
37	C05	Huge Lead	SynLd	Analg	4
38	C06	Bleep Lead AF2	SynLd	Analg	2
39	C07	Detuned Vintage	SynLd	Analg	2
40	C08	Space Lead	SynLd	Analg	2
41	C09	Dual Square Lead	SynLd	Analg	2
42	C10	Vintage Sync	SynLd	Analg	2
43	C11	Dirty Hook	SynLd	Analg	4
44	C12	Nu Mini	SynLd	Analg	3
45	C13	ProgressiveRock Lead	SynLd	Analg	3
46	C14	Lucky	SynLd	Analg	2
47	C15	Opening	SynLd	Analg	2
48	C16	Rap Lead 1	SynLd	Analg	1
49	D01	Mini Soft	SynLd	Analg	2
50	D02	Feeling	SynLd	Analg	1
51	D03	Early Lead	SynLd	Analg	2
52	D04	Funky Pulse	SynLd	Digitl	1
53	D05	Mr. Finger	SynLd	Analg	2
54	D06	Singleline	SynLd	Analg	2
55	D07	Soft RnB	SynLd	Analg	1
56	D08	Wind Synth	SynLd	Analg	3
57	D09	Broken Sine RBAS1	SynLd	Analg	1
58	D10	Duck Lead	SynLd	Analg	1
59	D11	In da Night	SynLd	Analg	1
60	D12	Mayday MW	SynLd	Analg	1
61	D13	On D Line	SynLd	Analg	2
62	D14	Early Soloist	SynLd	Analg	1
63	D15	Heterodyne	SynLd	Analg	1
64	D16	Classic 5th	SynLd	Analg	3

Number		Voice Name	Category		Element
			Main	Sub	
65	E01	Vintage Saw	SynLd	Analg	3
66	E02	Mini Three	SynLd	Digitl	3
67	E03	Phat Dino	SynLd	Digitl	3
68	E04	Dynamic Mini	SynLd	Digitl	3
69	E05	PWM Lead	SynLd	Digitl	2
70	E06	Pulse Wound	SynLd	Digitl	1
71	E07	Think Sync	SynLd	Digitl	3
72	E08	Punch Lead	SynLd	Digitl	2
73	E09	Bright Saw	SynLd	Digitl	2
74	E10	Trojan	SynLd	Digitl	3
75	E11	Wood Panel	SynLd	Digitl	2
76	E12	Push Ahead	SynLd	Digitl	1
77	E13	Eight	SynLd	Digitl	4
78	E14	Sync Power	SynLd	Digitl	2
79	E15	Gliten Lead	SynLd	Digitl	4
80	E16	Big Drone	SynLd	Digitl	4
81	F01	Screameemy	SynLd	Digitl	2
82	F02	Flange Filter	SynLd	Digitl	2
83	F03	Sutra	SynLd	Digitl	3
84	F04	Free LFO	SynLd	Digitl	1
85	F05	Rap Lead 2	SynLd	Digitl	1
86	F06	Space Power Lead	SynLd	Digitl	2
87	F07	Nyquist	SynLd	Digitl	2
88	F08	Digimetal	SynLd	Digitl	1
89	F09	Saw destroy	SynLd	Digitl	3
90	F10	Vinalog saw	SynLd	Digitl	4
91	F11	Mady SQU	SynLd	Digitl	2
92	F12	Low Undulation	SynLd	Digitl	4
93	F13	Impact	SynLd	H Hop	3
94	F14	Talk Mod	SynLd	H Hop	2
95	F15	Digital Gangsta	SynLd	H Hop	1
96	F16	Plastic Squeeze	SynLd	H Hop	1
97	G01	Pinz Lead	SynLd	H Hop	1
98	G02	Dancy Saw Lead	SynLd	Dance	2
99	G03	Buzz Around	SynLd	Dance	3
100	G04	Xtreme Wheel	SynLd	Dance	2
101	G05	Supertrance	SynLd	Dance	4
102	G06	Poly Hook	SynLd	Dance	2
103	G07	HPF Dance	SynLd	Dance	2
104	G08	Tekk Glide	SynLd	Dance	2
105	G09	Growl Tekk	SynLd	Dance	1
106	G10	Plucked Chordz	SynLd	Dance	4
107	G11	Chordz	SynLd	Dance	4
108	G12	Cool Body	SynLd	Dance	4
109	G13	Twist Sync	SynLd	Dance	2
110	G14	TEKIE	SynLd	Dance	4
111	G15	Sonix	SynLd	Dance	3
112	G16	Big Skid Hook Lead 1	SynLd	Dance	4
113	H01	Big Skid Hook Lead 2	SynLd	Dance	4
114	H02	Porta Queen	SynLd	Arp	2
115	H03	Vicious Dogs	SynLd	Arp	4
116	H04	Saw Pad	Pads	Analg	4
117	H05	Dark Modulation Pad	Pads	Analg	2
118	H06	Dark Light	Pads	Warm	2
119	H07	Ambient Synthpad	Pads	Analg	2
120	H08	5th Lite	Pads	Analg	4
121	H09	Smooth BPF Sweep	Pads	Analg	2
122	H10	High Wire	Pads	Analg	2
123	H11	Trance MW	Pads	Analg	2
124	H12	Xtreme Sweep	Pads	Analg	2
125	H13	Nu WarmPad	Pads	Warm	2
126	H14	5th Atmosphere	Pads	Warm	4
127	H15	Dim	Pads	Warm	1
128	H16	Simple Air	Pads	Warm	2

PRE6 (MSB=63, LSB=5)

Number	Voice Name	Category		Element	
		Main	Sub		
1	A01	Nature Sine	Pads	Warm	3
2	A02	Analog	Pads	Warm	2
3	A03	Perc Pad	Pads	Warm	4
4	A04	Dark Atmo Pad	Pads	Warm	4
5	A05	Dark Organ Pad	Pads	Warm	2
6	A06	Soft Brassy	Pads	Warm	2
7	A07	Road to Nowhere	Pads	Warm	4
8	A08	Sweep Strings	Pads	Warm	3
9	A09	Brass Motion Pad	Pads	Warm	2
10	A10	Luminous	Pads	Warm	4
11	A11	Mother Ship	Pads	Choir	4
12	A12	Warm Backing Pad	Pads	Warm	2
13	A13	Feather	Pads	Warm	4
14	A14	Pan Sphere	Pads	Warm	4
15	A15	Square	Pads	Analg	2
16	A16	Shaper	Pads	Brite	2
17	B01	Early Digital	Pads	Warm	3
18	B02	Dramana	Pads	Brite	3
19	B03	Dream Shift	Pads	Brite	4
20	B04	Remote Space	Pads	Warm	2
21	B05	Fathoms	Pads	Warm	4
22	B06	SY22 2007	Pads	Warm	1
23	B07	Mother Earth	Pads	Warm	3
24	B08	Landing Pad	Pads	Warm	2
25	B09	The Breath	Pads	Brite	4
26	B10	Humanity	Pads	Warm	2
27	B11	Vowel Pad	Pads	Choir	4
28	B12	Feather Pad	Pads	Brite	2
29	B13	Slow Attack Pad	Pads	Brite	2
30	B14	Hi Brite	Pads	Brite	2
31	B15	Pad & Syn	Pads	Brite	4
32	B16	Cosmic Swell Pad	Pads	Brite	4
33	C01	Sweet Flange	Pads	Brite	4
34	C02	Waterfall	Pads	Brite	4
35	C03	Phase Pad	Pads	Brite	1
36	C04	Pure Synth	Pads	Brite	4
37	C05	Pearls	Pads	Brite	4
38	C06	Flange Wall	Pads	Brite	1
39	C07	Tornado	Pads	Brite	2
40	C08	Ice Rink	Pads	Brite	4
41	C09	Turbulence	Pads	Brite	1
42	C10	Bell Pad	Pads	Brite	4
43	C11	Paradise	Pads	Brite	1
44	C12	Yellow River	Pads	Brite	4
45	C13	Love Me	Pads	Brite	4
46	C14	Frozen Pad	Pads	Brite	4
47	C15	Pensive	Pads	Warm	4
48	C16	Space Vocals	Pads	Choir	3
49	D01	Haah Pad	Pads	Choir	4
50	D02	Oooh Pad	Pads	Choir	4
51	D03	Back in Itopian	Pads	Choir	4
52	D04	Strings & Choir	Pads	Choir	4
53	D05	Angel Eyes	Pads	Choir	3
54	D06	Glass Choir	Pads	Choir	4
55	D07	Nativity	Pads	Choir	4
56	D08	Seraphim	Pads	Choir	4
57	D09	Analog Shine	Pads	Arp	2
58	D10	Cosmic Gate	Pads	Arp	4
59	D11	Catching Wild Horses	Pads	Arp	2
60	D12	High Pass Gate	Pads	Arp	2
61	D13	Rhythmic Filterpad 1	Pads	Arp	2
62	D14	Rhythmic Filterpad 2	Pads	Arp	2
63	D15	P5 Resonance Comp	SyCmp	Analg	3
64	D16	P5 Analog Punch	SyCmp	Analg	3

Number	Voice Name	Category		Element	
		Main	Sub		
65	E01	Cool Trance	SyCmp	Analg	2
66	E02	>Attack<	SyCmp	Analg	2
67	E03	Club Finger	SyCmp	Analg	3
68	E04	Wobbly RB	SyCmp	Analg	2
69	E05	Ana Dayz	SyCmp	Analg	4
70	E06	Airy Nylon	SyCmp	Analg	4
71	E07	Progressive Attack	SyCmp	Analg	3
72	E08	Oracle	SyCmp	Analg	3
73	E09	Big Comp	SyCmp	Digitl	4
74	E10	Rezz Punch	SyCmp	Digitl	4
75	E11	Resonant Clavi	SyCmp	Digitl	1
76	E12	Straight RB	SyCmp	Digitl	3
77	E13	Psych Noise	SyCmp	Digitl	4
78	E14	Squiffy Misbehaving	SyCmp	Digitl	3
79	E15	Lektro Codes	SyCmp	Digitl	3
80	E16	Hard FM Keys	SyCmp	Digitl	2
81	F01	W Phaser	SyCmp	Digitl	2
82	F02	DPCM Attack	SyCmp	Digitl	2
83	F03	Talk	SyCmp	Digitl	3
84	F04	Digy_SEQ	SyCmp	Arp	3
85	F05	Nerve Nasty	SyCmp	Arp	3
86	F06	Ring_Zplus	SyCmp	Digitl	2
87	F07	Trance Attack	SyCmp	Digitl	3
88	F08	Tekno Attack AF1&2	SyCmp	Digitl	3
89	F09	PWM Percussion	SyCmp	Digitl	2
90	F10	Stabby	SyCmp	Digitl	3
91	F11	Detroit Stab	SyCmp	Digitl	3
92	F12	Corrado	SyCmp	Digitl	3
93	F13	Synthetique	SyCmp	Digitl	1
94	F14	Noiz Rezz	SyCmp	Digitl	3
95	F15	Tuxedo	SyCmp	Digitl	4
96	F16	Queens	SyCmp	Digitl	3
97	G01	Hip Voice	SyCmp	Digitl	2
98	G02	GX1	SyCmp	Fade	4
99	G03	Night Watch	SyCmp	Fade	3
100	G04	Pluck Bells	SyCmp	Fade	4
101	G05	Power Dance Chords	SyCmp	Hook	4
102	G06	Hyper Trance	SyCmp	Digitl	4
103	G07	Cosmic Psyche	SyCmp	Digitl	3
104	G08	Chillin' Chords	SyCmp	Arp	2
105	G09	Dirty Chordz	SyCmp	Arp	4
106	G10	Wild Horses	SyCmp	Arp	3
107	G11	Sixpack AF1&2	SyCmp	Arp	1
108	G12	Percussive Chords	SyCmp	Arp	2
109	G13	Chordmaster	SyCmp	Arp	2
110	G14	In the Mirror	SyCmp	Arp	1
111	G15	Come together!	SyCmp	Arp	1
112	G16	Happy Hour	SyCmp	Arp	2
113	H01	Recycling	SyCmp	Arp	2
114	H02	Digital Dreaming	SyCmp	Arp	4
115	H03	Carpenter's Wife	SyCmp	Arp	1
116	H04	Electronic Games	SyCmp	Arp	2
117	H05	Dancing Waves	SyCmp	Arp	1
118	H06	Hit Factory	SyCmp	Arp	1
119	H07	Freaky Loop	SyCmp	Arp	1
120	H08	Mr. Wah!	SyCmp	Arp	2
121	H09	Chill Comp 1	SyCmp	Arp	1
122	H10	Chill Comp 2	M.EFX	Arp	1
123	H11	Kalimboidal	SyCmp	Arp	2
124	H12	Bippus	SyCmp	Arp	2
125	H13	Virtuoso Sequencia	SyCmp	Arp	3
126	H14	Fat Saw Arpeggio	SyCmp	Arp	2
127	H15	Trancious Line	SyCmp	Arp	1
128	H16	Metal Plate	SyCmp	Arp	3

PRE7 (MSB=63, LSB=6)

Number		Voice Name	Category		Element
			Main	Sub	
1	A01	Fifth Dancer	SyCmp	Arp	2
2	A02	Percussive Sequence	SyCmp	Arp	1
3	A03	Simply Faaat	SyCmp	Arp	2
4	A04	Bright Dance	SyCmp	Arp	2
5	A05	Quadro Tune	SyCmp	Arp	4
6	A06	Champ	SynLd	Arp	2
7	A07	Men In Yellow	S.EFX	Move	4
8	A08	Metamorphosis	S.EFX	Move	2
9	A09	Perplex	S.EFX	Move	2
10	A10	Outer Planet	S.EFX	Move	2
11	A11	Industrial	S.EFX	Move	2
12	A12	Space Walking	S.EFX	Move	1
13	A13	Scraper	S.EFX	Move	1
14	A14	SE_02 <Zero Two>	S.EFX	Move	3
15	A15	Talking Machines	S.EFX	Move	2
16	A16	Tobi Mage	S.EFX	Move	3
17	B01	Bitzz MW	S.EFX	Move	1
18	B02	Thexism	S.EFX	Move	4
19	B03	In My Head	S.EFX	Move	4
20	B04	Toda	S.EFX	Ambie	3
21	B05	Water Tank	S.EFX	Ambie	3
22	B06	Auto Trapeze	S.EFX	Ambie	4
23	B07	Harpist's Nightmare	S.EFX	Ambie	2
24	B08	Find Newgt!	S.EFX	Ambie	4
25	B09	Nile River	S.EFX	Natur	1
26	B10	New Age Atmo	S.EFX	Natur	4
27	B11	Wind Blows	S.EFX	Natur	4
28	B12	Fire!	S.EFX	Natur	4
29	B13	Scratching Machine	S.EFX	SciFi	2
30	B14	Goa Psyche	S.EFX	SciFi	2
31	B15	Wait For Bad Weather	S.EFX	SciFi	3
32	B16	Reverse The Audio	S.EFX	SciFi	2
33	C01	Radio Static	S.EFX	SciFi	2
34	C02	Modifier X	S.EFX	SciFi	2
35	C03	Surveillance	S.EFX	SciFi	1
36	C04	Noise FX	S.EFX	SciFi	1
37	C05	Sample&Hold Vintage	S.EFX	SciFi	1
38	C06	Lazerzz	S.EFX	SciFi	2
39	C07	uhohrr	S.EFX	SciFi	2
40	C08	On The Fritz	S.EFX	SciFi	1
41	C09	Scratch Thing MW	S.EFX	Arp	1
42	C10	Trash Can Lid Band	S.EFX	Arp	4
43	C11	Piston Engine	S.EFX	Arp	3
44	C12	Waka Waka Noize	S.EFX	Arp	4
45	C13	Argentina	S.EFX	SciFi	4
46	C14	Gate of Eden	M.EFX	Move	4
47	C15	Wave Journey	M.EFX	Move	8
48	C16	Whispering Ghosts	M.EFX	Move	4
49	D01	Nighttrain to Munich	M.EFX	Move	4
50	D02	Morning Dew	M.EFX	Move	4
51	D03	Calling Mr. Reso	M.EFX	Move	4
52	D04	2 Switches to Heaven	M.EFX	Move	4
53	D05	Cell Division	M.EFX	Move	1
54	D06	Jumping Needle	M.EFX	Move	1
55	D07	SEKAI-ISAN	M.EFX	Move	4
56	D08	Setsunai AF2	M.EFX	Move	4
57	D09	Week End	M.EFX	Move	4
58	D10	Dragonfly	S.EFX	SciFi	2
59	D11	TiRiPAD	M.EFX	Move	4
60	D12	Cluster	M.EFX	Move	4
61	D13	Xtreme Rezz	M.EFX	Move	4
62	D14	Bit Space	M.EFX	Move	3
63	D15	My Reality	M.EFX	Move	4
64	D16	Waterproof	M.EFX	Move	4

Number		Voice Name	Category		Element
			Main	Sub	
65	E01	Magnetics	M.EFX	Move	4
66	E02	Sand	M.EFX	Move	4
67	E03	Felicity	M.EFX	Move	4
68	E04	Vibrancy	M.EFX	Move	4
69	E05	Metallflake	M.EFX	Move	1
70	E06	Radio Venus	M.EFX	Move	4
71	E07	Elec Blue	M.EFX	Move	3
72	E08	Chyo Ethno	M.EFX	Move	4
73	E09	Metal Shaper	M.EFX	Move	1
74	E10	Calculator	M.EFX	Move	1
75	E11	konjoh BEAM	M.EFX	Move	4
76	E12	Blizzard	M.EFX	Ambie	2
77	E13	SINGING BOWL	M.EFX	Ambie	2
78	E14	Vektris	M.EFX	Ambie	1
79	E15	Metalvox Pad	M.EFX	Ambie	3
80	F01	Refraction	M.EFX	Ambie	3
81	F01	Philanger	M.EFX	Ambie	1
82	F02	Slippery Ambience	M.EFX	Move	1
83	F03	Ellipsotron	M.EFX	Move	2
84	F04	Envelope	M.EFX	Move	3
85	F05	Whatsis	M.EFX	Ambie	3
86	F06	Pearl Collection	M.EFX	Ambie	4
87	F07	Four Dimensions	M.EFX	Ambie	1
88	F08	Hallucination	M.EFX	Ambie	1
89	F09	Arctic Sequence	M.EFX	Ambie	1
90	F10	Drifting	M.EFX	Ambie	4
91	F11	Electraid	M.EFX	Ambie	4
92	F12	Bed Time Story	M.EFX	Ambie	2
93	F13	Clearing	M.EFX	Sweep	2
94	F14	Long HiPa	M.EFX	Sweep	4
95	F15	Quad Swell	M.EFX	Sweep	4
96	F16	New Stab	M.EFX	Hit	4
97	G01	Vinyl Hit	M.EFX	Hit	4
98	G02	Hit Me	M.EFX	Hit	4
99	G03	Ambient Bite	M.EFX	Hit	4
100	G04	Green Valley	M.EFX	Arp	4
101	G05	Everlasting Glory	M.EFX	Arp	4
102	G06	Thinking of You	M.EFX	Arp	4
103	G07	Festival of Harmony	M.EFX	Arp	4
104	G08	Paris at Night	M.EFX	Arp	4
105	G09	On my Way to UK	M.EFX	Arp	4
106	G10	Chillin' Ibiza	M.EFX	Arp	3
107	G11	Heavens Door	M.EFX	Arp	4
108	G12	Cocktail	M.EFX	Arp	2
109	G13	Vanilla	M.EFX	Arp	3
110	G14	Ibiza Groove	M.EFX	Arp	4
111	G15	Nylon Chill	M.EFX	Arp	4
112	G16	Xtreme Harp	M.EFX	Arp	3
113	H01	Trancing in the Rain	M.EFX	Arp	4
114	H02	Gated Detune	M.EFX	Arp	2
115	H03	Gated Choir	M.EFX	Arp	4
116	H04	Exotic	M.EFX	Arp	3
117	H05	Syncscraper	M.EFX	Arp	2
118	H06	Ethnotic	M.EFX	Arp	3
119	H07	ComSat	M.EFX	Arp	2
120	H08	Investikator	M.EFX	Arp	1
121	H09	Monkey Bars	M.EFX	Arp	2
122	H10	Chilltrancer	M.EFX	Arp	2
123	H11	Random Beatz	M.EFX	Arp	1
124	H12	Electro Hood	M.EFX	Arp	2
125	H13	My Subwoofers	M.EFX	Arp	3
126	H14	Mister Sinister	M.EFX	Arp	2
127	H15	Polyrhythm	M.EFX	Arp	4
128	H16	Blood Flow	M.EFX	Arp	3

PRE8 (MSB=63, LSB=7)

Number	Voice Name	Category		Element	
		Main	Sub		
1	A01	On The Verge	M.EFX	Arp	3
2	A02	Droid	M.EFX	Arp	2
3	A03	Worker Ant	M.EFX	Arp	4
4	A04	Chopp Lingo	M.EFX	Arp	2
5	A05	Vinyl Beatnik	M.EFX	Arp	4
6	A06	Drop Zone ARP	M.EFX	Arp	2
7	A07	Particle	M.EFX	Arp	2
8	A08	Simple Arp	M.EFX	Arp	1
9	A09	Cyber Cycle	M.EFX	Arp	1
10	A10	BollogPuls	M.EFX	Arp	4
11	A11	Octopus	M.EFX	Arp	2
12	A12	Electronic Beatz	M.EFX	Arp	1
13	A13	Dreamin' of You	M.EFX	Arp	4
14	A14	Brothers & Sisters	M.EFX	Arp	4
15	A15	Pizza No.1	M.EFX	Arp	3
16	A16	Electronix	M.EFX	Arp	2
17	B01	TekkNow	M.EFX	Arp	4
18	B02	Hollow Sequence	M.EFX	Arp	1
19	B03	Icicle	M.EFX	Arp	2
20	B04	Jegog	M.EFX	Arp	1
21	B05	Octo Strobe 1	M.EFX	Arp	1
22	B06	Octo Strobe 2	M.EFX	Arp	1
23	B07	Random Waves	M.EFX	Arp	1
24	B08	Semar	M.EFX	Arp	2
25	B09	Trailing Headlights	M.EFX	Arp	2
26	B10	Dream Winds	M.EFX	Arp	1
27	B11	Kemence	Ethnic	Bowed	2
28	B12	Kemen Wet	Ethnic	Bowed	3
29	B13	Yayli	Ethnic	Bowed	4
30	B14	Kawala	Ethnic	Bowed	1
31	B15	Santur	Ethnic	Struk	2
32	B16	Baglama	Ethnic	Pluk	3
33	C01	Kotoun	Ethnic	Pluk	3
34	C02	Kanun	Ethnic	Pluk	2
35	C03	Bouzuki	Ethnic	Pluk	3
36	C04	Oud Tremolo Vel	Ethnic	Pluk	1
37	C05	SazFeeze	Ethnic	Pluk	3
38	C06	Where Am I?	Ethnic	Pluk	3
39	C07	Sakura	Ethnic	Pluk	3
40	C08	Nomad	Ethnic	Pluk	2
41	C09	Pluk-o-dy	Ethnic	Pluk	3
42	C10	Tambura	Ethnic	Pluk	2
43	C11	Sitar MW	Ethnic	Pluk	2
44	C12	Tabla Zone	Ethnic	Struk	1
45	C13	Udu	Ethnic	Struk	2
46	C14	Djembe	Ethnic	Struk	2
47	C15	Dhol	Ethnic	Struk	2
48	C16	Khol	Ethnic	Struk	3
49	D01	Ney	Ethnic	Blown	1
50	D02	Zurna	Ethnic	Blown	1
51	D03	Pungi	Ethnic	Blown	2
52	D04	Shehnai 1	Ethnic	Blown	2
53	D05	Didgeridoo	Ethnic	Blown	2
54	D06	Snake Charmer	Ethnic	Blown	4
55	D07	Mythic Flute	Ethnic	Blown	4
56	D08	Ethnology	Ethnic	Arp	4
57	D09	Oztralian	Ethnic	Arp	2
58	D10	8Z Destruct	Dr/Pc	Arp	2
59	D11	8Z Jarrin	Dr/Pc	Arp	2
60	D12	8Z Romps	Dr/Pc	Arp	2
61	D13	8Z Glitch	Dr/Pc	Arp	2
62	D14	8Z Oxidized	Dr/Pc	Arp	2
63	D15	8Z D&B Machine	Dr/Pc	Arp	2
64	D16	8Z Down Tempo	Dr/Pc	Arp	2

Number	Voice Name	Category		Element	
		Main	Sub		
65	E01	8Z Early Lo-Fi	Dr/Pc	Arp	1
66	E02	8Z Noize Xpress	Dr/Pc	Arp	1
67	E03	8Z Trance Basics	Dr/Pc	Arp	1
68	E04	8Z Reverse Beatz	Dr/Pc	Arp	1
69	E05	8Z Crush Dance	Dr/Pc	Arp	1
70	E06	8Z Heavy Hearts	Dr/Pc	Arp	1
71	E07	8Z Chilly Breakz	Dr/Pc	Arp	1
72	E08	8Z Gated Beatz	Dr/Pc	Arp	1
73	E09	8Z Hip Hop Shakers	Dr/Pc	Arp	1
74	E10	8Z Blip Hop	Dr/Pc	Arp	1
75	E11	8Z Nastly Glitch	Dr/Pc	Arp	2
76	E12	8Z Scratch	Dr/Pc	Arp	1
77	E13	8Z Tod	Dr/Pc	Arp	1
78	E14	8Z Psychedelic 1	Dr/Pc	Arp	2
79	E15	8Z Psychedelic 2	Dr/Pc	Arp	2
80	E16	8Z Dub Element	Dr/Pc	Arp	2
81	F01	Mega Nylon	Guitar	A.Gtr	2
82	F02	Mega Steel	Guitar	A.Gtr	2
83	F03	Mega 12 Steel	Guitar	A.Gtr	4
84	F04	Mega 60s Clean	Guitar	E.Cln	1
85	F05	Mega 60s Chorus Combo	Guitar	E.Cln	1
86	F06	Mega 60s Tremolo	Guitar	E.Cln	1
87	F07	Mega 60s Blues Tone	Guitar	E.Cln	1
88	F08	Mega 60s Phaser	Guitar	E.Cln	1
89	F09	Mega 60s Tube Tone	Guitar	E.Dst	1
90	F10	Mega 60s Dist Stack	Guitar	E.Dst	1
91	F11	Mega 60s Road House	Guitar	E.Dst	1
92	F12	Mega 60s Small Blues	Guitar	E.Cln	1
93	F13	Mega 60s Pedal Wah	Guitar	E.Dst	1
94	F14	Mega 60s VCM T.Wah	Guitar	E.Dst	1
95	F15	Mega 60s T.Wah&Dist	Guitar	E.Dst	1
96	F16	Mega 60s Jet Flanger	Guitar	E.Dst	1
97	G01	Mega 1coil Clean	Guitar	E.Cln	1
98	G02	Mega 1coil Chorus	Guitar	E.Cln	1
99	G03	Mega 1coil Tremolo	Guitar	E.Cln	1
100	G04	Mega 1coil BluesTone	Guitar	E.Cln	1
101	G05	Mega 1coil Phaser	Guitar	E.Cln	1
102	G06	Mega 1coil Tube Tone	Guitar	E.Cln	1
103	G07	Mega 1coil Tube Amp1	Guitar	E.Dst	1
104	G08	Mega 1coil Tube Amp2	Guitar	E.Dst	1
105	G09	Mega 1coil Roadhouse	Guitar	E.Dst	1
106	G10	Mega 1coil VCM T.Wah	Guitar	E.Cln	1
107	G11	Mega 60s Clean Delay	Guitar	E.Cln	1
108	G12	Mega 60s Slap Clean	Guitar	E.Cln	1
109	G13	Mega 60s Slap Dist	Guitar	E.Cln	1
110	G14	Mega 1coil SlapClean	Guitar	E.Cln	1
111	G15	Mega 1coil Slap Dist	Guitar	E.Dst	1
112	G16	Mega1coilSlpPedalWah	Guitar	E.Cln	1
113	H01	Mega Ovdr Distortion	Guitar	E.Dst	2
114	H02	Mega Ovdr Fuzz	Guitar	E.Dst	2
115	H03	Mega Acoustic Bass	Bass	ABass	1
116	H04	Mega Finger+Harmonic	Bass	EBass	1
117	H05	Mega Fretless Bass	Bass	EBass	1
118	H06	Mega Pick Open Amped	Bass	EBass	1
119	H07	Mega Pick Mute Amped	Bass	EBass	1
120	H08	Mega Slap Bass	Bass	EBass	1
121	H09	Mega Finger+Slap	Bass	EBass	1
122	H10	Mega Finger+Pull Amp	Bass	EBass	1
123	H11	Mega Pick Open Mute	Bass	EBass	1
124	H12	Mega Pick OpMt Dark	Bass	EBass	1
125	H13	Vocoder with Delay	Vocoder	---	4
126	H14	Funky Vocoder	Vocoder	---	4
127	H15	Vocoder Pad 1	Vocoder	---	5
128	H16	Vocoder Pad 2	Vocoder	---	4

USR1 (MSB=63, LSB=8)

USR2 (MSB=63, LSB=9)

USR3 (MSB=63, LSB=10)

Any of the Preset Voices is pre-stored to each voice number of the User Banks.

GM (MSB=0, LSB=0)

Number		Voice Name	Category		Element
			Main	Sub	
1	A01	Concert Grand Piano	Piano	APno	2
2	A02	Rock Brite Piano	Piano	APno	1
3	A03	CP 2007	Piano	Vintg	1
4	A04	Honkytonk	Piano	APno	4
5	A05	E.Piano 1	Keys	EP	1
6	A06	E.Piano 2	Keys	FM	2
7	A07	Harpsichord	Keys	Clavi	1
8	A08	Brite Clavi	Keys	Clavi	1
9	A09	Celesta	CPerc	Malet	1
10	A10	Glocken	CPerc	Malet	1
11	A11	Music Box	CPerc	Bell	3
12	A12	Vibes	CPerc	Malet	2
13	A13	Marimba	CPerc	Malet	2
14	A14	Xylophone	CPerc	Malet	2
15	A15	Tubular Bell	CPerc	Bell	3
16	A16	Dulcimer	CPerc	PDrum	2
17	B01	Draw Organ	Organ	TnWhl	2
18	B02	Percussive Organ	Organ	TnWhl	2
19	B03	Rock Organ	Organ	TnWhl	2
20	B04	Church Organ	Organ	Pipe	3
21	B05	Reed Organ	Organ	Pipe	2
22	B06	Accordion	Organ	Pipe	1
23	B07	Harmonica	SaxWW	RPipe	1
24	B08	Tango Accordion	Organ	Pipe	1
25	B09	Nylon Guitar	Guitar	A.Gtr	2
26	B10	Steel Guitar	Guitar	A.Gtr	2
27	B11	Jazz Guitar	Guitar	E.Cln	2
28	B12	Clean Guitar	Guitar	E.Cln	1
29	B13	Mute Guitar	Guitar	E.Cln	1
30	B14	Overdrive Guitar	Guitar	E.Dst	2
31	B15	Distortion Guitar	Guitar	E.Dst	2
32	B16	Guitar Harmonics	Guitar	E.Dst	2
33	C01	Acoustic Bass	Bass	ABass	1
34	C02	Finger Bass	Bass	EBass	2
35	C03	Pick Bass	Bass	EBass	2
36	C04	Fretless Bass	Bass	EBass	1
37	C05	Slap Bass 1	Bass	EBass	1
38	C06	Slap Bass 2 vel	Bass	EBass	1
39	C07	Synth Bass 1	Bass	SynBs	2
40	C08	Synth Bass 2	Bass	SynBs	2
41	C09	Violin	String	Solo	3
42	C10	Viola	String	Solo	3
43	C11	Cello	String	Solo	2
44	C12	Contrabass	String	Solo	2
45	C13	Tremolo Strings 2	String	Ensem	2
46	C14	Pizzicato	String	Pizz	2
47	C15	Harp	String	Pizz	1
48	C16	Timpani + Cymbal	CPerc	PDrum	4
49	D01	Strings Section 1	String	Ensem	2
50	D02	Strings Section 2	String	Ensem	2
51	D03	Synth Strings 1	String	Synth	3
52	D04	Synth Strings 2	String	Synth	3
53	D05	Aah Choir	Pads	Choir	2
54	D06	Ooh Choir	Pads	Choir	2
55	D07	Syn Voice	Pads	Choir	3
56	D08	Orchestra Hit	M.EFX	Hit	4
57	D09	Trumpet 2	Brass	Solo	1
58	D10	Trombone 2	Brass	Solo	1
59	D11	Tuba	Brass	Solo	1
60	D12	Mute Trumpet	Brass	Solo	1
61	D13	French Horns	Brass	Orche	2
62	D14	Brass Section	Brass	BrsEn	3
63	D15	Synth Brass 1	Brass	Synth	3
64	D16	Synth Brass 2	Brass	Synth	3

Number		Voice Name	Category		Element
			Main	Sub	
65	E01	Soprano Sax	SaxWW	Sax	3
66	E02	Alto Sax	SaxWW	Sax	1
67	E03	Tenor Sax	SaxWW	Sax	2
68	E04	Baritone Sax	SaxWW	Sax	1
69	E05	Oboe 2	SaxWW	RPipe	2
70	E06	English Horn	SaxWW	RPipe	1
71	E07	Bassoon 2	SaxWW	RPipe	2
72	E08	Clarinet 2	SaxWW	RPipe	3
73	E09	Piccolo	SaxWW	Flute	1
74	E10	Flute	SaxWW	Flute	2
75	E11	Recorder	SaxWW	WWind	1
76	E12	Panflute	SaxWW	Flute	1
77	E13	Bottle	SaxWW	Flute	2
78	E14	Shakuhachi	SaxWW	Flute	2
79	E15	Whistle	SaxWW	WWind	2
80	E16	Ocarina	SaxWW	WWind	2
81	F01	Square Lead	SynLd	Analg	2
82	F02	Saw Lead	SynLd	Analg	2
83	F03	Calliope Lead	SynLd	Analg	2
84	F04	Chiff Lead	SynLd	Analg	1
85	F05	Charan Lead	SynLd	Digitl	2
86	F06	Voice Lead	SynLd	Analg	4
87	F07	Fifth Lead	SynLd	Analg	2
88	F08	Bass & Lead	SynLd	Analg	1
89	F09	New Age Pad	Pads	Brite	2
90	F10	Warm Pad	Pads	Warm	2
91	F11	Poly Synth Pad	Pads	Analg	2
92	F12	Choir Pad	Pads	Choir	3
93	F13	Bowed Pad	Pads	Warm	2
94	F14	Metal Pad	Pads	Brite	2
95	F15	Halo Pad	Pads	Brite	2
96	F16	Sweep Pad	Pads	Brite	4
97	G01	Rain Pad	M.EFX	Move	2
98	G02	Sound Track	Pads	Brite	3
99	G03	Crystal	CPerc	Bell	3
100	G04	Atmosphere	Pads	Warm	3
101	G05	Brightness	SyCmp	Digitl	2
102	G06	Goblin	M.EFX	Sweep	2
103	G07	Echoes	M.EFX	Move	3
104	G08	Sci-Fi	Pads	Brite	2
105	G09	Sitar	Ethnic	Pluk	1
106	G10	Banjo	Ethnic	Pluk	1
107	G11	Shamisen	Ethnic	Pluk	1
108	G12	Koto	Ethnic	Pluk	2
109	G13	Kalimba	CPerc	Malet	2
110	G14	Bagpipe	SaxWW	RPipe	2
111	G15	Fiddle	Ethnic	Bowed	2
112	G16	Shehnai 2	SaxWW	WWind	1
113	H01	Tinkle Bell	CPerc	Bell	2
114	H02	Agogo	Dr/Pc	Perc	1
115	H03	Steel Drum	CPerc	PDrum	2
116	H04	Woodblock	Dr/Pc	Perc	1
117	H05	Taiko Drum	Dr/Pc	Perc	2
118	H06	Melodic Tom	Dr/Pc	Drums	1
119	H07	Synth Drum	Dr/Pc	Drums	1
120	H08	Reverse Cymbal	S.EFX	Move	1
121	H09	Fret Noise	S.EFX	Natur	2
122	H10	Breath Noiz	S.EFX	Natur	1
123	H11	Seashore	S.EFX	Natur	2
124	H12	Tweet	S.EFX	Natur	1
125	H13	Telephone	S.EFX	Natur	1
126	H14	Helicopter	S.EFX	Natur	2
127	H15	Applause	S.EFX	Natur	2
128	H16	Gunshot	S.EFX	Natur	1

Drum Voice List

Drum Voice Name List

Preset (MSB=63, LSB=32)

Pre No.	Voice Name	
1	Power Standard Kit 1	These drum kits have been specially programmed for different music styles, yet closely follow the standard instrument order of the GM kit.
2	Power Standard Kit 2	
3	Hyper Standard Kit	
4	Dry Standard Kit	
5	Modern Rock Kit	
6	Rock Stereo Kit 1	
7	Rock Stereo Kit 2	
8	Nu Hip Hop Kit 1	
9	Nu Hip Hop Kit 2	
10	Hip Hop Kit 1	
11	Hip Hop Kit 2	
12	Hip Hop Kit 3	
13	Hip Hop Kit 5	
14	Hip Stick Kit 1	
15	Hip Stick Kit 2	
16	R&B Kit 1	
17	R&B Kit 2	
18	R&B Kit 3	
19	Trance Kit	
20	Psychedelic Kit	
21	Chill Out Kit	
22	Brush Kit	
23	Jazz Kit	
24	Pop Latin Kit	
25	Analog T9 Kit	
26	Analog T8 Kit	
27	Tekno Kit	
28	House Kit 1	
29	House Kit 2	
30	House Compressed Kit	
31	Big Kit	
32	Break Kit	
33	Drum'n'Bass Kit	
34	Acid Kit	
35	Jungle Kit	
36	Electric Kit	
37	Human Kit	
38	Hard Kit	
39	Distorted Kit	
40	Ambient Kit	
41	Garage Kit	These original drum kits, programmed for the MOX6/MOX8, feature a special non-standard order for ease in playing.
42	Synth Pop Kit	
43	Orchestra Kit	
44	Drum Machines Kit	
45	Rock Multiple Kits	
46	HipHop Multiple Kits	
47	Percussion Kit	These original kits feature a variety of instruments and special sound effects, and are grouped according to their type.
48	Latin Percussion Kit	
49	Guitar/Bass FX Kit	
50	Wacko Kit	
51	Wood Bits Kit	
52	Metal Bits Kit	
53	Hands Kit	
54	Scratches	
55	Accoustic Snares	
56	GroupedStereo Snares	
57	All Kicks	
58	Dance Kicks	
59	Arabic Mixed Kit	
60	Belly Dance Kit	
61	Dance Snares	
62	Special SFXs	
63	Synthetic Kit	
64	SFX Kit	

GM (MSB=127, LSB=0)

GM Drum No.	Voice Name	
1	Stereo GM Kit	

Drum Kit Assign List

PRE 1 Power Standard Kit 1

Note	Wave Number	Wave Name
C0	1449	Clave
C#0	2046	Sd Brush Soft St
D0	2058	Sd Brush Swir St
D#0	2049	Sd Brush Med St
E0	2061	Sd Brush SwirAtt St
F0	2042	Sd LiveRoll St
F#0	1448	Castanet
G0	1993	Sd PowerD 1St
G#0	1446	Stick1
A0	1595	Bd PowerB 1-2St
A#0	2005	Sd PowerD 5St
B0	1586	Bd PowerA 1-2St
C1	1574	Bd Jazz1-2St
C#1	1963	Sd PowerB SSt
D1	1966	Sd PowerC 1-5St
D#1	1456	HandClap St
E1	1987	Sd PowerD 1-5St
F1	2415	Tom Power05 1-2St
F#1	2273	HH Power ClTip 1-4St
G1	2415	Tom Power05 1-2St
G#1	2313	HH Power ClPedal St
A1	2403	Tom Power04 1-2St
A#1	2317	HH Power Open EdgeSt
B1	2391	Tom Power03 1-2St
C2	2391	Tom Power03 1-2St
C#2	2461	Crash2 St
D2	2379	Tom Power01 1-2St
D#2	2485	Ride1 St
E2	2512	China St
F2	2493	Ride Cup1 St
F#2	1419	Tambourine1 Sw
G2	2517	Splash St
G#2	1462	Cowbell2
A2	2464	Crash2 RL
A#2	1451	Vibraslap
B2	2489	Ride2 St
C3	1363	Bongo Hi 1Finger 1-2
C#3	1373	Bongo Lo 1Finger 1-2
D3	1343	Conga Hi SlapMute1-2
D#3	1337	Conga Hi Open 1-2
E3	1348	Conga Lo Open 1-2
F3	1381	Timbale Hi1-3
F#3	1385	Timbale Lo1-2
G3	1429	Agogo Hi
G#3	1430	Agogo Lo
A3	1399	Cabasa1-2
A#3	1397	Maracas Slur
B3	1452	Whistle
C4	1452	Whistle
C#4	1433	Guiro Short
D4	1432	Guiro Long
D#4	1449	Clave
E4	1450	Wood Block
F4	1450	Wood Block
F#4	1362	Cuica Hi
G4	1361	Cuica Lo
G#4	1455	Triangle Mute
A4	1454	Triangle Open
A#4	1405	Shaker 1/3
B4	1467	Sleigh Bell
C5	1468	Wind Chime
C#5	1682	Sd Bld St1-4
D5	1841	Sd Blues 3St
D#5	1885	Sd Hip St1-2
E5	1782	Sd Funk St1-3
F5	1702	Sd Soul St1-4
F#5	2010	Sd LdwHMMono
G5	2013	Sd Heavy
G#5	1865	Sd Tight St1-4
A5	1850	Sd BluesHeart St1-3
A#5	1500	Bd Snap 1-2
B5	1509	Bd Tight 1-2
C6	1536	Bd Funk St1-2

PRE 2 Power Standard Kit 2

Note	Wave Number	Wave Name
C0	1449	Clave
C#0	2046	Sd Brush Soft St
D0	2058	Sd Brush Swir St
D#0	2049	Sd Brush Med St
E0	2061	Sd Brush SwirAtt St
F0	2042	Sd LiveRoll St
F#0	1448	Castanet
G0	1927	Sd PowerA 1St
G#0	1446	Stick1
A0	1595	Bd PowerB 1-2St
A#0	1939	Sd PowerA 5St
B0	1586	Bd PowerA 1-2St
C1	1574	Bd Jazz1-2St
C#1	1963	Sd PowerB SSt
D1	1942	Sd PowerB 1-5St
D#1	1456	HandClap St
E1	1921	Sd PowerA 1-5St
F1	2415	Tom Power05 1-2St
F#1	2293	HH Power ClEdge1-4St
G1	2415	Tom Power05 1-2St
G#1	2313	HH Power ClPedal St
A1	2403	Tom Power04 1-2St
A#1	2317	HH Power Open EdgeSt
B1	2391	Tom Power03 1-2St
C2	2391	Tom Power03 1-2St
C#2	2461	Crash2 St
D2	2379	Tom Power01 1-2St
D#2	2485	Ride1 St
E2	2512	China St
F2	2493	Ride Cup1 St
F#2	1419	Tambourine1 Sw
G2	2517	Splash St
G#2	1462	Cowbell2
A2	2464	Crash2 RL
A#2	1451	Vibraslap
B2	2489	Ride2 St
C3	1363	Bongo Hi 1Finger 1-2
C#3	1373	Bongo Lo 1Finger 1-2
D3	1343	Conga Hi SlapMute1-2
D#3	1337	Conga Hi Open 1-2
E3	1348	Conga Lo Open 1-2
F3	1381	Timbale Hi1-3
F#3	1385	Timbale Lo1-2
G3	1429	Agogo Hi
G#3	1430	Agogo Lo
A3	1399	Cabasa1-2
A#3	1397	Maracas Slur
B3	1452	Whistle
C4	1452	Whistle
C#4	1433	Guiro Short
D4	1432	Guiro Long
D#4	1449	Clave
E4	1450	Wood Block
F4	1450	Wood Block
F#4	1362	Cuica Hi
G4	1361	Cuica Lo
G#4	1455	Triangle Mute
A4	1454	Triangle Open
A#4	1405	Shaker 1/3
B4	1467	Sleigh Bell
C5	1468	Wind Chime
C#5	1682	Sd Bld St1-4
D5	1841	Sd Blues 3St
D#5	1885	Sd Hip St1-2
E5	1782	Sd Funk St1-3
F5	1702	Sd Soul St1-4
F#5	2010	Sd LdwHMMono
G5	2013	Sd Heavy
G#5	1865	Sd Tight St1-4
A5	1850	Sd BluesHeart St1-3
A#5	1500	Bd Snap 1-2
B5	1509	Bd Tight 1-2
C6	1536	Bd Funk St1-2

PRE 3 Hyper Standard Kit

Note	Wave Number	Wave Name
C0	1449	Clave
C#0	2046	Sd Brush Soft St
D0	2058	Sd Brush Swir St
D#0	2049	Sd Brush Med St
E0	2061	Sd Brush SwirAtt St
F0	2042	Sd LiveRoll St
F#0	1448	Castanet
G0	1768	Sd Normal 1St
G#0	1446	Stick1
A0	1557	Bd Funk Son St
A#0	1800	Sd Basic St1-3
B0	1501	Bd Snap 1
C1	1551	Bd H Son St
C#1	2031	Sd Closed Rim St
D1	1815	Sd SonA St1-4
D#1	1469	Clap T9
E1	1865	Sd Tight St1-4
F1	2363	Tom Floor St
F#1	2222	HH Closed Foot St
G1	2363	Tom Floor St
G#1	2226	HH Half Open2 St
A1	2359	Tom Low St
A#1	2230	HH Open2 St
B1	2359	Tom Low St
C2	2355	Tom Mid St
C#2	2464	Crash2 RL
D2	2351	Tom Hi St
D#2	2485	Ride1 St
E2	2512	China St
F2	2493	Ride Cup1 St
F#2	1419	Tambourine1 Sw
G2	2517	Splash St
G#2	1462	Cowbell2
A2	2464	Crash2 RL
A#2	1451	Vibraslap
B2	2488	Ride1 RL
C3	1363	Bongo Hi 1Finger 1-2
C#3	1376	Bongo Lo 3Finger 1-2
D3	1335	Conga Hi Tip
D#3	1339	Conga Hi Open 2
E3	1357	Tumba Open
F3	1381	Timbale Hi1-3
F#3	1385	Timbale Lo1-2
G3	1429	Agogo Hi
G#3	1430	Agogo Lo
A3	1399	Cabasa1-2
A#3	1397	Maracas Slur
B3	1452	Whistle
C4	1452	Whistle
C#4	1433	Guiro Short
D4	1432	Guiro Long
D#4	1449	Clave
E4	1450	Wood Block
F4	1450	Wood Block
F#4	1362	Cuica Hi
G4	1361	Cuica Lo
G#4	1455	Triangle Mute
A4	1454	Triangle Open
A#4	1406	Shaker 1
B4	1467	Sleigh Bell
C5	1468	Wind Chime
C#5	1682	Sd Bld St1-4
D5	1835	Sd Blues St1-3
D#5	1858	Sd BluesHeart R1-3
E5	1885	Sd Hip St1-2
F5	1762	Sd Normal St1-4
F#5	2010	Sd LdwHMMono
G5	1703	Sd Soul St1-3
G#5	2013	Sd Heavy
A5	1786	Sd Funk 1St
A#5	1528	Bd Normal 1St
B5	1557	Bd Funk Son St
C6	1500	Bd Snap 1-2

PRE 4 Dry Standard Kit

Note	Wave Number	Wave Name
C0	1449	Clave
C#0	2046	Sd Brush Soft St
D0	2058	Sd Brush Swir St
D#0	2049	Sd Brush Med St
E0	2061	Sd Brush SwirAtt St
F0	2042	Sd LiveRoll St
F#0	1448	Castanet
G0	1768	Sd Normal 1St
G#0	1446	Stick1
A0	1536	Bd Funk St1-2
A#0	1802	Sd Basic St2-3
B0	1545	Bd High St
C1	1527	Bd Normal St1-2
C#1	2031	Sd Closed Rim St
D1	1762	Sd Normal St1-4
D#1	1469	Clap T9
E1	1801	Sd Basic St1-2
F1	2363	Tom Floor St
F#1	2174	HH Closed 1-4St
G1	2363	Tom Floor St
G#1	2197	HH Pedal 3 St
A1	2359	Tom Low St
A#1	2210	HH Open 1-2St
B1	2359	Tom Low St
C2	2355	Tom Mid St
C#2	2464	Crash2 RL
D2	2351	Tom Hi St
D#2	2485	Ride1 St
E2	2512	China St
F2	2493	Ride Cup1 St
F#2	1419	Tambourine1 Sw
G2	2517	Splash St
G#2	1462	Cowbell2
A2	2464	Crash2 RL
A#2	1451	Vibraslap
B2	2488	Ride1 RL
C3	1363	Bongo Hi 1Finger 1-2
C#3	1376	Bongo Lo 3Finger 1-2
D3	1341	Conga Hi Slip Open
D#3	1339	Conga Hi Open 2
E3	1357	Tumba Open
F3	1381	Timbale Hi1-3
F#3	1385	Timbale Lo1-2
G3	1429	Agogo Hi
G#3	1430	Agogo Lo
A3	1399	Cabasa1-2
A#3	1397	Maracas Slur
B3	1452	Whistle
C4	1452	Whistle
C#4	1433	Guiro Short
D4	1432	Guiro Long
D#4	1449	Clave
E4	1450	Wood Block
F4	1450	Wood Block
F#4	1362	Cuica Hi
G4	1361	Cuica Lo
G#4	1455	Triangle Mute
A4	1454	Triangle Open
A#4	1406	Shaker 1
B4	1467	Sleigh Bell
C5	1468	Wind Chime
C#5	1682	Sd Bld St1-4
D5	1842	Sd Blues L1-3
D#5	1885	Sd Hip St1-2
E5	1782	Sd Funk St1-3
F5	1704	Sd Soul St2-4
F#5	2010	Sd LdwHMMono
G5	2013	Sd Heavy
G#5	1865	Sd Tight St1-4
A5	1853	Sd BluesHeart St1/3
A#5	1500	Bd Snap 1-2
B5	1509	Bd Tight 1-2
C6	1536	Bd Funk St1-2

PRE 5 Modern Rock Kit

Note	Wave Number	Wave Name
C0	1449	Clave
C#0	2046	Sd Brush Soft St
D0	2058	Sd Brush Swir St
D#0	2049	Sd Brush Med St
E0	2061	Sd Brush SwirAtt St
F0	2042	Sd LiveRoll St
F#0	1448	Castanet
G0	1896	Sd Rock Open1 R
G#0	1446	Stick1
A0	1571	Bd Room1
A#0	1751	Sd Rng St4
B0	1580	Bd Jazz2St
C1	1573	Bd Room3
C#1	2018	Sd Rock Stick2 St
D1	1722	Sd Strong St1-4
D#1	1493	HipHop clap6
E1	1921	Sd PowerA 1-5St
F1	2363	Tom Floor St
F#1	2234	HH Closed Rock Sw St
G1	2359	Tom Low St
G#1	2262	HH Half Open Rock St
A1	2359	Tom Low St
A#1	2260	HH Open Rock St
B1	2355	Tom Mid St
C2	2355	Tom Mid St
C#2	2460	Crash1 RL
D2	2351	Tom Hi St
D#2	2489	Ride2 St
E2	2512	China St
F2	2505	Ride Cup2 St
F#2	1419	Tambourine1 Sw
G2	2517	Splash St
G#2	1462	Cowbell2
A2	2457	Crash1 St
A#2	1451	Vibraslap
B2	2496	Ride Cup1 RL
C3	1363	Bongo Hi 1Finger 1-2
C#3	1376	Bongo Lo 3Finger 1-2
D3	1335	Conga Hi Tip
D#3	1339	Conga Hi Open 2
E3	1357	Tumba Open
F3	1381	Timbale Hi1-3
F#3	1385	Timbale Lo1-2
G3	1429	Agogo Hi
G#3	1430	Agogo Lo
A3	1399	Cabasa1-2
A#3	1397	Maracas Slur
B3	1452	Whistle
C4	1452	Whistle
C#4	1433	Guiro Short
D4	1432	Guiro Long
D#4	1449	Clave
E4	1450	Wood Block
F4	1450	Wood Block
F#4	1362	Cuica Hi
G4	1361	Cuica Lo
G#4	1455	Triangle Mute
A4	1454	Triangle Open
A#4	1406	Shaker 1
B4	1467	Sleigh Bell
C5	1468	Wind Chime
C#5	1838	Sd Blues St1/3
D5	1865	Sd Tight St1-4
D#5	1858	Sd BluesHeart R1-3
E5	1876	Sd Tight R1-4
F5	1548	Bd Low St
F#5	1981	Sd PowerC 4St
G5	1633	Bd R&B1
G#5	1942	Sd PowerB 1-5St
A5	1571	Bd Room1
A#5	1921	Sd PowerA 1-5St
B5	1557	Bd Funk Son St
C6	1572	Bd Room2

PRE 6 Rock Stereo Kit 1

Note	Wave Number	Wave Name
C0	1487	Analog Click
C#0	2046	Sd Brush Soft St
D0	2058	Sd Brush Swir St
D#0	2049	Sd Brush Med St
E0	2061	Sd Brush SwirAtt St
F0	2036	Sd RockRoll St
F#0	1448	Castanet
G0	1903	Sd Rock Open2 St
G#0	1446	Stick1
A0	1573	Bd Room3
A#0	1900	Sd Rock Rim1 St
B0	1563	Bd Rock2 St
C1	1560	Bd Rock1 St
C#1	2015	Sd Rock Stick1 St
D1	1894	Sd Rock Open1 St
D#1	1490	HipHop clap3
E1	1897	Sd Rock Mute1 St
F1	2375	Tom Rock Low St
F#1	2234	HH Closed Rock Sw St
G1	2375	Tom Rock Low St
G#1	2246	HH Pedal Rock Sw St
A1	2371	Tom Rock Mid St
A#1	2258	HH Open Rock Sw St
B1	2371	Tom Rock Mid St
C2	2367	Tom Rock Hi St
C#2	2460	Crash1 RL
D2	2367	Tom Rock Hi St
D#2	2489	Ride2 St
E2	2512	China St
F2	2505	Ride Cup2 St
F#2	1479	Tambourine RX5
G2	2517	Splash St
G#2	1461	Cowbell1
A2	2457	Crash1 St
A#2	1451	Vibraslap
B2	2492	Ride2 RL
C3	1363	Bongo Hi 1Finger 1-2
C#3	1376	Bongo Lo 3Finger 1-2
D3	1335	Conga Hi Tip
D#3	1339	Conga Hi Open 2
E3	1357	Tumba Open
F3	1381	Timbale Hi1-3
F#3	1385	Timbale Lo1-2
G3	1429	Agogo Hi
G#3	1430	Agogo Lo
A3	1399	Cabasa1-2
A#3	1397	Maracas Slur
B3	1452	Whistle
C4	1452	Whistle
C#4	1433	Guiro Short
D4	1432	Guiro Long
D#4	1449	Clave
E4	1450	Wood Block
F4	1450	Wood Block
F#4	1362	Cuica Hi
G4	1361	Cuica Lo
G#4	1455	Triangle Mute
A4	1454	Triangle Open
A#4	1406	Shaker 1
B4	1467	Sleigh Bell
C5	1468	Wind Chime
C#5	1912	Sd Rock Flam St
D5	1903	Sd Rock Open2 St
D#5	1909	Sd Rock Rim2 St
E5	1906	Sd Rock Mute2 St
F5	1537	Bd Funk 1St
F#5	2039	Sd RockRollID St
G5	1551	Bd H Son St
G#5	1865	Sd Tight St1-4
A5	1557	Bd Funk Son St
A#5	1823	Sd SonA 3St
B5	1540	Bd Funk R1-2
C6	1551	Bd H Son St

PRE 7 Rock Stereo Kit 2

Note	Wave Number	Wave Name
C0	1487	Analog Click
C#0	2046	Sd Brush Soft St
D0	2058	Sd Brush Swir St
D#0	2049	Sd Brush Med St
E0	2061	Sd Brush SwirAtt St
F0	2036	Sd RockRoll St
F#0	1448	Castanet
G0	1903	Sd Rock Open2 St
G#0	1446	Stick1
A0	1571	Bd Room1
A#0	1909	Sd Rock Rim2 St
B0	1521	Bd Ambience L1-2
C1	1563	Bd Rock2 St
C#1	2018	Sd Rock Stick2 St
D1	1903	Sd Rock Open2 St
D#1	1456	HandClap St
E1	1906	Sd Rock Mute2 St
F1	2375	Tom Rock Low St
F#1	2250	HH Closed Rock 2St
G1	2375	Tom Rock Low St
G#1	2262	HH Half Open Rock St
A1	2371	Tom Rock Mid St
A#1	2260	HH Open Rock St
B1	2371	Tom Rock Mid St
C2	2367	Tom Rock Hi St
C#2	2461	Crash2 St
D2	2367	Tom Rock Hi St
D#2	2489	Ride2 St
E2	2512	China St
F2	2505	Ride Cup2 St
F#2	1479	Tambourine RX5
G2	2517	Splash St
G#2	1461	Cowbell1
A2	2464	Crash2 RL
A#2	1451	Vibraslap
B2	2492	Ride2 RL
C3	1363	Bongo Hi 1Finger 1-2
C#3	1376	Bongo Lo 3Finger 1-2
D3	1335	Conga Hi Tip
D#3	1339	Conga Hi Open 2
E3	1357	Tumba Open
F3	1381	Timbale Hi1-3
F#3	1385	Timbale Lo1-2
G3	1429	Agogo Hi
G#3	1430	Agogo Lo
A3	1399	Cabasa1-2
A#3	1397	Maracas Slur
B3	1452	Whistle
C4	1452	Whistle
C#4	1433	Guiro Short
D4	1432	Guiro Long
D#4	1449	Clave
E4	1450	Wood Block
F4	1450	Wood Block
F#4	1362	Cuica Hi
G4	1361	Cuica Lo
G#4	1455	Triangle Mute
A4	1454	Triangle Open
A#4	1406	Shaker 1
B4	1467	Sleigh Bell
C5	1468	Wind Chime
C#5	1912	Sd Rock Flam St
D5	1894	Sd Rock Open1 St
D#5	1900	Sd Rock Rim1 St
E5	1897	Sd Rock Mute1 St
F5	1560	Bd Rock1 St
F#5	2039	Sd RockRollID St
G5	1538	Bd Funk 2St
G#5	1865	Sd Tight St1-4
A5	1545	Bd High St
A#5	1824	Sd SonA 4St
B5	1554	Bd L Son St
C6	1560	Bd Rock1 St

PRE 8 Nu Hip Hop Kit 1

Note	Wave Number	Wave Name
C0	1673	Bd HipHop2
C#0	1401	Cabasa2
D0	2165	Sd HipHop9
D#0	1318	Scratch Lo R
E0	1323	Scratch Vo F
F0	2039	Sd RockRollID St
F#0	1449	Clave
G0	2162	Sd HipHop5
G#0	2170	Sd HipHop Rim3
A0	1679	Bd HipHop8
A#0	2173	Sd HipHop Rim6
B0	1680	Bd HipHop9
C1	1676	Bd HipHop5
C#1	2169	Sd HipHop Rim2
D1	2167	Sd HipHop11
D#1	1489	HipHop clap2
E1	2160	Sd HipHop2
F1	2363	Tom Floor St
F#1	2341	HH Closed Hip
G1	2359	Tom Low St
G#1	2342	HH Pedal Hip
A1	2355	Tom Mid St
A#1	2343	HH Open Hip
B1	2351	Tom Hi St
C2	2351	Tom Hi St
C#2	2466	Crash4
D2	2351	Tom Hi St
D#2	2490	Ride2 L
E2	2461	Crash2 St
F2	2509	Ride Mono
F#2	1420	Tambourine 1 Hit
G2	2479	Hand Cymbal Open St
G#2	1465	Mambo Body
A2	2514	China R
A#2	1459	Handbell L
B2	2511	Ride Cup Mono2
C3	1341	Conga Hi Slip Open
C#3	1349	Conga Lo Open 1
D3	1346	Conga Lo Tip
D#3	1352	Conga Hi SlapOpen
E3	1350	Conga Lo Open 2
F3	1675	Bd HipHop4
F#3	1490	HipHop clap3
G3	1429	Agogo Hi
G#3	1430	Agogo Lo
A3	1407	Shaker 2
A#3	1406	Shaker 1
B3	1681	Bd HipHop10
C4	1677	Bd HipHop6
C#4	2171	Sd HipHop Rim4
D4	2163	Sd HipHop6
D#4	1498	HipHop Snap1
E4	1681	Bd HipHop10
F4	2164	Sd HipHop7
F#4	1488	HipHop clap1
G4	1391	Paila L
G#4	1455	Triangle Mute
A4	1454	Triangle Open
A#4	1419	Tambourine 1 Sw
B4	1407	Shaker 2
C5	1679	Bd HipHop8
C#5	1469	Clap T9
D5	2104	Sd T8-1
D#5	2104	Sd T8-1
E5	2107	Sd T8-4
F5	2451	Tom T8
F#5	2328	HH Closed T8-2
G5	2451	Tom T8
G#5	2328	HH Closed T8-2
A5	2451	Tom T8
A#5	2329	HH Open T8-2
B5	2451	Tom T8
C6	2522	Crash T8

PRE 9 Nu Hip Hop Kit 2

Note	Wave Number	Wave Name
C0	1674	Bd HipHop3
C#0	1292	Hi Q2
D0	1328	Scratch Hip2
D#0	1322	Scratch Sd R
E0	1324	Scratch Vo R
F0	2140	Sd Break Roll
F#0	2103	Sd T9Rim
G0	2160	Sd HipHop2
G#0	2109	Sd T8 Rim
A0	1680	Bd HipHop9
A#0	2168	Sd HipHop Rim1
B0	1677	Bd HipHop6
C1	1676	Bd HipHop5
C#1	2169	Sd HipHop Rim2
D1	2159	Sd HipHop1
D#1	1493	HipHop clap6
E1	2165	Sd HipHop9
F1	2450	Tom T9 Lo
F#1	2341	HH Closed Hip
G1	2450	Tom T9 Lo
G#1	2342	HH Pedal Hip
A1	2449	Tom T9 Hi
A#1	2343	HH Open Hip
B1	2449	Tom T9 Hi
C2	2451	Tom T8
C#2	2465	Crash3
D2	2451	Tom T8
D#2	2524	Ride T9
E2	2524	Ride T9
F2	2471	Crash Brush Cup St
F#2	1479	Tambourine RX5
G2	2523	Crash Syn
G#2	1476	Cowbell AnCR
A2	2521	Crash T9
A#2	1438	MetalGairo Long
B2	2509	Ride Mono
C3	1443	Cajon Tip 1-2
C#3	1380	Bongo Lo Tip
D3	1427	Tmbourim Finger
D#3	1417	Tumbo 2
E3	1360	Tumba Heel
F3	1392	Paila H
F#3	1391	Paila L
G3	1474	Cowbell T8
G#3	1476	Cowbell AnCR
A3	1414	Shekere Up
A#3	1403	Caxixi1
B3	1248	Grain2 St
C4	1249	Grain2 L
C#4	1444	Cajon Tip 1
D4	1494	HipHop clap7
D#4	1449	Clave
E4	1450	Wood Block
F4	2171	Sd HipHop Rim4
F#4	1498	HipHop Snap1
G4	1499	HipHop Snap2
G#4	1486	Electric Triangle
A4	1454	Triangle Open
A#4	1406	Shaker 1
B4	1438	MetalGairo Long
C5	1468	Wind Chime
C#5	2171	Sd HipHop Rim4
D5	2104	Sd T8-1
D#5	2105	Sd T8-2
E5	2107	Sd T8-4
F5	2451	Tom T8
F#5	2328	HH Closed T8-2
G5	2451	Tom T8
G#5	2328	HH Closed T8-2
A5	2451	Tom T8
A#5	2329	HH Open T8-2
B5	2451	Tom T8
C6	1496	HipHop flex1

PRE 10 Hip Hop Kit 1

Note	Wave Number	Wave Name
C0	2022	Sd Hip Stick2
C#0	1293	Vox Hit Rev
D0	1299	TurnTable
D#0	1172	Hit Brass
E0	1322	Scratch Sd R
F0	2044	Sd LiveRoll R
F#0	1485	Clave T8
G0	1893	Sd Hip 2R
G#0	2028	Sd Hip Stick6 R
A0	1680	Bd HipHop9
A#0	2149	Sd Garg L
B0	1621	Bd T8-3
C1	1612	Bd T9-1
C#1	2170	Sd HipHop Rim3
D1	2166	Sd HipHop10
D#1	1493	HipHop clap6
E1	2159	Sd HipHop1
F1	2451	Tom T8
F#1	2326	HH Closed T8-1
G1	2451	Tom T8
G#1	2327	HH Open T8-1
A1	2451	Tom T8
A#1	2327	HH Open T8-1
B1	2451	Tom T8
C2	2451	Tom T8
C#2	2466	Crash4
D2	2451	Tom T8
D#2	2499	Ride Brush1 R
E2	2522	Crash T8
F2	2524	Ride T9
F#2	1479	Tambourine RX5
G2	2519	Splash R
G#2	1465	Mambo Body
A2	2521	Crash T9
A#2	1451	Vibraslap
B2	2524	Ride T9
C3	1363	Bongo Hi 1Finger 1-2
C#3	1376	Bongo Lo 3Finger 1-2
D3	1335	Conga Hi Tip
D#3	1339	Conga Hi Open 2
E3	1357	Tumba Open
F3	1381	Timbale Hi1-3
F#3	1385	Timbale Lo1-2
G3	1429	Agogo Hi
G#3	1430	Agogo Lo
A3	1399	Cabasa1-2
A#3	1397	Maracas Slur
B3	1452	Whistle
C4	1452	Whistle
C#4	1433	Guiro Short
D4	1432	Guiro Long
D#4	1449	Clave
E4	1450	Wood Block
F4	1450	Wood Block
F#4	1362	Cuica Hi
G4	1361	Cuica Lo
G#4	1455	Triangle Mute
A4	1454	Triangle Open
A#4	1406	Shaker 1
B4	1467	Sleigh Bell
C5	1468	Wind Chime
C#5	2030	Sd Hip Stick8
D5	2118	Sd Jungle3
D#5	1458	HandClap R
E5	2135	Sd Hip Rim5
F5	1312	Scratch H
F#5	1313	Scratch L
G5	1314	Scratch Down
G#5	1316	Scratch Hi R
A5	1319	Scratch Bd F
A#5	1331	Scratch Combi
B5	1324	Scratch Vo R
C6	1638	Bd Break2

PRE 11 Hip Hop Kit 2

Note	Wave Number	Wave Name
C0	1621	Bd T8-3
C#0	2109	Sd T8 Rim
D0	2127	Sd Hip1
D#0	1469	Clap T9
E0	2152	Sd Syn
F0	2044	Sd LiveRoll R
F#0	2024	Sd Hip Stick4
G0	2160	Sd HipHop2
G#0	2173	Sd HipHop Rim6
A0	1635	Bd Hip Deep
A#0	2125	Sd R&B1 Rim
B0	1639	Bd Break Heavy
C1	1635	Bd Hip Deep
C#1	2169	Sd HipHop Rim2
D1	2129	Sd Hip3
D#1	1456	HandClap St
E1	2157	Sd Lo-Fi
F1	2365	Tom Floor R
F#1	2344	HH Closed Lo-Fi
G1	2360	Tom Low L
G#1	2333	HH Closed Break
A1	2360	Tom Low L
A#1	2345	HH Open Lo-Fi
B1	2360	Tom Low L
C2	2352	Tom Hi L
C#2	2465	Crash3
D2	2352	Tom Hi L
D#2	2524	Ride T9
E2	2516	China2
F2	2510	Ride Cup Mono
F#2	1479	Tambourine RX5
G2	2465	Crash3
G#2	1475	Cowbell RX11
A2	2463	Crash2 R
A#2	1474	Cowbell T8
B2	2524	Ride T9
C3	1363	Bongo Hi 1Finger 1-2
C#3	1376	Bongo Lo 3Finger 1-2
D3	1335	Conga Hi Tip
D#3	1341	Conga Hi Slip Open
E3	1339	Conga Hi Open 2
F3	1157	Radio Noise
F#3	1157	Radio Noise
G3	1430	Agogo Lo
G#3	1430	Agogo Lo
A3	1400	Cabasa1
A#3	1483	MaracasT8
B3	1297	FxGun2
C4	1296	FxGun1
C#4	1326	Scratch Spin
D4	1325	Scratch Stop
D#4	1485	Clave T8
E4	1301	Door Squeak
F4	1292	Hi Q2
F#4	1319	Scratch Bd F
G4	1320	Scratch Bd R
G#4	1455	Triangle Mute
A4	1454	Triangle Open
A#4	1478	Analog Shaker
B4	1420	Tambourine1 Hit
C5	1468	Wind Chime
C#5	2115	Sd Human2
D5	2140	Sd Break Roll
D#5	1175	Stab Hard
E5	2116	Sd Jungle1
F5	1560	Bd Rock1 St
F#5	1314	Scratch Down
G5	861	Wataiko
G#5	1143	HH Hit
A5	1176	Stab Organ2
A#5	1169	Sonar1
B5	1299	TurnTable
C6	1300	Police

PRE 12 Hip Hop Kit 3

Note	Wave Number	Wave Name
C0	2109	Sd T8 Rim
C#0	1293	Vox Hit Rev
D0	1299	TurnTable
D#0	1175	Stab Hard
E0	1324	Scratch Vo R
F0	2045	Sd Roll Mono
F#0	1485	Clave T8
G0	1891	Sd Hip 1R
G#0	2024	Sd Hip Stick4
A0	1623	Bd AnCR
A#0	2133	Sd Hip Rim3
B0	1614	Bd T9-3
C1	1635	Bd Hip Deep
C#1	2025	Sd Hip Stick5
D1	2130	Sd Hip Gate
D#1	1493	HipHop clap6
E1	2157	Sd Lo-Fi
F1	2451	Tom T8
F#1	2341	HH Closed Hip
G1	2451	Tom T8
G#1	2342	HH Pedal Hip
A1	2451	Tom T8
A#1	2343	HH Open Hip
B1	2451	Tom T8
C2	2451	Tom T8
C#2	2466	Crash4
D2	2451	Tom T8
D#2	2491	Ride2 R
E2	2522	Crash T8
F2	2524	Ride T9
F#2	1479	Tambourine RX5
G2	2519	Splash R
G#2	1465	Mambo Body
A2	2521	Crash T9
A#2	1451	Vibraslap
B2	2524	Ride T9
C3	1363	Bongo Hi 1Finger 1-2
C#3	1376	Bongo Lo 3Finger 1-2
D3	1335	Conga Hi Tip
D#3	1341	Conga Hi Slip Open
E3	1339	Conga Hi Open 2
F3	1381	Timbale Hi1-3
F#3	1385	Timbale Lo1-2
G3	1429	Agogo Hi
G#3	1430	Agogo Lo
A3	1409	Shaker Hip1
A#3	1397	Maracas Slur
B3	1452	Whistle
C4	1452	Whistle
C#4	1433	Guiro Short
D4	1432	Guiro Long
D#4	1449	Clave
E4	1450	Wood Block
F4	1450	Wood Block
F#4	1362	Cuica Hi
G4	1361	Cuica Lo
G#4	1455	Triangle Mute
A4	1454	Triangle Open
A#4	1406	Shaker 1
B4	1467	Sleigh Bell
C5	1468	Wind Chime
C#5	2021	Sd Hip Stick1
D5	2116	Sd Jungle1
D#5	1458	HandClap R
E5	2139	Sd Break Heavy
F5	1313	Scratch L
F#5	1314	Scratch Down
G5	1315	Scratch Hi F
G#5	1317	Scratch Lo F
A5	1318	Scratch Lo R
A#5	1319	Scratch Bd F
B5	1320	Scratch Bd R
C6	1639	Bd Break Heavy

PRE 13 Hip Hop Kit 5

Note	Wave Number	Wave Name
C0	2021	Sd Hip Stick1
C#0	1291	Hi Q1
D0	1299	TurnTable
D#0	1178	Hit Uhh
E0	1325	Scratch Stop
F0	2043	Sd LiveRoll L
F#0	1485	Clave T8
G0	2147	Sd Cut
G#0	2017	Sd Rock Stick1 R
A0	1613	Bd T9-2
A#0	2131	Sd Hip Rim1
B0	1634	Bd R&B2
C1	1636	Bd Break Deep
C#1	2035	Sd Closed Rim3
D1	2132	Sd Hip Rim2
D#1	1491	HipHop clap4
E1	2124	Sd R&B1
F1	1473	Conga T8
F#1	2326	HH Closed T8-1
G1	1473	Conga T8
G#1	2328	HH Closed T8-2
A1	1473	Conga T8
A#1	2329	HH Open T8-2
B1	1473	Conga T8
C2	1473	Conga T8
C#2	2466	Crash4
D2	1473	Conga T8
D#2	2491	Ride2 R
E2	2522	Crash T8
F2	2524	Ride T9
F#2	1479	Tambourine RX5
G2	2519	Splash R
G#2	1465	Mambo Body
A2	2521	Crash T9
A#2	1451	Vibraslap
B2	2524	Ride T9
C3	1363	Bongo Hi 1Finger 1-2
C#3	1376	Bongo Lo 3Finger 1-2
D3	1335	Conga Hi Tip
D#3	1339	Conga Hi Open 2
E3	1357	Tumba Open
F3	1381	Timbale Hi1-3
F#3	1385	Timbale Lo1-2
G3	1429	Agogo Hi
G#3	1430	Agogo Lo
A3	1399	Cabasa1-2
A#3	1397	Maracas Slur
B3	1452	Whistle
C4	1452	Whistle
C#4	1433	Guiro Short
D4	1432	Guiro Long
D#4	1449	Clave
E4	1450	Wood Block
F4	1450	Wood Block
F#4	1362	Cuica Hi
G4	1361	Cuica Lo
G#4	1455	Triangle Mute
A4	1454	Triangle Open
A#4	1406	Shaker 1
B4	1467	Sleigh Bell
C5	1468	Wind Chime
C#5	2033	Sd Closed Rim R
D5	2111	Sd AnSm Rim
D#5	1456	HandClap St
E5	2129	Sd Hip3
F5	1322	Scratch Sd R
F#5	1327	Scratch Hip
G5	1320	Scratch Bd R
G#5	1324	Scratch Vo R
A5	1328	Scratch Hip2
A#5	1332	Scratch Combi2
B5	1334	Scratch Combi4
C6	1635	Bd Hip Deep

PRE 14 Hip Stick Kit 1

Note	Wave Number	Wave Name
C0	2134	Sd Hip Rim4
C#0	1291	Hi Q1
D0	1299	TurnTable
D#0	1171	Hit Orchestra1
E0	1320	Scratch Bd R
F0	2044	Sd LiveRoll R
F#0	1487	Analog Click
G0	2133	Sd Hip Rim3
G#0	2113	Sd AnCR Rim
A0	1680	Bd HipHop9
A#0	2173	Sd HipHop Rim6
B0	1621	Bd T8-3
C1	1620	Bd T8-2
C#1	2109	Sd T8 Rim
D1	2024	Sd Hip Stick4
D#1	1458	HandClap R
E1	2023	Sd Hip Stick3
F1	2451	Tom T8
F#1	2326	HH Closed T8-1
G1	2451	Tom T8
G#1	2327	HH Open T8-1
A1	2451	Tom T8
A#1	2327	HH Open T8-1
B1	2451	Tom T8
C2	2451	Tom T8
C#2	2466	Crash4
D2	2451	Tom T8
D#2	2491	Ride2 R
E2	2522	Crash T8
F2	2524	Ride T9
F#2	1479	Tambourine RX5
G2	2519	Splash R
G#2	1465	Mambo Body
A2	2521	Crash T9
A#2	1451	Vibraslap
B2	2524	Ride T9
C3	1363	Bongo Hi 1Finger 1-2
C#3	1376	Bongo Lo 3Finger 1-2
D3	1335	Conga Hi Tip
D#3	1339	Conga Hi Open 2
E3	1357	Tumba Open
F3	1381	Timbale Hi1-3
F#3	1385	Timbale Lo1-2
G3	1429	Agogo Hi
G#3	1430	Agogo Lo
A3	1399	Cabasa1-2
A#3	1397	Maracas Slur
B3	1452	Whistle
C4	1452	Whistle
C#4	1433	Guiro Short
D4	1432	Guiro Long
D#4	1449	Clave
E4	1450	Wood Block
F4	1450	Wood Block
F#4	1362	Cuica Hi
G4	1361	Cuica Lo
G#4	1455	Triangle Mute
A4	1454	Triangle Open
A#4	1406	Shaker 1
B4	1467	Sleigh Bell
C5	1468	Wind Chime
C#5	2110	Sd AnSm
D5	2035	Sd Closed Rim3
D#5	1487	Analog Click
E5	2034	Sd Closed Rim2
F5	1312	Scratch H
F#5	1313	Scratch L
G5	1314	Scratch Down
G#5	1316	Scratch Hi R
A5	1319	Scratch Bd F
A#5	1331	Scratch Combi
B5	1324	Scratch Vo R
C6	1629	Bd Jungle2

PRE 15 Hip Stick Kit 2

Note	Wave Number	Wave Name
C0	2133	Sd Hip Rim3
C#0	1292	Hi Q2
D0	1312	Scratch H
D#0	1312	Scratch H
E0	1324	Scratch Vo R
F0	2045	Sd Roll Mono
F#0	1487	Analog Click
G0	2134	Sd Hip Rim4
G#0	2109	Sd T8 Rim
A0	1680	Bd HipHop9
A#0	2024	Sd Hip Stick4
B0	1653	Bd Hard Long
C1	1669	Bd ElecClick
C#1	2021	Sd Hip Stick1
D1	2022	Sd Hip Stick2
D#1	1495	HipHop clap8
E1	2026	Sd Hip Stick6 St
F1	2450	Tom T9 Lo
F#1	2326	HH Closed T8-1
G1	2450	Tom T9 Lo
G#1	2327	HH Open T8-1
A1	2450	Tom T9 Lo
A#1	2327	HH Open T8-1
B1	2450	Tom T9 Lo
C2	2450	Tom T9 Lo
C#2	2521	Crash T9
D2	2450	Tom T9 Lo
D#2	2488	Ride1 RL
E2	2522	Crash T8
F2	2511	Ride Cup Mono2
F#2	1482	Electric Tambourine2
G2	2519	Splash R
G#2	1474	Cowbell T8
A2	2521	Crash T9
A#2	1451	Vibraslap
B2	2523	Crash Syn
C3	1363	Bongo Hi 1Finger 1-2
C#3	1376	Bongo Lo 3Finger 1-2
D3	1335	Conga Hi Tip
D#3	1339	Conga Hi Open 2
E3	1357	Tumba Open
F3	1381	Timbale Hi1-3
F#3	1385	Timbale Lo1-2
G3	1429	Agogo Hi
G#3	1430	Agogo Lo
A3	1399	Cabasa1-2
A#3	1397	Maracas Slur
B3	1452	Whistle
C4	1452	Whistle
C#4	1433	Guiro Short
D4	1432	Guiro Long
D#4	1449	Clave
E4	1450	Wood Block
F4	1450	Wood Block
F#4	1362	Cuica Hi
G4	1361	Cuica Lo
G#4	1455	Triangle Mute
A4	1454	Triangle Open
A#4	1406	Shaker 1
B4	1467	Sleigh Bell
C5	1468	Wind Chime
C#5	2109	Sd T8 Rim
D5	2021	Sd Hip Stick1
D#5	2022	Sd Hip Stick2
E5	2034	Sd Closed Rim2
F5	1314	Scratch Down
F#5	1315	Scratch Hi F
G5	1317	Scratch Lo F
G#5	1318	Scratch Lo R
A5	1320	Scratch Bd R
A#5	1331	Scratch Combi
B5	1325	Scratch Stop
C6	1679	Bd HipHop8

PRE 16 R&B Kit 1

Note	Wave Number	Wave Name
C0	1618	Bd T9 Hd3
C#0	2112	Sd AnCR
D0	2111	Sd AnSm Rim
D#0	2145	Sd ClapAna
E0	2102	Sd T9Gate
F0	2045	Sd Roll Mono
F#0	2154	Sd Timbr
G0	2151	Sd FM Rim
G#0	2119	Sd JungleFX
A0	1615	Bd T9-4
A#0	2135	Sd Hip Rim5
B0	1614	Bd T9-3
C1	1660	Bd Elec2
C#1	2109	Sd T8 Rim
D1	2157	Sd Lo-Fi
D#1	1489	HipHop clap2
E1	2124	Sd R&B1
F1	1621	Bd T8-3
F#1	2324	HH Closed T9
G1	1621	Bd T8-3
G#1	2342	HH Pedal Hip
A1	1621	Bd T8-3
A#1	2325	HH Open T9
B1	1621	Bd T8-3
C2	1621	Bd T8-3
C#2	2460	Crash1 RL
D2	1621	Bd T8-3
D#2	2489	Ride2 St
E2	2516	China2
F2	2510	Ride Cup Mono
F#2	1420	Tambourine1 Hit
G2	2465	Crash3
G#2	1461	Cowbell1
A2	2457	Crash1 St
A#2	1474	Cowbell T8
B2	2485	Ride1 St
C3	1363	Bongo Hi 1Finger 1-2
C#3	1376	Bongo Lo 3Finger 1-2
D3	1335	Conga Hi Tip
D#3	1341	Conga Hi Slip Open
E3	1339	Conga Hi Open 2
F3	1291	Hi Q1
F#3	1291	Hi Q1
G3	1430	Agogo Lo
G#3	1430	Agogo Lo
A3	1478	Analog Shaker
A#3	1397	Maracas Slur
B3	1180	Vox Drum
C4	1180	Vox Drum
C#4	1291	Hi Q1
D4	1292	Hi Q2
D#4	1485	Clave T8
E4	1291	Hi Q1
F4	1326	Scratch Spin
F#4	1316	Scratch Hi R
G4	1315	Scratch Hi F
G#4	1455	Triangle Mute
A4	1454	Triangle Open
A#4	1407	Shaker 2
B4	1420	Tambourine1 Hit
C5	1468	Wind Chime
C#5	2140	Sd Break Roll
D5	1273	Noise Burst
D#5	1134	Vox Bell
E5	2124	Sd R&B1
F5	1144	VoxAlk
F#5	886	Udo High
G5	1139	Trance Choir
G#5	1154	Swarm
A5	1568	Bd Pop
A#5	2125	Sd R&B1 Rim
B5	1634	Bd R&B2
C6	2465	Crash3

PRE 17 R&B Kit 2

Note	Wave Number	Wave Name
C0	1612	Bd T9-1
C#0	2113	Sd AnCR Rim
D0	2130	Sd Hip Gate
D#0	2140	Sd Break Roll
E0	2098	Sd T9-2
F0	2042	Sd LiveRoll St
F#0	1499	HipHop Snap2
G0	2165	Sd HipHop9
G#0	2169	Sd HipHop Rim2
A0	1676	Bd HipHop5
A#0	2134	Sd Hip Rim4
B0	1612	Bd T9-1
C1	1620	Bd T8-2
C#1	2168	Sd HipHop Rim1
D1	1499	HipHop Snap2
D#1	1495	HipHop clap8
E1	2108	Sd T8-5
F1	2451	Tom T8
F#1	2326	HH Closed T8-1
G1	2451	Tom T8
G#1	2327	HH Open T8-1
A1	2451	Tom T8
A#1	2327	HH Open T8-1
B1	2451	Tom T8
C2	2451	Tom T8
C#2	2460	Crash1 RL
D2	2451	Tom T8
D#2	2489	Ride2 St
E2	2516	China2
F2	2510	Ride Cup Mono
F#2	1420	Tambourine1 Hit
G2	2465	Crash3
G#2	1461	Cowbell1
A2	2457	Crash1 St
A#2	1474	Cowbell T8
B2	2485	Ride1 St
C3	1363	Bongo Hi 1Finger 1-2
C#3	1376	Bongo Lo 3Finger 1-2
D3	1335	Conga Hi Tip
D#3	1341	Conga Hi Slp Open
E3	1339	Conga Hi Open 2
F3	1291	Hi Q1
F#3	1291	Hi Q1
G3	1430	Agogo Lo
G#3	1430	Agogo Lo
A3	1478	Analog Shaker
A#3	1397	Maracas Slur
B3	1180	Vox Drum
C4	1180	Vox Drum
C#4	1291	Hi Q1
D4	1292	Hi Q2
D#4	1485	Clave T8
E4	1291	Hi Q1
F4	1326	Scratch Spin
F#4	1316	Scratch Hi R
G4	1315	Scratch Hi F
G#4	1455	Triangle Mute
A4	1454	Triangle Open
A#4	1407	Shaker 2
B4	1420	Tambourine1 Hit
C5	1468	Wind Chime
C#5	2140	Sd Break Roll
D5	1273	Noise Burst
D#5	1134	Vox Bell
E5	2124	Sd R&B1
F5	1144	VoxAlk
F#5	886	Udo High
G5	1139	Trance Choir
G#5	1154	Swarm
A5	1568	Bd Pop
A#5	2125	Sd R&B1 Rim
B5	1634	Bd R&B2
C6	2465	Crash3

PRE 18 R&B Kit 3

Note	Wave Number	Wave Name
C0	1617	Bd T9 Hd2
C#0	2112	Sd AnCR
D0	2137	Sd Break2
D#0	2140	Sd Break Roll
E0	2102	Sd T9Gate
F0	2045	Sd Roll Mono
F#0	1499	HipHop Snap2
G0	2160	Sd HipHop2
G#0	2170	Sd HipHop Rim3
A0	1613	Bd T9-2
A#0	2133	Sd Hip Rim3
B0	1612	Bd T9-1
C1	1620	Bd T8-2
C#1	2170	Sd HipHop Rim3
D1	2124	Sd R&B1
D#1	1493	HipHop clap6
E1	2130	Sd Hip Gate
F1	2450	Tom T9 Lo
F#1	2324	HH Closed T9
G1	2450	Tom T9 Lo
G#1	2325	HH Open T9
A1	2450	Tom T9 Lo
A#1	2325	HH Open T9
B1	2450	Tom T9 Lo
C2	2449	Tom T9 Hi
C#2	2460	Crash1 RL
D2	1621	Bd T8-3
D#2	2489	Ride2 St
E2	2516	China2
F2	2510	Ride Cup Mono
F#2	1420	Tambourine1 Hit
G2	2465	Crash3
G#2	1461	Cowbell1
A2	2457	Crash1 St
A#2	1474	Cowbell T8
B2	2485	Ride1 St
C3	1363	Bongo Hi 1Finger 1-2
C#3	1376	Bongo Lo 3Finger 1-2
D3	1335	Conga Hi Tip
D#3	1341	Conga Hi Slp Open
E3	1339	Conga Hi Open 2
F3	1291	Hi Q1
F#3	1291	Hi Q1
G3	1430	Agogo Lo
G#3	1430	Agogo Lo
A3	1478	Analog Shaker
A#3	1397	Maracas Slur
B3	1180	Vox Drum
C4	1180	Vox Drum
C#4	1291	Hi Q1
D4	1292	Hi Q2
D#4	1485	Clave T8
E4	1291	Hi Q1
F4	1326	Scratch Spin
F#4	1316	Scratch Hi R
G4	1315	Scratch Hi F
G#4	1455	Triangle Mute
A4	1454	Triangle Open
A#4	1407	Shaker 2
B4	1420	Tambourine1 Hit
C5	1468	Wind Chime
C#5	2140	Sd Break Roll
D5	1273	Noise Burst
D#5	1134	Vox Bell
E5	2124	Sd R&B1
F5	1144	VoxAlk
F#5	886	Udo High
G5	1139	Trance Choir
G#5	1154	Swarm
A5	1568	Bd Pop
A#5	2125	Sd R&B1 Rim
B5	1634	Bd R&B2
C6	2465	Crash3

PRE 19 Trance Kit

Note	Wave Number	Wave Name
C0	1613	Bd T9-2
C#0	2111	Sd AnSm Rim
D0	2093	Sd Elec9
D#0	1470	Clap AnSm
E0	2091	Sd Elec7
F0	2095	Sd Elec11
F#0	2091	Sd Elec7
G0	2104	Sd T8-1
G#0	2101	Sd T9-5
A0	1617	Bd T9 Hd2
A#0	2096	Sd Elec12
B0	1618	Bd T9 Hd3
C1	1653	Bd Hard Long
C#1	2103	Sd T9Rim
D1	2089	Sd Elec5
D#1	1469	Clap T9
E1	2098	Sd T9-2
F1	2152	Sd Syn
F#1	2324	HH Closed T9
G1	2152	Sd Syn
G#1	2325	HH Open T9
A1	2152	Sd Syn
A#1	2325	HH Open T9
B1	2152	Sd Syn
C2	2152	Sd Syn
C#2	2521	Crash T9
D2	2152	Sd Syn
D#2	2524	Ride T9
E2	2523	Crash Syn
F2	2510	Ride Cup Mono
F#2	1420	Tambourine1 Hit
G2	2522	Crash T8
G#2	1474	Cowbell T8
A2	2512	China St
A#2	1474	Cowbell T8
B2	2485	Ride1 St
C3	1363	Bongo Hi 1Finger 1-2
C#3	1376	Bongo Lo 3Finger 1-2
D3	1342	Conga Hi Slap
D#3	1341	Conga Hi Slp Open
E3	1339	Conga Hi Open 2
F3	2452	Tom Syn1
F#3	2452	Tom Syn1
G3	1487	Analog Click
G#3	1273	Noise Burst
A3	1401	Cabasa2
A#3	1397	Maracas Slur
B3	1203	Neo Seq Em-3
C4	1221	Neo Seq2 Em-5
C#4	1276	Electric Perc1
D4	1409	Shaker Hip1
D#4	1485	Clave T8
E4	1479	Tambourine RX5
F4	1475	Cowbell RX11
F#4	1410	Shaker Hip2
G4	1285	Electric Perc10
G#4	1455	Triangle Mute
A4	1454	Triangle Open
A#4	1412	Shaker Hip4
B4	1275	Zap2
C5	1679	Bd HipHop8
C#5	1616	Bd T9 Hd1
D5	1665	Bd ElecComp3
D#5	1612	Bd T9-1
E5	1618	Bd T9 Hd3
F5	1653	Bd Hard Long
F#5	2326	HH Closed T8-1
G5	1664	Bd ElecComp2
G#5	2329	HH Open T8-2
A5	1616	Bd T9 Hd1
A#5	2327	HH Open T8-1
B5	1617	Bd T9 Hd2
C6	1665	Bd ElecComp3

PRE 20 Psychedelic Kit

Note	Wave Number	Wave Name
C0	1166	LFO Seq
C#0	1139	Trance Choir
D0	903	Tibetan Bowl
D#0	1325	Scratch Stop
E0	1244	Fx Female Voice St
F0	1176	Stab Organ2
F#0	1301	Door Squeak
G0	1157	Radio Noise
G#0	1301	Door Squeak
A0	2644	Acoustic Bass FX06
A#0	2649	Electric Bass FX 02
B0	2644	Acoustic Bass FX06
C1	1627	Bd BlpHd
C#1	1626	Bd Blip
D1	2130	Sd Hip Gate
D#1	1815	Sd SonA St1-4
E1	1273	Noise Burst
F1	2456	Tom Dist Lo
F#1	2324	HH Closed T9
G1	2455	Tom Dist Hi
G#1	2176	HH Closed 2St
A1	2449	Tom T9 Hi
A#1	2325	HH Open T9
B1	2449	Tom T9 Hi
C2	2449	Tom T9 Hi
C#2	2512	China St
D2	2449	Tom T9 Hi
D#2	2517	Splash St
E2	2521	Crash T9
F2	2524	Ride T9
F#2	1424	Pandeiro Tip
G2	1481	Electric Tambourine1
G#2	1292	Hi Q2
A2	1610	Bd Gate
A#2	1292	Hi Q2
B2	2641	Acoustic Bass FX03
C3	2639	Acoustic Bass FX01
C#3	1022	Mini Blip6
D3	1017	Mini Blip1
D#3	1018	Mini Blip2
E3	1354	Quinto1 Slap
F3	866	Tabla Bya
F#3	862	Djembe Edge
G3	867	Tabla Nah
G#3	893	Barasim Tak
A3	1283	Electric Perc8
A#3	1288	Electric Perc13
B3	1167	Hop FX1
C4	1214	Motion Beam
C#4	1275	Zap2
D4	1259	Digi Voice Mod
D#4	821	Human Whistle
E4	1258	Digital Wind
F4	1487	Analog Click
F#4	2326	HH Closed T8-1
G4	2150	Sd FM
G#4	2229	HH Half Open2 RL
A4	1485	Clave T8
A#4	2327	HH Open T8-1
B4	2525	Reverse Cymbal
C5	1654	Bd Analog Tight
C#5	1665	Bd ElecComp3
D5	1618	Bd T9 Hd3
D#5	1649	Bd ZapHard
E5	1658	Bd Slimy
F5	1640	Bd Break Hard
F#5	2011	Sd BreakRim
G5	1703	Sd Soul St1-3
G#5	1920	Sd Ambience
A5	1899	Sd Rock Mute1 R
A#5	2147	Sd Cut
B5	2122	Sd D&B3
C6	2141	Sd FX1

PRE 21 Chill Out Kit 2

Note	Wave Number	Wave Name
C0	1619	Bd T8-1
C#0	2109	Sd T8 Rim
D0	2105	Sd T8-2
D#0	1471	Electric Clap1
E0	2095	Sd Elec11
F0	2091	Sd Elec7
F#0	2107	Sd T8-4
G0	1660	Bd Elec2
G#0	2104	Sd T8-1
A0	1679	Bd HipHop8
A#0	2106	Sd T8-3
B0	1680	Bd HipHop9
C1	1679	Bd HipHop8
C#1	2111	Sd AnSm Rim
D1	2162	Sd HipHop5
D#1	1470	Clap AnSm
E1	2163	Sd HipHop6
F1	2451	Tom T8
F#1	2326	HH Closed T8-1
G1	2451	Tom T8
G#1	2327	HH Open T8-1
A1	2451	Tom T8
A#1	2327	HH Open T8-1
B1	2451	Tom T8
C2	2451	Tom T8
C#2	2465	Crash3
D2	2451	Tom T8
D#2	2524	Ride T9
E2	2517	Splash St
F2	2510	Ride Cup Mono
F#2	1420	Tambourine1 Hit
G2	2522	Crash T8
G#2	1474	Cowbell T8
A2	2512	China St
A#2	1474	Cowbell T8
B2	2485	Ride1 St
C3	1473	Conga T8
C#3	1473	Conga T8
D3	1473	Conga T8
D#3	1473	Conga T8
E3	1473	Conga T8
F3	1342	Conga Hi Slap
F#3	1341	Conga Hi Slp Open
G3	1339	Conga Hi Open 2
G#3	1382	Timbale Hi1
A3	1401	Cabasa2
A#3	1397	Maracas Slur
B3	1244	Fx Female Voice St
C4	1225	Portamento Lead Seq
C#4	1284	Electric Perc9
D4	1409	Shaker Hip1
D#4	1485	Clave T8
E4	1291	Hi Q1
F4	1292	Hi Q2
F#4	1410	Shaker Hip2
G4	1290	Electric Perc15
G#4	1455	Triangle Mute
A4	1454	Triangle Open
A#4	1412	Shaker Hip4
B4	1268	Ripper
C5	1662	Bd Elec4
C#5	2127	Sd Hip1
D5	2093	Sd Elec9
D#5	2090	Sd Elec6
E5	2160	Sd HipHop2
F5	1668	Bd ElecGate
F#5	2328	HH Closed T8-2
G5	1657	Bd ThickSkin
G#5	2329	HH Open T8-2
A5	1639	Bd Break Heavy
A#5	2329	HH Open T8-2
B5	1636	Bd Break Deep
C6	1634	Bd R&B2

PRE 22 Brush Kit

Note	Wave Number	Wave Name
C0	1449	Clave
C#0	2046	Sd Brush Soft St
D0	2058	Sd Brush Swir St
D#0	2049	Sd Brush Med St
E0	2061	Sd Brush SwirAtt St
F0	2042	Sd LiveRoll St
F#0	1448	Castanet
G0	2046	Sd Brush Soft St
G#0	1446	Stick1
A0	1536	Bd Funk St1-2
A#0	1806	Sd Basic 3St
B0	1574	Bd Jazz1-2St
C1	1583	Bd FK Jazz St
C#1	2055	Sd Closed Rim4 St
D1	2049	Sd Brush Med St
D#1	1456	HandClap St
E1	2052	Sd Brush vari St
F1	2439	Tom Brush floor St
F#1	2273	HH Power ClTip 1-4St
G1	2435	Tom Brush Low St
G#1	2313	HH Power ClPedal St
A1	2435	Tom Brush Low St
A#1	2317	HH Power Open EdgeSt
B1	2431	Tom Brush Mid St
C2	2431	Tom Brush Mid St
C#2	2467	Crash Brush1 St
D2	2427	Tom Brush Hi St
D#2	2497	Ride Brush1 St
E2	2512	China St
F2	2471	Crash Brush Cup St
F#2	1419	Tambourine1 Sw
G2	2517	Splash St
G#2	1462	Cowbell2
A2	2475	Crash Brush2 St
A#2	1451	Vibraslap
B2	2501	Ride Brush2 St
C3	1363	Bongo Hi 1Finger 1-2
C#3	1373	Bongo Lo 1Finger 1-2
D3	1343	Conga Hi SlapMute1-2
D#3	1337	Conga Hi Open 1-2
E3	1348	Conga Lo Open 1-2
F3	1381	Timbale Hi1-3
F#3	1385	Timbale Lo1-2
G3	1429	Agogo Hi
G#3	1430	Agogo Lo
A3	1399	Cabasa1-2
A#3	1397	Maracas Slur
B3	1452	Whistle
C4	1452	Whistle
C#4	1433	Guiro Short
D4	1432	Guiro Long
D#4	1449	Clave
E4	1450	Wood Block
F4	1450	Wood Block
F#4	1362	Cuica Hi
G4	1361	Cuica Lo
G#4	1455	Triangle Mute
A4	1454	Triangle Open
A#4	1405	Shaker 1/3
B4	1467	Sleigh Bell
C5	1468	Wind Chime
C#5	1682	Sd Bld St1-4
D5	1841	Sd Blues 3St
D#5	1885	Sd Hip St1-2
E5	1782	Sd Funk St1-3
F5	1702	Sd Soul St1-4
F#5	2010	Sd LdwHMMono
G5	2013	Sd Heavy
G#5	1865	Sd Tight St1-4
A5	1850	Sd BluesHeart St1-3
A#5	1500	Bd Snap 1-2
B5	1509	Bd Tight 1-2
C6	1536	Bd Funk St1-2

PRE 23 Jazz Kit

Note	Wave Number	Wave Name
C0	1574	Bd Jazz1-2St
C#0	2048	Sd Brush Soft R
D0	2061	Sd Brush SwirAtt St
D#0	2049	Sd Brush Med St
E0	2061	Sd Brush SwirAtt St
F0	2042	Sd LiveRoll St
F#0	1448	Castanet
G0	1886	Sd Hip 1St
G#0	1446	Stick1
A0	1541	Bd Funk 1 L
A#0	1873	Sd Tight 3St
B0	1583	Bd FK Jazz St
C1	1536	Bd Funk St1-2
C#1	2031	Sd Closed Rim St
D1	1871	Sd Tight 1St
D#1	2036	Sd RockRoll St
E1	1850	Sd BluesHeart St1-3
F1	2363	Tom Floor St
F#1	2273	HH Power ClTip 1-4St
G1	2363	Tom Floor St
G#1	2313	HH Power ClPedal St
A1	2359	Tom Low St
A#1	2317	HH Power Open EdgeSt
B1	2355	Tom Mid St
C2	2355	Tom Mid St
C#2	2461	Crash2 St
D2	2351	Tom Hi St
D#2	2489	Ride2 St
E2	2512	China St
F2	2511	Ride Cup Mono2
F#2	1420	Tambourine1 Hit
G2	2517	Splash St
G#2	1461	Cowbell1
A2	2461	Crash2 St
A#2	1451	Vibraslap
B2	2485	Ride1 St
C3	1363	Bongo Hi 1Finger 1-2
C#3	1376	Bongo Lo 3Finger 1-2
D3	1335	Conga Hi Tip
D#3	1341	Conga Hi Slp Open
E3	1339	Conga Hi Open 2
F3	1382	Timbale Hi1
F#3	1382	Timbale Hi1
G3	1430	Agogo Lo
G#3	1430	Agogo Lo
A3	1400	Cabasa1
A#3	1397	Maracas Slur
B3	2048	Sd Brush Soft R
C4	2058	Sd Brush Swir St
C#4	1433	Guiro Short
D4	1432	Guiro Long
D#4	1449	Clave
E4	1450	Wood Block
F4	1450	Wood Block
F#4	1389	Timbale Paila H
G4	1390	Timbale Paila L
G#4	1455	Triangle Mute
A4	1454	Triangle Open
A#4	1407	Shaker 2
B4	1467	Sleigh Bell
C5	1468	Wind Chime
C#5	1842	Sd Blues L1-3
D5	1797	Sd Funk Ay St
D#5	1858	Sd BluesHeart R1-3
E5	1836	Sd Blues St1-2
F5	1549	Bd Low L
F#5	2010	Sd LdwHMMono
G5	1567	Bd Dry2
G#5	2061	Sd Brush SwirAtt St
A5	1635	Bd Hip Deep
A#5	2045	Sd Roll Mono
B5	1535	Bd Normal 2R
C6	2475	Crash Brush2 St

PRE 24 Pop Latin Kit

Note	Wave Number	Wave Name
C0	1449	Clave
C#0	1441	Cajon Kick
D0	1442	Cajon Slap
D#0	1443	Cajon Tip 1-2
E0	1449	Clave
F0	1450	Wood Block
F#0	1456	HandClap St
G0	2490	Ride2 L
G#0	1499	HipHop Snap2
A0	1448	Castanet
A#0	1335	Conga Hi Tip
B0	1336	Conga Hi Heel
C1	1337	Conga Hi Open 1-2
C#1	1340	Conga Hi Mute
D1	1341	Conga Hi Slp Open
D#1	1342	Conga Hi Slap
E1	1343	Conga Hi SlapMute1-2
F1	1346	Conga Lo Tip
F#1	1347	Conga Lo Heel
G1	1348	Conga Lo Open 1-2
G#1	1351	Conga Lo Mute
A1	1352	Conga Lo SlapOpen
A#1	1352	Conga Lo SlapOpen
B1	1349	Conga Lo Open 1
C2	1363	Bongo Hi 1Finger 1-2
C#2	1366	Bongo Hi 3Finger 1-2
D2	1369	Bongo Hi Rim
D#2	1370	Bongo Hi Tip
E2	1371	Bongo Hi Heel
F2	1372	Bongo Hi Slap
F#2	1373	Bongo Lo 1Finger 1-2
G2	1376	Bongo Lo 3Finger 1-2
G#2	1379	Bongo Lo Rim
A2	1380	Bongo Lo Tip
A#2	1376	Bongo Lo 3Finger 1-2
B2	1372	Bongo Hi Slap
C3	1385	Timbale Lo1-2
C#3	1354	Quinto1 Slap
D3	1353	Quinto1 Open
D#3	1335	Conga Hi Tip
E3	1357	Tumba Open
F3	1391	Paila L
F#3	1381	Timbale Hi1-3
G3	1422	Pandeiro Open
G#3	1423	Pandeiro Thump
A3	1424	Pandeiro Tip
A#3	1425	Pandeiro Heel
B3	1392	Paila H
C4	1462	Cowbell2
C#4	1462	Cowbell2
D4	1429	Agogo Hi
D#4	1429	Agogo Hi
E4	1433	Guiro Short
F4	1432	Guiro Long
F#4	1435	MetalGuiro Short1-2
G4	1438	MetalGuiro Long
G#4	1419	Tambourine1 Sw
A4	1426	Tmbourim Open
A#4	1428	Tmbourim Mute
B4	1427	Tmbourim Finger
C5	1396	Maracas Sw
C#5	1405	Shaker 1/3
D5	1399	Cabasa 1-2
D#5	1361	Cuica Lo
E5	1362	Cuica Hi
F5	1461	Cowbell1
F#5	1465	Mambo Body
G5	1413	Shekere Down
G#5	1415	Shekere Sap
A5	1455	Triangle Mute
A#5	1454	Triangle Open
B5	1452	Whistle
C6	1468	Wind Chime

PRE 25 Analog T9 Kit

Note	Wave Number	Wave Name
C0	1613	Bd T9-2
C#0	2112	Sd AnCR
D0	2101	Sd T9-5
D#0	1470	Clap AnSm
E0	2102	Sd T9Gate
F0	2036	Sd RockRoll St
F#0	2099	Sd T9-3
G0	2100	Sd T9-4
G#0	2102	Sd T9Gate
A0	1615	Bd T9-4
A#0	2101	Sd T9-5
B0	1612	Bd T9-1
C1	1614	Bd T9-3
C#1	2103	Sd T9Rim
D1	2097	Sd T9-1
D#1	1469	Clap T9
E1	2098	Sd T9-2
F1	2450	Tom T9 Lo
F#1	2324	HH Closed T9
G1	2450	Tom T9 Lo
G#1	2325	HH Open T9
A1	2450	Tom T9 Lo
A#1	2325	HH Open T9
B1	2449	Tom T9 Hi
C2	2449	Tom T9 Hi
C#2	2521	Crash T9
D2	2449	Tom T9 Hi
D#2	2524	Ride T9
E2	2516	China2
F2	2510	Ride Cup Mono
F#2	1479	Tambourine RX5
G2	2465	Crash3
G#2	1461	Cowbell1
A2	2466	Crash4
A#2	1474	Cowbell T8
B2	2491	Ride2 R
C3	1473	Conga T8
C#3	1473	Conga T8
D3	1335	Conga Hi Tip
D#3	1341	Conga Hi Slp Open
E3	1339	Conga Hi Open 2
F3	1381	Timbale Hi1-3
F#3	1385	Timbale Lo1-2
G3	1487	Analog Click
G#3	1473	Conga T8
A3	1399	Cabasa1-2
A#3	1397	Maracas Slur
B3	1297	FxGun2
C4	1296	FxGun1
C#4	1312	Scratch H
D4	1314	Scratch Down
D#4	1291	Hi Q1
E4	1291	Hi Q1
F4	1292	Hi Q2
F#4	1313	Scratch L
G4	1313	Scratch L
G#4	1455	Triangle Mute
A4	1454	Triangle Open
A#4	1478	Analog Shaker
B4	1467	Sleigh Bell
C5	1468	Wind Chime
C#5	1915	Sd Piccolo
D5	2108	Sd T8-5
D#5	2039	Sd RockRollID St
E5	2049	Sd Brush Med St
F5	1627	Bd BlpHd
F#5	2116	Sd Jungle1
G5	1651	Bd Sustain
G#5	2120	Sd D&B1
A5	1638	Bd Break2
A#5	2146	Sd Dist
B5	1652	Bd TekPower
C6	1646	Bd Distortion RM

PRE 26 Analog T8 Kit

Note	Wave Number	Wave Name
C0	1619	Bd T8-1
C#0	2112	Sd AnCR
D0	2107	Sd T8-4
D#0	2145	Sd ClapAna
E0	2106	Sd T8-3
F0	2451	Tom T8
F#0	2108	Sd T8-5
G0	1621	Bd T8-3
G#0	2107	Sd T8-4
A0	1620	Bd T8-2
A#0	2106	Sd T8-3
B0	1009	T8 Kick Bass
C1	1620	Bd T8-2
C#1	2109	Sd T8 Rim
D1	2105	Sd T8-2
D#1	1469	Clap T9
E1	2104	Sd T8-1
F1	2451	Tom T8
F#1	2328	HH Closed T8-2
G1	2451	Tom T8
G#1	2327	HH Open T8-1
A1	2451	Tom T8
A#1	2327	HH Open T8-1
B1	2451	Tom T8
C2	2451	Tom T8
C#2	2522	Crash T8
D2	2451	Tom T8
D#2	2524	Ride T9
E2	2516	China2
F2	2510	Ride Cup Mono
F#2	1479	Tambourine RX5
G2	2519	Splash R
G#2	1474	Cowbell T8
A2	2466	Crash4
A#2	1451	Vibraslap
B2	2491	Ride2 R
C3	1473	Conga T8
C#3	1473	Conga T8
D3	1473	Conga T8
D#3	1473	Conga T8
E3	1473	Conga T8
F3	1382	Timbale Hi1
F#3	1386	Timbale Lo1
G3	1269	Glass
G#3	1269	Glass
A3	1399	Cabasa1-2
A#3	1483	MaracasT8
B3	1297	FxGun2
C4	1296	FxGun1
C#4	1478	Analog Shaker
D4	1478	Analog Shaker
D#4	1485	Clave T8
E4	1291	Hi Q1
F4	1292	Hi Q2
F#4	1313	Scratch L
G4	1313	Scratch L
G#4	1455	Triangle Mute
A4	1454	Triangle Open
A#4	1478	Analog Shaker
B4	1467	Sleigh Bell
C5	1468	Wind Chime
C#5	2127	Sd Hip1
D5	2128	Sd Hip2
D#5	2130	Sd Hip Gate
E5	2136	Sd Break1
F5	1626	Bd Blip
F#5	2141	Sd FX1
G5	1648	Bd FxHammer
G#5	2156	Sd Hammer
A5	1649	Bd ZapHard
A#5	2149	Sd Garg L
B5	1652	Bd TekPower
C6	1658	Bd Slimy

PRE 27 Tekno Kit

Note	Wave Number	Wave Name
C0	1658	Bd Slimy
C#0	2103	Sd T9Rim
D0	2108	Sd T8-5
D#0	1469	Clap T9
E0	2099	Sd T9-3
F0	2114	Sd Human1
F#0	2129	Sd Hip3
G0	2100	Sd T9-4
G#0	2128	Sd Hip2
A0	1657	Bd ThickSkin
A#0	2098	Sd T9-2
B0	1644	Bd Distortion4
C1	1650	Bd ZapMid
C#1	2109	Sd T8 Rim
D1	2108	Sd T8-5
D#1	1469	Clap T9
E1	2152	Sd Syn
F1	2451	Tom T8
F#1	2344	HH Closed Lo-Fi
G1	2451	Tom T8
G#1	2345	HH Open Lo-Fi
A1	2451	Tom T8
A#1	2345	HH Open Lo-Fi
B1	2451	Tom T8
C2	2451	Tom T8
C#2	2522	Crash T8
D2	2451	Tom T8
D#2	2524	Ride T9
E2	2465	Crash3
F2	2510	Ride Cup Mono
F#2	1480	Tambourine AnCR
G2	2462	Crash2 L
G#2	1474	Cowbell T8
A2	2521	Crash T9
A#2	1474	Cowbell T8
B2	2523	Crash Syn
C3	1473	Conga T8
C#3	1473	Conga T8
D3	1473	Conga T8
D#3	1473	Conga T8
E3	1473	Conga T8
F3	1381	Timbale Hi1-3
F#3	1385	Timbale Lo1-2
G3	1269	Glass
G#3	1269	Glass
A3	1400	Cabasa1
A#3	1483	MaracasT8
B3	1297	FxGun2
C4	1296	FxGun1
C#4	1312	Scratch H
D4	1314	Scratch Down
D#4	1291	Hi Q1
E4	1291	Hi Q1
F4	1292	Hi Q2
F#4	1313	Scratch L
G4	1313	Scratch L
G#4	1455	Triangle Mute
A4	1454	Triangle Open
A#4	1478	Analog Shaker
B4	1467	Sleigh Bell
C5	1662	Bd Elec4
C#5	1665	Bd ElecComp3
D5	1667	Bd ElecFX2
D#5	1669	Bd ElecClick
E5	1670	Bd ElecPower1
F5	1671	Bd ElecPower2
F#5	1661	Bd Elec3
G5	1659	Bd Elec1
G#5	2090	Sd Elec6
A5	2091	Sd Elec7
A#5	2092	Sd Elec8
B5	2093	Sd Elec9
C6	2096	Sd Elec12

PRE 28 House Kit 1

Note	Wave Number	Wave Name
C0	1615	Bd T9-4
C#0	2109	Sd T8 Rim
D0	2108	Sd T8-5
D#0	1456	HandClap St
E0	2149	Sd Garg L
F0	2042	Sd LiveRoll St
F#0	2099	Sd T9-3
G0	2104	Sd T8-1
G#0	2101	Sd T9-5
A0	1612	Bd T9-1
A#0	2102	Sd T9Gate
B0	1613	Bd T9-2
C1	1613	Bd T9-2
C#1	2103	Sd T9Rim
D1	2097	Sd T9-1
D#1	1469	Clap T9
E1	2098	Sd T9-2
F1	2450	Tom T9 Lo
F#1	2326	HH Closed T8-1
G1	2450	Tom T9 Lo
G#1	2325	HH Open T9
A1	2450	Tom T9 Lo
A#1	2325	HH Open T9
B1	2449	Tom T9 Hi
C2	2449	Tom T9 Hi
C#2	2521	Crash T9
D2	2449	Tom T9 Hi
D#2	2524	Ride T9
E2	2465	Crash3
F2	2510	Ride Cup Mono
F#2	1420	Tambourine 1 Hit
G2	2465	Crash3
G#2	1461	Cowbell1
A2	2461	Crash2 St
A#2	1474	Cowbell T8
B2	2485	Ride1 St
C3	1363	Bongo Hi 1Finger 1-2
C#3	1376	Bongo Lo 3Finger 1-2
D3	1335	Conga Hi Tip
D#3	1341	Conga Hi Slp Open
E3	1339	Conga Hi Open 2
F3	1382	Timbale Hi1
F#3	1382	Timbale Hi1
G3	1430	Agogo Lo
G#3	1430	Agogo Lo
A3	1400	Cabasa1
A#3	1397	Maracas Slur
B3	1180	Vox Drum
C4	1180	Vox Drum
C#4	1433	Guiro Short
D4	1432	Guiro Long
D#4	1449	Clave
E4	1450	Wood Block
F4	1450	Wood Block
F#4	1362	Cuica Hi
G4	1361	Cuica Lo
G#4	1455	Triangle Mute
A4	1454	Triangle Open
A#4	1478	Analog Shaker
B4	1467	Sleigh Bell
C5	1468	Wind Chime
C#5	2140	Sd Break Roll
D5	1273	Noise Burst
D#5	1134	Vox Bell
E5	2124	Sd R&B1
F5	1144	VoxAlk
F#5	886	Udo High
G5	1139	Trance Choir
G#5	1154	Swarm
A5	1568	Bd Pop
A#5	2125	Sd R&B1 Rim
B5	1634	Bd R&B2
C6	2465	Crash3

PRE 29 House Kit 2

Note	Wave Number	Wave Name
C0	1613	Bd T9-2
C#0	2109	Sd T8 Rim
D0	44	Brite Piano
D#0	1469	Clap T9
E0	2098	Sd T9-2
F0	2102	Sd T9Gate
F#0	2115	Sd Human2
G0	2141	Sd FX1
G#0	2157	Sd Lo-Fi
A0	1617	Bd T9 Hd2
A#0	2103	Sd T9Rim
B0	1614	Bd T9-3
C1	1616	Bd T9 Hd1
C#1	2103	Sd T9Rim
D1	2098	Sd T9-2
D#1	1273	Noise Burst
E1	1732	Sd Strong L1-4
F1	2152	Sd Syn
F#1	2324	HH Closed T9
G1	2152	Sd Syn
G#1	2325	HH Open T9
A1	2152	Sd Syn
A#1	2325	HH Open T9
B1	2152	Sd Syn
C2	2152	Sd Syn
C#2	2521	Crash T9
D2	2152	Sd Syn
D#2	2524	Ride T9
E2	2523	Crash Syn
F2	2510	Ride Cup Mono
F#2	1420	Tambourine1 Hit
G2	2522	Crash T8
G#2	1461	Cowbell1
A2	2465	Crash3
A#2	1474	Cowbell T8
B2	2485	Ride1 St
C3	1363	Bongo Hi 1Finger 1-2
C#3	1376	Bongo Lo 3Finger 1-2
D3	1336	Conga Hi Heel
D#3	1341	Conga Hi Slp Open
E3	1339	Conga Hi Open 2
F3	2452	Tom Syn1
F#3	2452	Tom Syn1
G3	1487	Analog Click
G#3	2158	Sd Rim SE
A3	1400	Cabasa1
A#3	1397	Maracas Slur
B3	1180	Vox Drum
C4	1180	Vox Drum
C#4	1480	Tambourine AnCR
D4	1478	Analog Shaker
D#4	1485	Clave T8
E4	1479	Tambourine RX5
F4	1475	Cowbell RX11
F#4	1478	Analog Shaker
G4	1315	Scratch Hi F
G#4	1455	Triangle Mute
A4	1454	Triangle Open
A#4	1478	Analog Shaker
B4	1467	Sleigh Bell
C5	1468	Wind Chime
C#5	866	Tabla Bya
D5	867	Tabla Nah
D#5	868	Tabla Mute
E5	1134	Vox Bell
F5	1568	Bd Pop
F#5	886	Udo High
G5	1611	Bd FX Gate
G#5	1273	Noise Burst
A5	1612	Bd T9-1
A#5	2140	Sd Break Roll
B5	2465	Crash3
C6	1299	TurnTable

PRE 30 House Compressed Kit

Note	Wave Number	Wave Name
C0	1615	Bd T9-4
C#0	2109	Sd T8 Rim
D0	2108	Sd T8-5
D#0	1456	HandClap St
E0	2149	Sd Garg L
F0	2042	Sd LiveRoll St
F#0	2099	Sd T9-3
G0	2104	Sd T8-1
G#0	2101	Sd T9-5
A0	1612	Bd T9-1
A#0	2102	Sd T9Gate
B0	1613	Bd T9-2
C1	1614	Bd T9-3
C#1	2103	Sd T9Rim
D1	2097	Sd T9-1
D#1	1469	Clap T9
E1	2098	Sd T9-2
F1	2450	Tom T9 Lo
F#1	2326	HH Closed T8-1
G1	2450	Tom T9 Lo
G#1	2325	HH Open T9
A1	2450	Tom T9 Lo
A#1	2325	HH Open T9
B1	2449	Tom T9 Hi
C2	2449	Tom T9 Hi
C#2	2521	Crash T9
D2	2449	Tom T9 Hi
D#2	2524	Ride T9
E2	2465	Crash3
F2	2510	Ride Cup Mono
F#2	1420	Tambourine1 Hit
G2	2465	Crash3
G#2	1461	Cowbell1
A2	2461	Crash2 St
A#2	1474	Cowbell T8
B2	2485	Ride1 St
C3	1363	Bongo Hi 1Finger 1-2
C#3	1376	Bongo Lo 3Finger 1-2
D3	1335	Conga Hi Tip
D#3	1341	Conga Hi Slp Open
E3	1339	Conga Hi Open 2
F3	1382	Timbale Hi1
F#3	1382	Timbale Hi1
G3	1430	Agogo Lo
G#3	1430	Agogo Lo
A3	1400	Cabasa1
A#3	1397	Maracas Slur
B3	1180	Vox Drum
C4	1180	Vox Drum
C#4	1433	Guiro Short
D4	1432	Guiro Long
D#4	1449	Clave
E4	1450	Wood Block
F4	1450	Wood Block
F#4	1362	Cuica Hi
G4	1361	Cuica Lo
G#4	1455	Triangle Mute
A4	1454	Triangle Open
A#4	1478	Analog Shaker
B4	1467	Sleigh Bell
C5	1468	Wind Chime
C#5	2140	Sd Break Roll
D5	1273	Noise Burst
D#5	1134	Vox Bell
E5	2124	Sd R&B1
F5	1144	VoxAlk
F#5	886	Udo High
G5	1139	Trance Choir
G#5	1154	Swarm
A5	1568	Bd Pop
A#5	2125	Sd R&B1 Rim
B5	1634	Bd R&B2
C6	2465	Crash3

PRE 31 Big Kit

Note	Wave Number	Wave Name
C0	1611	Bd FX Gate
C#0	1376	Bongo Lo 3Finger 1-2
D0	2014	Sd GM
D#0	1456	HandClap St
E0	2009	Sd Gate2
F0	2036	Sd RockRoll St
F#0	1900	Sd Rock Rim1 St
G0	1915	Sd Piccolo
G#0	1912	Sd Rock Flam St
A0	1572	Bd Room2
A#0	2015	Sd Rock Stick1 St
B0	1573	Bd Room3
C1	1610	Bd Gate
C#1	1919	Sd Mid Rim
D1	2008	Sd Gate1
D#1	1470	Clap AnSm
E1	1920	Sd Ambience
F1	2448	Tom Ambience Lo
F#1	2335	HH Closed D&B
G1	2448	Tom Ambience Lo
G#1	2336	HH Pedal D&B
A1	2448	Tom Ambience Lo
A#1	2337	HH Open D&B
B1	2447	Tom Ambience Hi
C2	2447	Tom Ambience Hi
C#2	2461	Crash2 St
D2	2447	Tom Ambience Hi
D#2	2485	Ride1 St
E2	2512	China St
F2	2510	Ride Cup Mono
F#2	1420	Tambourine1 Hit
G2	2465	Crash3
G#2	1461	Cowbell1
A2	2461	Crash2 St
A#2	1451	Vibraslap
B2	2485	Ride1 St
C3	1363	Bongo Hi 1Finger 1-2
C#3	1376	Bongo Lo 3Finger 1-2
D3	1335	Conga Hi Tip
D#3	1341	Conga Hi Slp Open
E3	1339	Conga Hi Open 2
F3	1647	Bd +HH
F#3	1647	Bd +HH
G3	1430	Agogo Lo
G#3	1430	Agogo Lo
A3	1400	Cabasa1
A#3	1397	Maracas Slur
B3	1297	FxGun2
C4	1296	FxGun1
C#4	1312	Scratch H
D4	1314	Scratch Down
D#4	1449	Clave
E4	1450	Wood Block
F4	1450	Wood Block
F#4	1313	Scratch L
G4	1313	Scratch L
G#4	1455	Triangle Mute
A4	1454	Triangle Open
A#4	1407	Shaker 2
B4	1467	Sleigh Bell
C5	1468	Wind Chime
C#5	2146	Sd Dist
D5	2150	Sd FM
D#5	2151	Sd FM Rim
E5	2153	Sd Clappy
F5	1573	Bd Room3
F#5	2154	Sd Timbr
G5	1560	Bd Rock1 St
G#5	2158	Sd Rim SE
A5	1563	Bd Rock2 St
A#5	2140	Sd Break Roll
B5	1631	Bd D&B1
C6	1572	Bd Room2

PRE 32 Break Kit

Note	Wave Number	Wave Name
C0	1636	Bd Break Deep
C#0	1886	Sd Hip 1St
D0	2157	Sd Lo-Fi
D#0	2153	Sd Clappy
E0	2010	Sd LdwHMono
F0	2039	Sd RockRollID St
F#0	2008	Sd Gate1
G0	1918	Sd Mid
G#0	2011	Sd BreakRim
A0	1639	Bd Break Heavy
A#0	2134	Sd Hip Rim4
B0	1638	Bd Break2
C1	1637	Bd Break1
C#1	2131	Sd Hip Rim1
D1	2138	Sd Break3
D#1	2136	Sd Break1
E1	2137	Sd Break2
F1	2359	Tom Low St
F#1	2243	HH Closed Rock S R
G1	2359	Tom Low St
G#1	2256	HH Pedal Rock R
A1	2359	Tom Low St
A#1	2268	HH Half Open Rock R
B1	2351	Tom Hi St
C2	2351	Tom Hi St
C#2	2462	Crash2 L
D2	2351	Tom Hi St
D#2	2490	Ride2 L
E2	2513	China L
F2	2510	Ride Cup Mono
F#2	1420	Tambourine1 Hit
G2	2465	Crash3
G#2	1461	Cowbell1
A2	2463	Crash2 R
A#2	1475	Cowbell RX11
B2	2509	Ride Mono
C3	1363	Bongo Hi 1Finger 1-2
C#3	1376	Bongo Lo 3Finger 1-2
D3	1335	Conga Hi Tip
D#3	1341	Conga Hi Slp Open
E3	1339	Conga Hi Open 2
F3	1363	Bongo Hi 1Finger 1-2
F#3	1376	Bongo Lo 3Finger 1-2
G3	1339	Conga Hi Open 2
G#3	1430	Agogo Lo
A3	1400	Cabasa1
A#3	1397	Maracas Slur
B3	1382	Timbale Hi1
C4	1386	Timbale Lo1
C#4	1312	Scratch H
D4	1314	Scratch Down
D#4	1449	Clave
E4	1450	Wood Block
F4	1450	Wood Block
F#4	1313	Scratch L
G4	1313	Scratch L
G#4	1455	Triangle Mute
A4	1454	Triangle Open
A#4	1407	Shaker 2
B4	1467	Sleigh Bell
C5	1299	TurnTable
C#5	2140	Sd Break Roll
D5	1015	FM Bass5
D#5	1161	Mind Bell
E5	2141	Sd FX1
F5	1563	Bd Rock2 St
F#5	1166	LFO Seq
G5	1268	Ripper
G#5	1273	Noise Burst
A5	1300	Police
A#5	1159	Fairwave
B5	1154	Swarm
C6	1157	Radio Noise

PRE 33 Drum'n'Bass Kit

Note	Wave Number	Wave Name
C0	1635	Bd Hip Deep
C#0	1376	Bongo Lo 3Finger 1-2
D0	2126	Sd R&B2
D#0	2154	Sd Timbr
E0	2122	Sd D&B3
F0	2156	Sd Hammer
F#0	1269	Glass
G0	1632	Bd D&B2
G#0	2197	HH Pedal 3 St
A0	1635	Bd Hip Deep
A#0	2230	HH Open2 St
B0	1640	Bd Break Hard
C1	1631	Bd D&B1
C#1	1919	Sd Mid Rim
D1	2120	Sd D&B1
D#1	1273	Noise Burst
E1	2121	Sd D&B2
F1	2448	Tom Ambience Lo
F#1	2335	HH Closed D&B
G1	2448	Tom Ambience Lo
G#1	2336	HH Pedal D&B
A1	2448	Tom Ambience Lo
A#1	2337	HH Open D&B
B1	2447	Tom Ambience Hi
C2	2447	Tom Ambience Hi
C#2	2462	Crash2 L
D2	2447	Tom Ambience Hi
D#2	2485	Ride1 St
E2	2516	China2
F2	2510	Ride Cup Mono
F#2	1420	Tambourine1 Hit
G2	2465	Crash3
G#2	1461	Cowbell1
A2	2461	Crash2 St
A#2	1451	Vibraslap
B2	2485	Ride1 St
C3	1363	Bongo Hi 1Finger 1-2
C#3	1376	Bongo Lo 3Finger 1-2
D3	1335	Conga Hi Tip
D#3	1341	Conga Hi Slp Open
E3	1339	Conga Hi Open 2
F3	2123	Sd D&B4
F#3	2338	HH Reverse D&B
G3	1430	Agogo Lo
G#3	1430	Agogo Lo
A3	1400	Cabasa1
A#3	1397	Maracas Slur
B3	1297	FxGun2
C4	1296	FxGun1
C#4	1433	Guiro Short
D4	1432	Guiro Long
D#4	1449	Clave
E4	1283	Electric Perc8
F4	1277	Electric Perc2
F#4	1042	P50-1
G4	1288	Electric Perc13
G#4	1299	TurnTable
A4	1454	Triangle Open
A#4	1407	Shaker 2
B4	1467	Sleigh Bell
C5	1468	Wind Chime
C#5	2146	Sd Dist
D5	2150	Sd FM
D#5	2151	Sd FM Rim
E5	2153	Sd Clappy
F5	1631	Bd D&B1
F#5	2154	Sd Timbr
G5	1645	Bd Distortion5
G#5	2158	Sd Rim SE
A5	1644	Bd Distortion4
A#5	2129	Sd Hip3
B5	1658	Bd Slimy
C6	1647	Bd +HH

PRE 34 Acid Kit

Note	Wave Number	Wave Name
C0	1654	Bd Analog Tight
C#0	2109	Sd T8 Rim
D0	2118	Sd Jungle3
D#0	1456	HandClap St
E0	2104	Sd T8-1
F0	2452	Tom Syn1
F#0	1857	Sd BluesHeart L1-3
G0	1864	Sd BluesHeart 3R
G#0	1816	Sd SonA St1-3
A0	1536	Bd Funk St1-2
A#0	1800	Sd Basic St1-3
B0	1626	Bd Blip
C1	1615	Bd T9-4
C#1	2103	Sd T9Rim
D1	2150	Sd FM
D#1	1469	Clap T9
E1	2112	Sd AnCR
F1	2450	Tom T9 Lo
F#1	2339	HH Closed Tek
G1	2450	Tom T9 Lo
G#1	2339	HH Closed Tek
A1	2450	Tom T9 Lo
A#1	2340	HH Open Tek
B1	2449	Tom T9 Hi
C2	2449	Tom T9 Hi
C#2	2521	Crash T9
D2	2449	Tom T9 Hi
D#2	2524	Ride T9
E2	2465	Crash3
F2	2506	Ride Cup2 L
F#2	1420	Tambourine1 Hit
G2	2465	Crash3
G#2	1461	Cowbell1
A2	2517	Splash St
A#2	1474	Cowbell T8
B2	2509	Ride Mono
C3	1363	Bongo Hi 1Finger 1-2
C#3	1376	Bongo Lo 3Finger 1-2
D3	1335	Conga Hi Tip
D#3	1341	Conga Hi Slp Open
E3	1339	Conga Hi Open 2
F3	1382	Timbale Hi1
F#3	1382	Timbale Hi1
G3	1429	Agogo Hi
G#3	1430	Agogo Lo
A3	1400	Cabasa1
A#3	1397	Maracas Slur
B3	1297	FxGun2
C4	1296	FxGun1
C#4	1312	Scratch H
D4	1314	Scratch Down
D#4	1291	Hi Q1
E4	1291	Hi Q1
F4	1292	Hi Q2
F#4	1313	Scratch L
G4	1313	Scratch L
G#4	1455	Triangle Mute
A4	1454	Triangle Open
A#4	1478	Analog Shaker
B4	1467	Sleigh Bell
C5	1468	Wind Chime
C#5	2101	Sd T9-5
D5	2101	Sd T9-5
D#5	2101	Sd T9-5
E5	2101	Sd T9-5
F5	1624	Bd Human1
F#5	2120	Sd D&B1
G5	2641	Acoustic Bass FX03
G#5	1069	DigiOsc4
A5	1068	DigiOsc3
A#5	2136	Sd Break1
B5	1628	Bd Jungle1
C6	1639	Bd Break Heavy

PRE 35 Jungle Kit

Note	Wave Number	Wave Name
C0	1629	Bd Jungle2
C#0	1919	Sd Mid Rim
D0	2118	Sd Jungle3
D#0	2118	Sd Jungle3
E0	1916	Sd Piccolo Rim1
F0	2045	Sd Roll Mono
F#0	2155	Sd Wood
G0	2126	Sd R&B2
G#0	2121	Sd D&B2
A0	1629	Bd Jungle2
A#0	2119	Sd JungleFX
B0	1619	Bd T8-1
C1	1628	Bd Jungle1
C#1	2134	Sd Hip Rim4
D1	2117	Sd Jungle2
D#1	2119	Sd JungleFX
E1	2118	Sd Jungle3
F1	2364	Tom Floor L
F#1	2241	HH Closed Rock Sw R
G1	2360	Tom Low L
G#1	2249	HH Pedal Rock Sw R
A1	2357	Tom Mid R
A#1	2264	HH Open Rock Sw R
B1	2357	Tom Mid R
C2	2353	Tom Hi R
C#2	2462	Crash2 L
D2	2353	Tom Hi R
D#2	2491	Ride2 R
E2	2516	China2
F2	2510	Ride Cup Mono
F#2	1420	Tambourine1 Hit
G2	2465	Crash3
G#2	1461	Cowbell1
A2	2461	Crash2 St
A#2	1451	Vibraslap
B2	2485	Ride1 St
C3	1363	Bongo Hi 1Finger 1-2
C#3	1376	Bongo Lo 3Finger 1-2
D3	1335	Conga Hi Tip
D#3	1341	Conga Hi Slp Open
E3	1339	Conga Hi Open 2
F3	867	Tabla Nah
F#3	866	Tabla Bya
G3	1430	Agogo Lo
G#3	1430	Agogo Lo
A3	1400	Cabasa1
A#3	1397	Maracas Slur
B3	1382	Timbale Hi1
C4	1386	Timbale Lo1
C#4	1433	Guiro Short
D4	1432	Guiro Long
D#4	1449	Clave
E4	1450	Wood Block
F4	1450	Wood Block
F#4	1362	Cuica Hi
G4	1361	Cuica Lo
G#4	1455	Triangle Mute
A4	1454	Triangle Open
A#4	1407	Shaker 2
B4	1467	Sleigh Bell
C5	1468	Wind Chime
C#5	2338	HH Reverse D&B
D5	1311	RainLoop
D#5	1312	Scratch H
E5	1313	Scratch L
F5	1627	Bd BlpHd
F#5	2152	Sd Syn
G5	1272	IndusTom
G#5	1422	Pandeiro Open
A5	1268	Ripper
A#5	1306	TelRing
B5	1318	Scratch Lo R
C6	1295	Tape Rewind

PRE 36 Electric Kit

Note	Wave Number	Wave Name
C0	1623	Bd AnCR
C#0	1626	Bd Blip
D0	2108	Sd T8-5
D#0	1470	Clap AnSm
E0	2132	Sd Hip Rim2
F0	2045	Sd Roll Mono
F#0	2104	Sd T8-1
G0	2112	Sd AnCR
G#0	2105	Sd T8-2
A0	1619	Bd T8-1
A#0	2107	Sd T8-4
B0	1626	Bd Blip
C1	1620	Bd T8-2
C#1	2109	Sd T8 Rim
D1	2106	Sd T8-3
D#1	1469	Clap T9
E1	1470	Clap AnSm
F1	2453	Tom Syn2
F#1	2328	HH Closed T8-2
G1	2453	Tom Syn2
G#1	2327	HH Open T8-1
A1	2453	Tom Syn2
A#1	2329	HH Open T8-2
B1	2453	Tom Syn2
C2	2453	Tom Syn2
C#2	2521	Crash T9
D2	2453	Tom Syn2
D#2	2524	Ride T9
E2	2465	Crash3
F2	2523	Crash Syn
F#2	2522	Crash T8
G2	2465	Crash3
G#2	2158	Sd Rim SE
A2	2461	Crash2 St
A#2	1474	Cowbell T8
B2	2523	Crash Syn
C3	2451	Tom T8
C#3	2451	Tom T8
D3	2451	Tom T8
D#3	2451	Tom T8
E3	2451	Tom T8
F3	1310	Applause
F#3	1301	Door Squeak
G3	1302	Heart Beat
G#3	1294	Bomb
A3	2345	HH Open Lo-Fi
A#3	1406	Shaker 1
B3	1275	Zap2
C4	1274	Zap1
C#4	1312	Scratch H
D4	1313	Scratch L
D#4	1291	Hi Q1
E4	1291	Hi Q1
F4	1292	Hi Q2
F#4	1313	Scratch L
G4	1179	Hit Orchestra2
G#4	2348	HH Closed FX
A4	2349	HH Open FX
A#4	1478	Analog Shaker
B4	1478	Analog Shaker
C5	1299	TurnTable
C#5	2140	Sd Break Roll
D5	1015	FM Bass5
D#5	1161	Mind Bell
E5	2137	Sd Break2
F5	1563	Bd Rock2 St
F#5	1157	Radio Noise
G5	1268	Ripper
G#5	1273	Noise Burst
A5	1326	Scratch Spin
A#5	1146	Bell Choir
B5	1149	Hi-Lo
C6	1157	Radio Noise

PRE 37 Human Kit

Note	Wave Number	Wave Name
C0	1624	Bd Human1
C#0	1323	Scratch Vo F
D0	1178	Hit Uhh
D#0	1324	Scratch Vo R
E0	2119	Sd JungleFX
F0	2036	Sd RockRoll St
F#0	2136	Sd Break1
G0	2112	Sd AnCR
G#0	2097	Sd T9-1
A0	1651	Bd Sustain
A#0	2021	Sd Hip Stick1
B0	1625	Bd Human2
C1	1625	Bd Human2
C#1	2155	Sd Wood
D1	2114	Sd Human1
D#1	2148	Sd Garg H
E1	2115	Sd Human2
F1	1624	Bd Human1
F#1	2350	HH Open Human
G1	1624	Bd Human1
G#1	2350	HH Open Human
A1	1624	Bd Human1
A#1	2350	HH Open Human
B1	1624	Bd Human1
C2	1624	Bd Human1
C#2	1273	Noise Burst
D2	1624	Bd Human1
D#2	2522	Crash T8
E2	2516	China2
F2	2510	Ride Cup Mono
F#2	1322	Scratch Sd R
G2	2517	Splash St
G#2	1180	Vox Drum
A2	2466	Crash4
A#2	1482	Electric Tambourine2
B2	1177	Stab Aah
C3	1363	Bongo Hi 1Finger 1-2
C#3	1376	Bongo Lo 3Finger 1-2
D3	1335	Conga Hi Tip
D#3	1341	Conga Hi Slip Open
E3	1339	Conga Hi Open 2
F3	1381	Timbale Hi1-3
F#3	1385	Timbale Lo1-2
G3	1430	Agogo Lo
G#3	1430	Agogo Lo
A3	1400	Cabasa1
A#3	1397	Maracas Slur
B3	1297	FxGun2
C4	1294	Bomb
C#4	1312	Scratch H
D4	1314	Scratch Down
D#4	1317	Scratch Lo F
E4	1318	Scratch Lo R
F4	1292	Hi Q2
F#4	1313	Scratch L
G4	1313	Scratch L
G#4	1455	Triangle Mute
A4	1454	Triangle Open
A#4	1407	Shaker 2
B4	1467	Sleigh Bell
C5	1299	TurnTable
C#5	1902	Sd Rock Rim1 R
D5	1303	Helicopter
D#5	1175	Stab Hard
E5	2008	Sd Gate1
F5	1560	Bd Rock1 St
F#5	1314	Scratch Down
G5	1622	Bd AnSm
G#5	1169	Sonar1
A5	861	Wataiko
A#5	861	Wataiko
B5	1143	HH Hit
C6	1176	Stab Organ2

PRE 38 Hard Kit

Note	Wave Number	Wave Name
C0	1643	Bd Distortion3
C#0	2155	Sd Wood
D0	2008	Sd Gate1
D#0	1456	HandClap St
E0	2009	Sd Gate2
F0	2045	Sd Roll Mono
F#0	2145	Sd ClapAna
G0	2129	Sd Hip3
G#0	1268	Ripper
A0	1646	Bd Distortion RM
A#0	2109	Sd T8 Rim
B0	1642	Bd Distortion2
C1	1641	Bd Distortion1
C#1	1919	Sd Mid Rim
D1	2146	Sd Dist
D#1	1273	Noise Burst
E1	2142	Sd FX2
F1	2456	Tom Dist Lo
F#1	2324	HH Closed T9
G1	2456	Tom Dist Lo
G#1	2325	HH Open T9
A1	2456	Tom Dist Lo
A#1	2325	HH Open T9
B1	2455	Tom Dist Hi
C2	2455	Tom Dist Hi
C#2	2521	Crash T9
D2	2455	Tom Dist Hi
D#2	2524	Ride T9
E2	2516	China2
F2	2510	Ride Cup Mono
F#2	1480	Tambourine AnCR
G2	2465	Crash3
G#2	1474	Cowbell T8
A2	2461	Crash2 St
A#2	1451	Vibraslap
B2	2485	Ride1 St
C3	2154	Sd Timbr
C#3	2154	Sd Timbr
D3	1335	Conga Hi Tip
D#3	1341	Conga Hi Slip Open
E3	1339	Conga Hi Open 2
F3	1647	Bd +HH
F#3	1647	Bd +HH
G3	1269	Glass
G#3	1269	Glass
A3	1400	Cabasa1
A#3	1397	Maracas Slur
B3	1297	FxGun2
C4	1296	FxGun1
C#4	1312	Scratch H
D4	1314	Scratch Down
D#4	1291	Hi Q1
E4	1291	Hi Q1
F4	1292	Hi Q2
F#4	1313	Scratch L
G4	1313	Scratch L
G#4	1455	Triangle Mute
A4	1454	Triangle Open
A#4	1478	Analog Shaker
B4	1467	Sleigh Bell
C5	1468	Wind Chime
C#5	2146	Sd Dist
D5	2150	Sd FM
D#5	2151	Sd FM Rim
E5	2153	Sd Clappy
F5	1648	Bd FxHammer
F#5	1272	IndusTorn
G5	1631	Bd D&B1
G#5	1272	IndusTorn
A5	1573	Bd Room3
A#5	1272	IndusTorn
B5	1615	Bd T9-4
C6	2156	Sd Hammer

PRE 39 Distorted Kit

Note	Wave Number	Wave Name
C0	1487	Analog Click
C#0	2046	Sd Brush Soft St
D0	2058	Sd Brush Swir St
D#0	2049	Sd Brush Med St
E0	2061	Sd Brush SwirAtt St
F0	2042	Sd LiveRoll St
F#0	1448	Castanet
G0	1768	Sd Normal 1St
G#0	1446	Stick1
A0	1565	Bd Rock2 R
A#0	1871	Sd Tight 1St
B0	1637	Bd Break1
C1	1565	Bd Rock2 R
C#1	2020	Sd Rock Stick2 R
D1	1827	Sd SonA 1L
D#1	1457	HandClap L
E1	1916	Sd Piccolo Rim1
F1	2448	Tom Ambience Lo
F#1	2252	HH Closed Rock 2R
G1	2448	Tom Ambience Lo
G#1	2256	HH Pedal Rock R
A1	2448	Tom Ambience Lo
A#1	2266	HH Open Rock R
B1	2447	Tom Ambience Hi
C2	2447	Tom Ambience Hi
C#2	2462	Crash2 L
D2	2447	Tom Ambience Hi
D#2	2491	Ride2 R
E2	2513	China L
F2	2507	Ride Cup2 R
F#2	1419	Tambourine1 Sw
G2	2519	Splash R
G#2	1464	Mambo Bl2
A2	2462	Crash2 L
A#2	1451	Vibraslap
B2	2485	Ride1 St
C3	1363	Bongo Hi 1Finger 1-2
C#3	1376	Bongo Lo 3Finger 1-2
D3	1335	Conga Hi Tip
D#3	1341	Conga Hi Slip Open
E3	1339	Conga Hi Open 2
F3	1381	Timbale Hi1-3
F#3	1385	Timbale Lo1-2
G3	1429	Agogo Hi
G#3	1430	Agogo Lo
A3	1399	Cabasa1-2
A#3	1397	Maracas Slur
B3	1452	Whistle
C4	1452	Whistle
C#4	1433	Guiro Short
D4	1432	Guiro Long
D#4	1449	Clave
E4	1450	Wood Block
F4	1450	Wood Block
F#4	1332	Scratch Combi2
G4	1316	Scratch Hi R
G#4	1455	Triangle Mute
A4	1454	Triangle Open
A#4	1406	Shaker 1
B4	1467	Sleigh Bell
C5	1468	Wind Chime
C#5	1915	Sd Piccolo
D5	2013	Sd Heavy
D#5	2145	Sd ClapAna
E5	1916	Sd Piccolo Rim1
F5	1572	Bd Room2
F#5	1918	Sd Mid
G5	1573	Bd Room3
G#5	1919	Sd Mid Rim
A5	1610	Bd Gate
A#5	2008	Sd Gate1
B5	1611	Bd FX Gate
C6	1631	Bd D&B1

PRE 40 Ambient Kit

Note	Wave Number	Wave Name
C0	1626	Bd Blip
C#0	1292	Hi Q2
D0	1917	Sd Piccolo Rim2
D#0	1291	Hi Q1
E0	2112	Sd AnCR
F0	2452	Tom Syn1
F#0	2346	HH Closed Syn
G0	2452	Tom Syn1
G#0	2348	HH Closed FX
A0	2453	Tom Syn2
A#0	2347	HH Open Syn
B0	1623	Bd AnCR
C1	1612	Bd T9-1
C#1	2023	Sd Hip Stick3
D1	2116	Sd Jungle1
D#1	1469	Clap T9
E1	2116	Sd Jungle1
F1	2451	Tom T8
F#1	2328	HH Closed T8-2
G1	2451	Tom T8
G#1	2327	HH Open T8-1
A1	2451	Tom T8
A#1	2329	HH Open T8-2
B1	2451	Tom T8
C2	2451	Tom T8
C#2	2523	Crash Syn
D2	2451	Tom T8
D#2	2524	Ride T9
E2	2465	Crash3
F2	2510	Ride Cup Mono
F#2	1420	Tambourine1 Hit
G2	2465	Crash3
G#2	1474	Cowbell T8
A2	2461	Crash2 St
A#2	1451	Vibraslap
B2	2485	Ride1 St
C3	1363	Bongo Hi 1Finger 1-2
C#3	1376	Bongo Lo 3Finger 1-2
D3	1335	Conga Hi Tip
D#3	1341	Conga Hi Slip Open
E3	1339	Conga Hi Open 2
F3	1381	Timbale Hi1-3
F#3	1385	Timbale Lo1-2
G3	1269	Glass
G#3	1269	Glass
A3	1400	Cabasa1
A#3	1483	MaracasT8
B3	1307	Bird
C4	1183	Engine Room St
C#4	1289	Electric Perc14
D4	1309	Gunshot
D#4	1485	Clave T8
E4	1450	Wood Block
F4	1450	Wood Block
F#4	1480	Tambourine AnCR
G4	1476	Cowbell AnCR
G#4	1455	Triangle Mute
A4	1454	Triangle Open
A#4	1478	Analog Shaker
B4	1467	Sleigh Bell
C5	1468	Wind Chime
C#5	2108	Sd T8-5
D5	1169	Sonar1
D#5	2108	Sd T8-5
E5	1169	Sonar1
F5	1153	Bubble
F#5	2108	Sd T8-5
G5	1153	Bubble
G#5	2108	Sd T8-5
A5	1141	Eery
A#5	2108	Sd T8-5
B5	1136	FX Chime
C6	1136	FX Chime

PRE 41 Garage Kit

Note	Wave Number	Wave Name
C0	1653	Bd Hard Long
C#0	1612	Bd T9-1
D0	1658	Bd Slimy
D#0	1655	Bd AnaHard
E0	1644	Bd Distortion4
F0	1665	Bd ElecComp3
F#0	1635	Bd Hip Deep
G0	1648	Bd FxHammer
G#0	1614	Bd T9-3
A0	1621	Bd T8-3
A#0	1651	Bd Sustain
B0	1634	Bd R&B2
C1	1616	Bd T9 Hd1
C#1	1658	Bd Slimy
D1	2104	Sd T8-1
D#1	2109	Sd T8 Rim
E1	2153	Sd Clappy
F1	1841	Sd Blues 3St
F#1	2212	HH Open 2St
G1	2328	HH Closed T8-2
G#1	2212	HH Open 2St
A1	2329	HH Open T8-2
A#1	2212	HH Open 2St
B1	2329	HH Open T8-2
C2	1470	Clap AnSm
C#2	2461	Crash2 St
D2	2521	Crash T9
D#2	2485	Ride1 St
E2	2524	Ride T9
F2	1487	Analog Click
F#2	1485	Clave T8
G2	1470	Clap AnSm
G#2	1469	Clap T9
A2	1478	Analog Shaker
A#2	1473	Conga T8
B2	1473	Conga T8
C3	2112	Sd AnCR
C#3	2036	Sd RockRoll St
D3	1429	Agogo Hi
D#3	2515	China RL
E3	1292	Hi Q2
F3	1291	Hi Q1
F#3	1275	Zap2
G3	1274	Zap1
G#3	1275	Zap2
A3	1301	Door Squeak
A#3	1333	Scratch Combi3
B3	2604	AcousticGtr FX27 St
C4	335	Play FX Mix
C#4	1315	Scratch Hi F
D4	44	Brite Piano
D#4	44	Brite Piano
E4	44	Brite Piano
F4	1164	Resonance X-Fade
F#4	1169	Sonar1
G4	1180	Vox Drum
G#4	1180	Vox Drum
A4	1180	Vox Drum
A#4	2347	HH Open Syn
B4	2346	HH Closed Syn
C5	1044	Tri Wave
C#5	1044	Tri Wave
D5	1044	Tri Wave
D#5	1044	Tri Wave
E5	1044	Tri Wave
F5	1044	Tri Wave
F#5	1044	Tri Wave
G5	1044	Tri Wave
G#5	1044	Tri Wave
A5	1044	Tri Wave
A#5	1044	Tri Wave
B5	1044	Tri Wave
C6	1044	Tri Wave

PRE 42 Synth Pop Kit

Note	Wave Number	Wave Name
C0	1679	Bd HipHop8
C#0	1612	Bd T9-1
D0	1626	Bd Blip
D#0	1640	Bd Break Hard
E0	1666	Bd ElecFX1
F0	1668	Bd ElecGate
F#0	1667	Bd ElecFX2
G0	1642	Bd Distortion2
G#0	1657	Bd ThickSkin
A0	1664	Bd ElecComp2
A#0	1660	Bd Elec2
B0	1669	Bd ElecClick
C1	1669	Bd ElecClick
C#1	2103	Sd T9Rim
D1	2096	Sd Elec12
D#1	1469	Clap T9
E1	2092	Sd Elec8
F1	2450	Tom T9 Lo
F#1	2324	HH Closed T9
G1	2450	Tom T9 Lo
G#1	2325	HH Open T9
A1	2450	Tom T9 Lo
A#1	2325	HH Open T9
B1	2449	Tom T9 Hi
C2	2449	Tom T9 Hi
C#2	2521	Crash T9
D2	2449	Tom T9 Hi
D#2	2524	Ride T9
E2	2521	Crash T9
F2	2524	Ride T9
F#2	1482	Electric Tambourine2
G2	2521	Crash T9
G#2	1477	Electric Cowbell
A2	2521	Crash T9
A#2	1481	Electric Tambourine1
B2	2524	Ride T9
C3	1280	Electric Perc5
C#3	1279	Electric Perc4
D3	1287	Electric Perc12
D#3	1281	Electric Perc16
E3	1276	Electric Perc1
F3	1270	Bell FX1
F#3	1271	Bell FX2
G3	1329	Scratch Attack
G#3	1330	Scratch R&B
A3	1399	Cabasa1-2
A#3	1397	Maracas Slur
B3	1289	Electric Perc14
C4	1290	Electric Perc15
C#4	1410	Shaker Hjp2
D4	1278	Electric Perc3
D#4	1282	Electric Perc7
E4	1283	Electric Perc8
F4	1284	Electric Perc9
F#4	1285	Electric Perc10
G4	1288	Electric Perc13
G#4	1455	Triangle Mute
A4	1454	Triangle Open
A#4	1484	Electric Maracas
B4	1486	Electric Triangle
C5	1286	Electric Perc11
C#5	2085	Sd Elec1
D5	2093	Sd Elec9
D#5	2094	Sd Elec10
E5	2095	Sd Elec11
F5	2086	Sd Elec2
F#5	2087	Sd Elec3
G5	2088	Sd Elec4
G#5	2089	Sd Elec5
A5	2090	Sd Elec6
A#5	2091	Sd Elec7
B5	1471	Electric Clap1
C6	1472	Electric Clap2

PRE 43 Orchestra Kit

Note	Wave Number	Wave Name
C0	1487	Analog Click
C#0	2050	Sd Brush Med L
D0	2060	Sd Brush Swir R
D#0	2050	Sd Brush Med L
E0	2063	Sd Brush SwirAtt R
F0	2082	Sd Orch Roll St
F#0	1448	Castanet
G0	2065	Sd Orch1 S St
G#0	1446	Stick1
A0	1607	Bd Gran Casa Mute St
A#0	2070	Sd Orch1 H L
B0	1607	Bd Gran Casa Mute St
C1	1604	Bd Gran Casa Open St
C#1	2033	Sd Closed Rim R
D1	2066	Sd Orch1 H St
D#1	1456	HandClap St
E1	2075	Sd Orch2 H St
F1	137	Timpani Sw St
F#1	2174	HH Closed 1-4St
G1	137	Timpani Sw St
G#1	2199	HH Pedal 1-3 R
A1	137	Timpani Sw St
A#1	2210	HH Open 1-2St
B1	137	Timpani Sw St
C2	137	Timpani Sw St
C#2	2479	Hand Cymbal Open St
D2	137	Timpani Sw St
D#2	2485	Ride1 St
E2	2512	China St
F2	2493	Ride Cup1 St
F#2	1420	Tambourine1 Hit
G2	2482	Hand Cymbal Mute St
G#2	1462	Cowbell2
A2	2457	Crash1 St
A#2	1451	Vibraslap
B2	2489	Ride2 St
C3	1363	Bongo Hi 1Finger 1-2
C#3	1376	Bongo Lo 3Finger 1-2
D3	1335	Conga Hi Tip
D#3	1339	Conga Hi Open 2
E3	1357	Tumba Open
F3	1381	Timbale Hi1-3
F#3	1385	Timbale Lo1-2
G3	1429	Agogo Hi
G#3	1430	Agogo Lo
A3	1399	Cabasa1-2
A#3	1397	Maracas Slur
B3	1452	Whistle
C4	1452	Whistle
C#4	1433	Guiro Short
D4	1432	Guiro Long
D#4	1449	Clave
E4	1450	Wood Block
F4	1450	Wood Block
F#4	1362	Cuica Hi
G4	1361	Cuica Lo
G#4	1455	Triangle Mute
A4	1454	Triangle Open
A#4	1406	Shaker 1
B4	1467	Sleigh Bell
C5	1468	Wind Chime
C#5	1450	Wood Block
D5	1450	Wood Block
D#5	1450	Wood Block
E5	1450	Wood Block
F5	1450	Wood Block
F#5	1450	Wood Block
G5	1450	Wood Block
G#5	1450	Wood Block
A5	1450	Wood Block
A#5	1450	Wood Block
B5	1450	Wood Block
C6	1450	Wood Block

PRE 44 Drum Machines Kit

Note	Wave Number	Wave Name
C0	1653	Bd Hard Long
C#0	1652	Bd TekPower
D0	1645	Bd Distortion5
D#0	1643	Bd Distortion3
E0	1641	Bd Distortion1
F0	1631	Bd D&B1
F#0	1626	Bd Blip
G0	1622	Bd AnSm
G#0	1620	Bd T8-2
A0	1621	Bd T8-3
A#0	1618	Bd T9 Hd3
B0	1613	Bd T9-2
C1	1614	Bd T9-3
C#1	2103	Sd T9Rim
D1	2097	Sd T9-1
D#1	1469	Clap T9
E1	2100	Sd T9-4
F1	2450	Tom T9 Lo
F#1	2324	HH Closed T9
G1	2450	Tom T9 Lo
G#1	2325	HH Open T9
A1	2450	Tom T9 Lo
A#1	2325	HH Open T9
B1	2450	Tom T9 Lo
C2	2450	Tom T9 Lo
C#2	2521	Crash T9
D2	1473	Conga T8
D#2	2524	Ride T9
E2	1473	Conga T8
F2	1487	Analog Click
F#2	1485	Clave T8
G2	1483	MaracasT8
G#2	1480	Tambourine AnCR
A2	1478	Analog Shaker
A#2	1474	Cowbell T8
B2	1476	Cowbell AnCR
C3	2104	Sd T8-1
C#3	2105	Sd T8-2
D3	2106	Sd T8-3
D#3	2112	Sd AnCR
E3	2116	Sd Jungle1
F3	2120	Sd D&B1
F#3	2127	Sd Hip1
G3	2124	Sd R&B1
G#3	2126	Sd R&B2
A3	2127	Sd Hip1
A#3	2155	Sd Wood
B3	2154	Sd Timbr
C4	2326	HH Closed T8-1
C#4	2327	HH Open T8-1
D4	2328	HH Closed T8-2
D#4	2329	HH Open T8-2
E4	2197	HH Pedal 3 St
F4	2212	HH Open 2St
F#4	2212	HH Open 2St
G4	2344	HH Closed Lo-Fi
G#4	2345	HH Open Lo-Fi
A4	2346	HH Closed Syn
A#4	2347	HH Open Syn
B4	1478	Analog Shaker
C5	1479	Tambourine RX5
C#5	1479	Tambourine RX5
D5	1477	Electric Cowbell
D#5	1473	Conga T8
E5	1486	Electric Triangle
F5	1485	Clave T8
F#5	1478	Analog Shaker
G5	1471	Electric Clap1
G#5	1472	Electric Clap2
A5	1480	Tambourine AnCR
A#5	1474	Cowbell T8
B5	1487	Analog Click
C6	1475	Cowbell RX11

PRE 45 Rock Multiple Kits

Note	Wave Number	Wave Name
C0	1527	Bd Normal St1-2
C#0	2015	Sd Rock Stick1 St
D0	1903	Sd Rock Open2 St
D#0	2036	Sd RockRoll St
E0	1894	Sd Rock Open1 St
F0	2359	Tom Low St
F#0	2222	HH Closed Foot St
G0	2359	Tom Low St
G#0	2197	HH Pedal 3 St
A0	2355	Tom Mid St
A#0	2212	HH Open 2St
B0	2351	Tom Hi St
C1	1563	Bd Rock2 St
C#1	2015	Sd Rock Stick1 St
D1	1903	Sd Rock Open2 St
D#1	1456	HandClap St
E1	1906	Sd Rock Mute2 St
F1	2375	Tom Rock Low St
F#1	2234	HH Closed Rock Sw St
G1	2375	Tom Rock Low St
G#1	2246	HH Pedal Rock Sw St
A1	2371	Tom Rock Mid St
A#1	2258	HH Open Rock Sw St
B1	2371	Tom Rock Mid St
C2	2367	Tom Rock Hi St
C#2	2461	Crash2 St
D2	2367	Tom Rock Hi St
D#2	2485	Ride1 St
E2	2512	China St
F2	2493	Ride Cup1 St
F#2	1419	Tambourine1 Sw
G2	2517	Splash St
G#2	1461	Cowbell1
A2	2461	Crash2 St
A#2	1406	Shaker 1
B2	2485	Ride1 St
C3	1560	Bd Rock1 St
C#3	2018	Sd Rock Stick2 St
D3	1894	Sd Rock Open1 St
D#3	1469	Clap T9
E3	1897	Sd Rock Mute1 St
F3	2375	Tom Rock Low St
F#3	2234	HH Closed Rock Sw St
G3	2375	Tom Rock Low St
G#3	2254	HH Pedal Rock St
A3	2371	Tom Rock Mid St
A#3	2262	HH Half Open Rock St
B3	2371	Tom Rock Mid St
C4	2367	Tom Rock Hi St
C#4	2461	Crash2 St
D4	2367	Tom Rock Hi St
D#4	2490	Ride2 L
E4	2512	China St
F4	2493	Ride Cup1 St
F#4	1420	Tambourine1 Hit
G4	2517	Splash St
G#4	1464	Mambo B12
A4	2461	Crash2 St
A#4	1413	Shekere Down
B4	2491	Ride2 R
C5	1536	Bd Funk St1-2
C#5	2015	Sd Rock Stick1 St
D5	1900	Sd Rock Rim1 St
D#5	1912	Sd Rock Flam St
E5	1909	Sd Rock Rim2 St
F5	2363	Tom Floor St
F#5	2178	HH Closed 4St
G5	2359	Tom Low St
G#5	2197	HH Pedal 3 St
A5	2355	Tom Mid St
A#5	2230	HH Open2 St
B5	2355	Tom Mid St
C6	2351	Tom Hi St

PRE 46 HipHop Multiple Kits

Note	Wave Number	Wave Name
C0	1621	Bd T8-3
C#0	2109	Sd T8 Rim
D0	2167	Sd HipHop11
D#0	1469	Clap T9
E0	2165	Sd HipHop9
F0	1621	Bd T8-3
F#0	2339	HH Closed Tek
G0	1621	Bd T8-3
G#0	2340	HH Open Tek
A0	1621	Bd T8-3
A#0	2340	HH Open Tek
B0	1621	Bd T8-3
C1	1635	Bd Hip Deep
C#1	2024	Sd Hip Stick4
D1	2131	Sd Hip Rim1
D#1	1488	HipHop clap1
E1	2128	Sd Hip2
F1	2451	Tom T8
F#1	2328	HH Closed T8-2
G1	2451	Tom T8
G#1	2332	HH Open AnCR
A1	2451	Tom T8
A#1	2327	HH Open T8-1
B1	2451	Tom T8
C2	2451	Tom T8
C#2	2521	Crash T9
D2	2451	Tom T8
D#2	2523	Crash Syn
E2	2523	Crash Syn
F2	2522	Crash T8
F#2	1479	Tambourine RX5
G2	2519	Splash R
G#2	1474	Cowbell T8
A2	2521	Crash T9
A#2	1476	Cowbell AnCR
B2	2524	Ride T9
C3	1635	Bd Hip Deep
C#3	2025	Sd Hip Stick5
D3	2132	Sd Hip Rim2
D#3	1489	HipHop clap2
E3	2127	Sd Hip1
F3	2450	Tom T9 Lo
F#3	2330	HH Closed RX5
G3	2450	Tom T9 Lo
G#3	2331	HH Closed AnCR
A3	2450	Tom T9 Lo
A#3	2329	HH Open T8-2
B3	2450	Tom T9 Lo
C4	2449	Tom T9 Hi
C#4	2463	Crash2 R
D4	2449	Tom T9 Hi
D#4	2522	Crash T8
E4	2523	Crash Syn
F4	2522	Crash T8
F#4	1420	Tambourine1 Hit
G4	2514	China R
G#4	1475	Cowbell RX11
A4	2462	Crash2 L
A#4	1461	Cowbell1
B4	2491	Ride2 R
C5	1635	Bd Hip Deep
C#5	2171	Sd HipHop Rim4
D5	2160	Sd HipHop2
D#5	1489	HipHop clap2
E5	2135	Sd Hip Rim5
F5	2456	Tom Dist Lo
F#5	2341	HH Closed Hip
G5	2456	Tom Dist Lo
G#5	2342	HH Pedal Hip
A5	2455	Tom Dist Hi
A#5	2343	HH Open Hip
B5	2455	Tom Dist Hi
C6	2455	Tom Dist Hi

PRE 47 Percussion Kit

Note	Wave Number	Wave Name
C0	861	Wataiko
C#0	886	Udo High
D0	864	Djembe Open
D#0	1353	Quinto1 Open
E0	887	Udo Low
F0	885	Udo Finger
F#0	886	Udo High
G0	866	Tabla Bya
G#0	1426	Tmbourim Open
A0	868	Tabla Mute
A#0	867	Tabla Nah
B0	868	Tabla Mute
C1	137	Timpani Sw St
C#1	1178	Hit Uhh
D1	1363	Bongo Hi 1Finger 1-2
D#1	1469	Clap T9
E1	1455	Triangle Mute
F1	1454	Triangle Open
F#1	1448	Castanet
G1	1448	Castanet
G#1	1448	Castanet
A1	1432	Guiro Long
A#1	1434	Guiro Swp
B1	1433	Guiro Short
C2	1451	Vibraslap
C#2	1449	Clave
D2	1485	Clave T8
D#2	1361	Cuica Lo
E2	1362	Cuica Hi
F2	1385	Timbale Lo1-2
F#2	1450	Wood Block
G2	1387	Timbale Lo2
G#2	1450	Wood Block
A2	1381	Timbale Hi1-3
A#2	1466	ChaCha
B2	1383	Timbale Hi2
C3	1390	Timbale Paila L
C#3	1390	Timbale Paila L
D3	1389	Timbale Paila H
D#3	1463	Mambo B1
E3	1376	Bongo Lo 3Finger 1-2
F3	1376	Bongo Lo 3Finger 1-2
F#3	1459	Handbell L
G3	1363	Bongo Hi 1Finger 1-2
G#3	1460	Handbell H
A3	1363	Bongo Hi 1Finger 1-2
A#3	1430	Agogo Lo
B3	1429	Agogo Hi
C4	1336	Conga Hi Heel
C#4	1335	Conga Hi Tip
D4	1358	Tumba Slap
D#4	1397	Maracas Slur
E4	1357	Tumba Open
F4	1336	Conga Hi Heel
F#4	1335	Conga Hi Tip
G4	1341	Conga Hi Slp Open
G#4	1406	Shaker 1
A4	1339	Conga Hi Open 2
A#4	1400	Cabasa 1
B4	1399	Cabasa1-2
C5	1336	Conga Hi Heel
C#5	1335	Conga Hi Tip
D5	1354	Quinto1 Slap
D#5	1406	Shaker 1
E5	1355	Quinto2 Open
F5	1402	Caxixi1-2
F#5	1421	Tambourine1 Shake
G5	1420	Tambourine1 Hit
G#5	1419	Tambourine1 Sw
A5	1420	Tambourine1 Hit
A#5	1467	Sleigh Bell
B5	1452	Whistle
C6	1452	Whistle

PRE 48 Latin Percussion Kit

Note	Wave Number	Wave Name
C0	1554	Bd L Son St
C#0	2018	Sd Rock Stick2 St
D0	1785	Sd Funk St1/3
D#0	2461	Crash2 St
E0	2517	Splash St
F0	2359	Tom Low St
F#0	2174	HH Closed 1-4St
G0	2359	Tom Low St
G#0	2197	HH Pedal 3 St
A0	2355	Tom Mid St
A#0	2212	HH Open 2St
B0	2351	Tom Hi St
C1	1335	Conga Hi Tip
C#1	1336	Conga Hi Heel
D1	1358	Tumba Slap
D#1	1449	Clave
E1	1357	Tumba Open
F1	1335	Conga Hi Tip
F#1	1336	Conga Hi Heel
G1	1341	Conga Hi Slp Open
G#1	1459	Handbell L
A1	1339	Conga Hi Open 2
A#1	1460	Handbell H
B1	1463	Mambo B11
C2	1335	Conga Hi Tip
C#2	1336	Conga Hi Heel
D2	1354	Quinto1 Slap
D#2	1466	ChaCha
E2	1353	Quinto1 Open
F2	1376	Bongo Lo 3Finger 1-2
F#2	1363	Bongo Hi 1Finger 1-2
G2	1366	Bongo Hi 3Finger 1-2
G#2	1386	Timbale Lo1
A2	1390	Timbale Paila L
A#2	1382	Timbale Hi1
B2	1389	Timbale Paila H
C3	1450	Wood Block
C#3	1450	Wood Block
D3	1413	Shekere Down
D#3	1414	Shekere Up
E3	1415	Shekere Sap
F3	1397	Maracas Slur
F#3	1398	Maracas Staccato
G3	1432	Guiro Long
G#3	1434	Guiro Swp
A3	1433	Guiro Short
A#3	1440	Surdo Mute
B3	1439	Surdo Open
C4	1424	Pandeiro Tip
C#4	1425	Pandeiro Heel
D4	1423	Pandeiro Thump
D#4	1422	Pandeiro Open
E4	1427	Tmbourim Finger
F4	1426	Tmbourim Open
F#4	1428	Tmbourim Mute
G4	1431	Agogo Lo Tap
G#4	1430	Agogo Lo
A4	1429	Agogo Hi
A#4	1454	Triangle Open
B4	1455	Triangle Mute
C5	1407	Shaker 2
C#5	1406	Shaker 1
D5	1408	Shaker 3
D#5	1400	Cabasa 1
E5	1401	Cabasa2
F5	1403	Caxixi1
F#5	1404	Caxixi2
G5	1361	Cuica Lo
G#5	1362	Cuica Hi
A5	1452	Whistle
A#5	1452	Whistle
B5	1451	Vibraslap
C6	1468	Wind Chime

PRE 49 Guitar/Bass FX Kit

Note	Wave Number	Wave Name
C0	2644	Acoustic Bass FX06
C#0	2644	Acoustic Bass FX06
D0	335	Play FX Mix
D#0	334	Power Chord Mono
E0	334	Power Chord Mono
F0	2639	Acoustic Bass FX01
F#0	2529	AcousticGtr FX02 St
G0	2652	Electric Bass FX 05
G#0	2663	Electric Bass FX 16
A0	2648	Electric Bass FX 01
A#0	2621	ElectricGtr FX06
B0	2664	Electric Bass FX 17
C1	2651	Electric Bass FX 04
C#1	2657	Electric Bass FX 10
D1	335	Play FX Mix
D#1	2658	Electric Bass FX 11
E1	335	Play FX Mix
F1	2665	Electric Bass FX 18
F#1	2663	Electric Bass FX 16
G1	2665	Electric Bass FX 18
G#1	2664	Electric Bass FX 17
A1	2665	Electric Bass FX 18
A#1	2628	ElectricGtr FX13
B1	2665	Electric Bass FX 18
C2	2665	Electric Bass FX 18
C#2	2610	AcousticGtr FX29 St
D2	2665	Electric Bass FX 18
D#2	2658	Electric Bass FX 11
E2	2610	AcousticGtr FX29 St
F2	2658	Electric Bass FX 11
F#2	2657	Electric Bass FX 10
G2	2610	AcousticGtr FX29 St
G#2	335	Play FX Mix
A2	2610	AcousticGtr FX29 St
A#2	2660	Electric Bass FX 13
B2	2658	Electric Bass FX 11
C3	2657	Electric Bass FX 10
C#3	2657	Electric Bass FX 10
D3	2649	Electric Bass FX 02
D#3	2655	Electric Bass FX 08
E3	2665	Electric Bass FX 18
F3	2647	Acoustic Bass FX09
F#3	2647	Acoustic Bass FX09
G3	2645	Acoustic Bass FX07
G#3	2645	Acoustic Bass FX07
A3	2644	Acoustic Bass FX06
A#3	2647	Acoustic Bass FX09
B3	335	Play FX Mix
C4	335	Play FX Mix
C#4	2669	Electric Bass FX 22
D4	2541	AcousticGtr FX06 St
D#4	2663	Electric Bass FX 16
E4	2663	Electric Bass FX 16
F4	2650	Electric Bass FX 03
F#4	335	Play FX Mix
G4	335	Play FX Mix
G#4	2658	Electric Bass FX 11
A4	2664	Electric Bass FX 17
A#4	2529	AcousticGtr FX02 St
B4	2661	Electric Bass FX 14
C5	2636	ElectricGtr FX21
C#5	2635	ElectricGtr FX20
D5	2634	ElectricGtr FX19
D#5	335	Play FX Mix
E5	335	Play FX Mix
F5	335	Play FX Mix
F#5	335	Play FX Mix
G5	385	Electric Bass FX
G#5	2669	Electric Bass FX 22
A5	2652	Electric Bass FX 05
A#5	2662	Electric Bass FX 15
B5	385	Electric Bass FX
C6	2666	Electric Bass FX 19

PRE 50 Wacko Kit

Note	Wave Number	Wave Name
C0	2648	Electric Bass FX 01
C#0	1275	Zap2
D0	2336	HH Pedal D&B
D#0	1457	HandClap L
E0	1323	Scratch Vo F
F0	1272	IndusTom
F#0	2155	Sd Wood
G0	1272	IndusTom
G#0	2145	Sd ClapAna
A0	1272	IndusTom
A#0	2151	Sd FM Rim
B0	1611	Bd FX Gate
C1	1648	Bd FxHammer
C#1	1341	Conga Hi Slp Open
D1	2150	Sd FM
D#1	1457	HandClap L
E1	2154	Sd Timbr
F1	2453	Tom Syn2
F#1	2346	HH Closed Syn
G1	2453	Tom Syn2
G#1	2347	HH Open Syn
A1	2453	Tom Syn2
A#1	2347	HH Open Syn
B1	2453	Tom Syn2
C2	2453	Tom Syn2
C#2	2271	HH Open Mono
D2	1169	Sonar1
D#2	2327	HH Open T8-1
E2	2271	HH Open Mono
F2	2506	Ride Cup2 L
F#2	1467	Sleigh Bell
G2	2329	HH Open T8-2
G#2	1164	Resonance X-Fade
A2	2462	Crash2 L
A#2	1311	RainLoop
B2	2507	Ride Cup2 R
C3	1151	AirHose L
C#3	1151	AirHose L
D3	886	Udo High
D#3	991	Mg Bass2
E3	993	Mg Bass3
F3	2644	Acoustic Bass FX06
F#3	2644	Acoustic Bass FX06
G3	1430	Agogo Lo
G#3	1430	Agogo Lo
A3	2350	HH Open Human
A#3	1293	Vox Hit Rev
B3	1291	Hi Q1
C4	1291	Hi Q1
C#4	1166	LFO Seq
D4	1166	LFO Seq
D#4	1137	BellAir
E4	1143	HH Hit
F4	1143	HH Hit
F#4	1158	Ooh Feedback
G4	1158	Ooh Feedback
G#4	1161	Mind Bell
A4	1269	Glass
A#4	1154	Swarm
B4	1297	FxGun2
C5	1155	Lektronica
C#5	335	Play FX Mix
D5	1309	Gunshot
D#5	1300	Police
E5	1268	Ripper
F5	335	Play FX Mix
F#5	1295	Tape Rewind
G5	1296	FxGun1
G#5	1294	Bomb
A5	1275	Zap2
A#5	1273	Noise Burst
B5	1174	Stab Giant
C6	1173	Stab Orchestra

PRE 51 Wood Bits Kit

Note	Wave Number	Wave Name
C0	1485	Clave T8
C#0	2027	Sd Hip Stick6 L
D0	1432	Guiro Long
D#0	2028	Sd Hip Stick6 R
E0	1432	Guiro Long
F0	2562	AcousticGtr FX13 St
F#0	1448	Castanet
G0	2658	Electric Bass FX 11
G#0	1446	Stick1
A0	2655	Electric Bass FX 08
A#0	2654	Electric Bass FX 07
B0	2449	Tom T9 Hi
C1	2664	Electric Bass FX 17
C#1	2035	Sd Closed Rim3
D1	1447	Stick2
D#1	1432	Guiro Long
E1	1447	Stick2
F1	1439	Surdo Open
F#1	2111	Sd AnSm Rim
G1	1439	Surdo Open
G#1	1470	Clap AnSm
A1	1439	Surdo Open
A#1	1451	Vibraslap
B1	1439	Surdo Open
C2	1439	Surdo Open
C#2	1304	Seashore
D2	1439	Surdo Open
D#2	2018	Sd Rock Stick2 St
E2	1310	Applause
F2	2016	Sd Rock Stick1 L
F#2	1421	Tambourine1 Shake
G2	1304	Seashore
G#2	1450	Wood Block
A2	1310	Applause
A#2	1303	Helicopter
B2	2020	Sd Rock Stick2 R
C3	1341	Conga Hi Slp Open
C#3	1341	Conga Hi Slp Open
D3	1448	Castanet
D#3	1448	Castanet
E3	1450	Wood Block
F3	1390	Timbale Paila L
F#3	1390	Timbale Paila L
G3	1446	Stick1
G#3	1447	Stick2
A3	1402	Caxixi1-2
A#3	1404	Caxixi2
B3	1301	Door Squeak
C4	1301	Door Squeak
C#4	1433	Guiro Short
D4	1432	Guiro Long
D#4	1449	Clave
E4	1450	Wood Block
F4	1450	Wood Block
F#4	1301	Door Squeak
G4	1301	Door Squeak
G#4	1450	Wood Block
A4	1449	Clave
A#4	1301	Door Squeak
B4	1457	HandClap L
C5	1466	ChaCha
C#5	1903	Sd Rock Open2 St
D5	1630	Bd Jungle3
D#5	1354	Quinto1 Slap
E5	1572	Bd Room2
F5	1551	Bd H Son St
F#5	2013	Sd Heavy
G5	1439	Surdo Open
G#5	2015	Sd Rock Stick1 St
A5	1658	Bd Slimy
A#5	2008	Sd Gate1
B5	1557	Bd Funk Son St
C6	1610	Bd Gate

PRE 52 Metal Bits Kit

Note	Wave Number	Wave Name
C0	1474	Cowbell T8
C#0	2188	HH Closed 4R
D0	2507	Ride Cup2 R
D#0	2347	HH Open Syn
E0	2506	Ride Cup2 L
F0	2493	Ride Cup1 St
F#0	1026	FM Metal2
G0	2485	Ride1 St
G#0	1282	Electric Perc7
A0	1462	Cowbell2
A#0	2175	HH Closed 1St
B0	1466	ChaCha
C1	1462	Cowbell2
C#1	2346	HH Closed Syn
D1	2340	HH Open Tek
D#1	2328	HH Closed T8-2
E1	2330	HH Closed RX5
F1	1462	Cowbell2
F#1	2327	HH Open T8-1
G1	1462	Cowbell2
G#1	2346	HH Closed Syn
A1	1462	Cowbell2
A#1	2347	HH Open Syn
B1	1462	Cowbell2
C2	1462	Cowbell2
C#2	2349	HH Open FX
D2	1462	Cowbell2
D#2	2493	Ride Cup1 St
E2	2332	HH Open AnCR
F2	2493	Ride Cup1 St
F#2	1419	Tambourine1 Sw
G2	2349	HH Open FX
G#2	1464	Mambo BI2
A2	2349	HH Open FX
A#2	1467	Sleigh Bell
B2	2509	Ride Mono
C3	44	Brite Piano
C#3	44	Brite Piano
D3	124	Tubular Bell
D#3	125	Bell
E3	128	Brass Bell
F3	1389	Timbale Paila H
F#3	1390	Timbale Paila L
G3	125	Bell
G#3	125	Bell
A3	2175	HH Closed 1St
A#3	2332	HH Open AnCR
B3	1137	BellAir
C4	1136	FX Chime
C#4	2265	HH Open Rock L
D4	1155	Lektronica
D#4	1430	Agogo Lo
E4	1461	Cowbell1
F4	1462	Cowbell2
F#4	1149	Hi-Lo
G4	1149	Hi-Lo
G#4	1455	Triangle Mute
A4	1454	Triangle Open
A#4	1136	FX Chime
B4	1467	Sleigh Bell
C5	1468	Wind Chime
C#5	129	Small Bell
D5	129	Small Bell
D#5	128	Brass Bell
E5	132	Hibashi
F5	44	Brite Piano
F#5	2010	Sd LdwHMono
G5	44	Brite Piano
G#5	2011	Sd BreakRim
A5	857	Gamelan2
A#5	885	Udo Finger
B5	130	Finger Cymbal
C6	125	Bell

PRE 53 Hands Kit

Note	Wave Number	Wave Name
C0	868	Tabla Mute
C#0	2046	Sd Brush Soft St
D0	2058	Sd Brush Swir St
D#0	2049	Sd Brush Med St
E0	2061	Sd Brush SwirAtt St
F0	2610	AcousticGtr FX29 St
F#0	1447	Stick2
G0	1423	Pandeiro Thump
G#0	868	Tabla Mute
A0	2663	Electric Bass FX 16
A#0	2574	AcousticGtr FX17 St
B0	869	Tabla Combi
C1	861	Wataiko
C#1	1354	Quinto1 Slap
D1	2049	Sd Brush Med St
D#1	1456	HandClap St
E1	1797	Sd Funk Ay St
F1	887	Udo Low
F#1	868	Tabla Mute
G1	887	Udo Low
G#1	866	Tabla Bya
A1	886	Udo High
A#1	867	Tabla Nah
B1	886	Udo High
C2	885	Udo Finger
C#2	2491	Ride2 R
D2	885	Udo Finger
D#2	2493	Ride Cup1 St
E2	2511	Ride Cup Mono2
F2	2493	Ride Cup1 St
F#2	1420	Tambourine1 Hit
G2	2493	Ride Cup1 St
G#2	1461	Cowbell1
A2	2509	Ride Mono
A#2	1451	Vibraslap
B2	2490	Ride2 L
C3	1363	Bongo Hi 1Finger 1-2
C#3	1376	Bongo Lo 3Finger 1-2
D3	1335	Conga Hi Tip
D#3	1341	Conga Hi Slp Open
E3	1339	Conga Hi Open 2
F3	1381	Timbale Hi1-3
F#3	1385	Timbale Lo1-2
G3	1429	Agogo Hi
G#3	1430	Agogo Lo
A3	1427	Tmbourim Finger
A#3	1427	Tmbourim Finger
B3	1457	HandClap L
C4	1457	HandClap L
C#4	1432	Guiro Long
D4	1432	Guiro Long
D#4	885	Udo Finger
E4	866	Tabla Bya
F4	1335	Conga Hi Tip
F#4	886	Udo High
G4	886	Udo High
G#4	885	Udo Finger
A4	130	Finger Cymbal
A#4	868	Tabla Mute
B4	1467	Sleigh Bell
C5	1468	Wind Chime
C#5	1341	Conga Hi Slp Open
D5	1359	Tumba Tip
D#5	1359	Tumba Tip
E5	2655	Electric Bass FX 08
F5	1359	Tumba Tip
F#5	2648	Electric Bass FX 01
G5	1357	Tumba Open
G#5	2653	Electric Bass FX 06
A5	2535	AcousticGtr FX04 St
A#5	887	Udo Low
B5	865	Djembe Combi
C6	1358	Tumba Slap

PRE 54 Scratches

Note	Wave Number	Wave Name
C0	1312	Scratch H
C#0	1313	Scratch L
D0	1314	Scratch Down
D#0	1315	Scratch Hi F
E0	1316	Scratch Hi R
F0	1317	Scratch Lo F
F#0	1318	Scratch Lo R
G0	1319	Scratch Bd F
G#0	1320	Scratch Bd R
A0	1321	Scratch Sd F
A#0	1322	Scratch Sd R
B0	1323	Scratch Vo F
C1	1312	Scratch H
C#1	1313	Scratch L
D1	1314	Scratch Down
D#1	1315	Scratch Hi F
E1	1316	Scratch Hi R
F1	1317	Scratch Lo F
F#1	1318	Scratch Lo R
G1	1319	Scratch Bd F
G#1	1320	Scratch Bd R
A1	1321	Scratch Sd F
A#1	1322	Scratch Sd R
B1	1323	Scratch Vo F
C2	1324	Scratch Vo R
C#2	1325	Scratch Stop
D2	1326	Scratch Spin
D#2	1327	Scratch Hip
E2	1328	Scratch Hip2
F2	1331	Scratch Combi
F#2	1332	Scratch Combi2
G2	1333	Scratch Combi3
G#2	1334	Scratch Combi4
A2	1312	Scratch H
A#2	1313	Scratch L
B2	1314	Scratch Down
C3	1315	Scratch Hi F
C#3	1316	Scratch Hi R
D3	1317	Scratch Lo F
D#3	1318	Scratch Lo R
E3	1319	Scratch Bd F
F3	1320	Scratch Bd R
F#3	1321	Scratch Sd F
G3	1322	Scratch Sd R
G#3	1323	Scratch Vo F
A3	1324	Scratch Vo R
A#3	1325	Scratch Stop
B3	1326	Scratch Spin
C4	1327	Scratch Hip
C#4	1328	Scratch Hip2
D4	1331	Scratch Combi
D#4	1332	Scratch Combi2
E4	1333	Scratch Combi3
F4	1334	Scratch Combi4
F#4	1312	Scratch H
G4	1313	Scratch L
G#4	1314	Scratch Down
A4	1315	Scratch Hi F
A#4	1316	Scratch Hi R
B4	1317	Scratch Lo F
C5	1318	Scratch Lo R
C#5	1319	Scratch Bd F
D5	1320	Scratch Bd R
D#5	1321	Scratch Sd F
E5	1322	Scratch Sd R
F5	1323	Scratch Vo F
F#5	1324	Scratch Vo R
G5	1325	Scratch Stop
G#5	1326	Scratch Spin
A5	1327	Scratch Hip
A#5	1328	Scratch Hip2
B5	1331	Scratch Combi
C6	1332	Scratch Combi2

PRE 55 Acoustic Snares

Note	Wave Number	Wave Name
C0	1768	Sd Normal 1St
C#0	1769	Sd Normal 2St
D0	1770	Sd Normal 3St
D#0	1771	Sd Normal 4St
E0	1786	Sd Funk 1St
F0	1787	Sd Funk 2St
F#0	1788	Sd Funk 3St
G0	1797	Sd Funk Ay St
G#0	1804	Sd Basic 1St
A0	1805	Sd Basic 2St
A#0	1806	Sd Basic 3St
B0	1821	Sd SonA 1St
C1	1822	Sd SonA 2St
C#1	1823	Sd SonA 3St
D1	1824	Sd SonA 4St
D#1	1839	Sd Blues 1St
E1	1840	Sd Blues 2St
F1	1841	Sd Blues 3St
F#1	1854	Sd BluesHeart 1St
G1	1855	Sd BluesHeart 2St
G#1	1856	Sd BluesHeart 3St
A1	1871	Sd Tight 1St
A#1	1872	Sd Tight 2St
B1	1873	Sd Tight 3St
C2	1874	Sd Tight 4St
C#2	1886	Sd Hip 1St
D2	1887	Sd Hip 2St
D#2	1894	Sd Rock Open1 St
E2	1897	Sd Rock Mute1 St
F2	1900	Sd Rock Rim1 St
F#2	1903	Sd Rock Open2 St
G2	1906	Sd Rock Mute2 St
G#2	1909	Sd Rock Rim2 St
A2	1912	Sd Rock Flam St
A#2	1894	Sd Rock Open1 St
B2	1897	Sd Rock Mute1 St
C3	1900	Sd Rock Rim1 St
C#3	1903	Sd Rock Open2 St
D3	1906	Sd Rock Mute2 St
D#3	1909	Sd Rock Rim2 St
E3	1912	Sd Rock Flam St
F3	1770	Sd Normal 3St
F#3	1797	Sd Funk Ay St
G3	1806	Sd Basic 3St
G#3	1823	Sd SonA 3St
A3	1856	Sd BluesHeart.3St
A#3	1873	Sd Tight 3St
B3	1882	Sd Tight 3R
C4	1682	Sd Bid St1-4
C#4	1702	Sd Soul St1-4
D4	1722	Sd Strong St1-4
D#4	1742	Sd Rng St1-4
E4	1919	Sd Mid Rim
F4	1920	Sd Ambience
F#4	2008	Sd Gate1
G4	2010	Sd LdwHMMono
G#4	2011	Sd BreakRim
A4	2012	Sd Dry
A#4	2013	Sd Heavy
B4	2014	Sd GM
C5	1942	Sd PowerB 1-5St
C#5	1966	Sd PowerC 1-5St
D5	1990	Sd PowerD 1-4St
D#5	2014	Sd GM
E5	2046	Sd Brush Soft St
F5	2049	Sd Brush Med St
F#5	2052	Sd Brush vari St
G5	2061	Sd Brush SwirAtt St
G#5	2065	Sd Orch1 S St
A5	2073	Sd Orch2 SwSt
A#5	2082	Sd Orch Roll St
B5	2066	Sd Orch1 H St
C6	2049	Sd Brush Med St

PRE 56 GroupedStereo Snares

Note	Wave Number	Wave Name
C0	1762	Sd Normal St1-4
C#0	1763	Sd Normal St1-3
D0	1764	Sd Normal St2-4
D#0	1765	Sd Normal St1-2
E0	1766	Sd Normal St2-3
F0	1767	Sd Normal St3-4
F#0	1768	Sd Normal 1St
G0	1769	Sd Normal 2St
G#0	1770	Sd Normal 3St
A0	1771	Sd Normal 4St
A#0	1782	Sd Funk St1-3
B0	1783	Sd Funk St1-2
C1	1784	Sd Funk St2-3
C#1	1785	Sd Funk St1/3
D1	1786	Sd Funk 1St
D#1	1787	Sd Funk 2St
E1	1788	Sd Funk 3St
F1	1797	Sd Funk Ay St
F#1	1800	Sd Basic St1-3
G1	1801	Sd Basic St1-2
G#1	1802	Sd Basic St2-3
A1	1803	Sd Basic St1/3
A#1	1804	Sd Basic 1St
B1	1805	Sd Basic 2St
C2	1806	Sd Basic 3St
C#2	1815	Sd SonA St1-4
D2	1816	Sd SonA St1-3
D#2	1817	Sd SonA St2-4
E2	1818	Sd SonA St1-2
F2	1819	Sd SonA St2-3
F#2	1820	Sd SonA St3-4
G2	1821	Sd SonA 1St
G#2	1822	Sd SonA 2St
A2	1823	Sd SonA 3St
A#2	1824	Sd SonA 4St
B2	1835	Sd Blues St1-3
C3	1836	Sd Blues St1-2
C#3	1837	Sd Blues St2-3
D3	1838	Sd Blues St1/3
D#3	1839	Sd Blues 1St
E3	1840	Sd Blues 2St
F3	1841	Sd Blues 3St
F#3	1850	Sd BluesHeart St1-3
G3	1851	Sd BluesHeart St1-2
G#3	1852	Sd BluesHeart St2-3
A3	1853	Sd BluesHeart St1/3
A#3	1854	Sd BluesHeart 1St
B3	1855	Sd BluesHeart 2St
C4	1856	Sd BluesHeart 3St
C#4	1865	Sd Tight St1-4
D4	1866	Sd Tight St1-3
D#4	1867	Sd Tight St2-4
E4	1868	Sd Tight St1-2
F4	1869	Sd Tight St2-3
F#4	1870	Sd Tight St3-4
G4	1871	Sd Tight 1St
G#4	1872	Sd Tight 2St
A4	1873	Sd Tight 3St
A#4	1874	Sd Tight 4St
B4	1927	Sd PowerA 1St
C5	1930	Sd PowerA 2St
C#5	1933	Sd PowerA 3St
D5	1936	Sd PowerA 4St
D#5	1939	Sd PowerA 5St
E5	1948	Sd PowerB 1St
F5	1951	Sd PowerB 2St
F#5	1954	Sd PowerB 3St
G5	1957	Sd PowerB 4St
G#5	1960	Sd PowerB 5St
A5	1966	Sd PowerC 1-5St
A#5	1990	Sd PowerD 1-4St
B5	1835	Sd Blues St1-3
C6	1850	Sd BluesHeart St1-3

PRE 57 All Kicks

Note	Wave Number	Wave Name
C0	1527	Bd Normal St1-2
C#0	1500	Bd Snap 1-2
D0	1510	Bd Tight 1
D#0	1530	Bd Normal L1-2
E0	1536	Bd Funk St1-2
F0	1518	Bd Ambience 1-2
F#0	1538	Bd Funk 2St
G0	1545	Bd High St
G#0	1548	Bd Low St
A0	1551	Bd H Son St
A#0	1554	Bd L Son St
B0	1557	Bd Funk Son St
C1	1560	Bd Rock1 St
C#1	1563	Bd Rock2 St
D1	1566	Bd Dry1
D#1	1567	Bd Dry2
E1	1568	Bd Pop
F1	1569	Bd Var1
F#1	1570	Bd Var2
G1	1571	Bd Room1
G#1	1572	Bd Room2
A1	1573	Bd Room3
A#1	1610	Bd Gate
B1	1611	Bd FX Gate
C2	1586	Bd PowerA 1-2St
C#2	1595	Bd PowerB 1-2St
D2	1583	Bd FK Jazz St
D#2	1615	Bd T9-4
E2	1616	Bd T9 Hd1
F2	1617	Bd T9 Hd2
F#2	1618	Bd T9 Hd3
G2	1619	Bd T8-1
G#2	1620	Bd T8-2
A2	1621	Bd T8-3
A#2	1622	Bd AnSm
B2	1623	Bd AnCR
C3	1624	Bd Human1
C#3	1625	Bd Human2
D3	1626	Bd Blip
D#3	1627	Bd BlpHd
E3	1628	Bd Jungle1
F3	1629	Bd Jungle2
F#3	1630	Bd Jungle3
G3	1631	Bd D&B1
G#3	1632	Bd D&B2
A3	1633	Bd R&B1
A#3	1634	Bd R&B2
B3	1635	Bd Hip Deep
C4	1636	Bd Break Deep
C#4	1637	Bd Break1
D4	1638	Bd Break2
D#4	1639	Bd Break Heavy
E4	1640	Bd Break Hard
F4	1641	Bd Distortion1
F#4	1642	Bd Distortion2
G4	1643	Bd Distortion3
G#4	1644	Bd Distortion4
A4	1645	Bd Distortion5
A#4	1646	Bd Distortion RM
B4	1647	Bd +HH
C5	1648	Bd FxHammer
C#5	1649	Bd ZapHard
D5	1650	Bd ZapMid
D#5	1651	Bd Sustain
E5	1652	Bd TekPower
F5	1653	Bd Hard Long
F#5	1654	Bd Analog Tight
G5	1655	Bd AnaHard
G#5	1656	Bd Lo-Fi
A5	1657	Bd ThickSkin
A#5	1658	Bd Slimy
B5	1679	Bd HipHop8
C6	1681	Bd HipHop10

PRE 58 Dance Kicks

Note	Wave Number	Wave Name
C0	1612	Bd T9-1
C#0	1612	Bd T9-1
D0	1613	Bd T9-2
D#0	1614	Bd T9-3
E0	1614	Bd T9-3
F0	1615	Bd T9-4
F#0	1616	Bd T9 Hd1
G0	1617	Bd T9 Hd2
G#0	1618	Bd T9 Hd3
A0	1618	Bd T9 Hd3
A#0	1653	Bd Hard Long
B0	1623	Bd AnCR
C1	1612	Bd T9-1
C#1	1613	Bd T9-2
D1	1614	Bd T9-3
D#1	1615	Bd T9-4
E1	1616	Bd T9 Hd1
F1	1617	Bd T9 Hd2
F#1	1618	Bd T9 Hd3
G1	1619	Bd T8-1
G#1	1620	Bd T8-2
A1	1621	Bd T8-3
A#1	1659	Bd Elec1
B1	1623	Bd AnCR
C2	1624	Bd Human1
C#2	1659	Bd Elec1
D2	1626	Bd Blip
D#2	1627	Bd BlpHd
E2	1661	Bd Elec3
F2	1666	Bd ElecFX1
F#2	1667	Bd ElecFX2
G2	1668	Bd ElecGate
G#2	1669	Bd ElecClick
A2	1670	Bd ElecPower1
A#2	1634	Bd R&B2
B2	1635	Bd Hip Deep
C3	1636	Bd Break Deep
C#3	1637	Bd Break1
D3	1671	Bd ElecPower2
D#3	1639	Bd Break Heavy
E3	1640	Bd Break Hard
F3	1641	Bd Distortion1
F#3	1642	Bd Distortion2
G3	1643	Bd Distortion3
G#3	1644	Bd Distortion4
A3	1645	Bd Distortion5
A#3	1660	Bd Elec2
B3	1663	Bd ElecComp1
C4	1648	Bd FxHammer
C#4	1649	Bd ZapHard
D4	1650	Bd ZapMid
D#4	1651	Bd Sustain
E4	1652	Bd TekPower
F4	1653	Bd Hard Long
F#4	1654	Bd Analog Tight
G4	1655	Bd AnaHard
G#4	1664	Bd ElecComp2
A4	1665	Bd ElecComp3
A#4	1658	Bd Slimy
B4	1610	Bd Gate
C5	1611	Bd FX Gate
C#5	1672	Bd HipHop1
D5	1673	Bd HipHop2
D#5	1674	Bd HipHop3
E5	1675	Bd HipHop4
F5	1676	Bd HipHop5
F#5	1677	Bd HipHop6
G5	1678	Bd HipHop7
G#5	1679	Bd HipHop8
A5	1680	Bd HipHop9
A#5	1681	Bd HipHop10
B5	1653	Bd Hard Long
C6	1654	Bd Analog Tight

PRE 59 Arabic Mixed Kit

Note	Wave Number	Wave Name
C0	1468	Wind Chime
C#0	2046	Sd Brush Soft St
D0	2058	Sd Brush Swir St
D#0	2049	Sd Brush Med St
E0	2061	Sd Brush SwirAtt St
F0	2042	Sd LiveRoll St
F#0	1448	Castanet
G0	1768	Sd Normal 1St
G#0	1446	Stick1
A0	1613	Bd T9-2
A#0	1800	Sd Basic St1-3
B0	1545	Bd High St
C1	1527	Bd Normal St1-2
C#1	1782	Sd Funk St1-3
D1	1682	Sd Bld St1-4
D#1	1456	HandClap St
E1	1702	Sd Soul St1-4
F1	2375	Tom Rock Low St
F#1	2174	HH Closed 1-4St
G1	2371	Tom Rock Mid St
G#1	2194	HH Pedal 1-3St
A1	2363	Tom Floor St
A#1	2210	HH Open 1-2St
B1	2359	Tom Low St
C2	2355	Tom Mid St
C#2	2461	Crash2 St
D2	2351	Tom Hi St
D#2	2210	HH Open 1-2St
E2	2525	Reverse Cymbal
F2	1385	Timbale Lo1-2
F#2	1339	Conga Hi Open 2
G2	1381	Timbale Hi1-3
G#2	1341	Conga Hi Slp Open
A2	1419	Tambourine1 Sw
A#2	1357	Tumba Open
B2	1461	Cowbell1
C3	1449	Clave
C#3	1363	Bongo Hi 1Finger 1-2
D3	1450	Wood Block
D#3	1376	Bongo Lo 3Finger 1-2
E3	1450	Wood Block
F3	889	Dohol Low
F#3	1399	Cabasa 1-2
G3	890	Dohol High
G#3	1406	Shaker 1
A3	1448	Castanet
A#3	1396	Maracas Sw
B3	1448	Castanet
C4	898	Twaisat3
C#4	896	Twaisat
D4	897	Twaisat2
D#4	899	Twaisat4
E4	899	Twaisat4
F4	870	Small Tabla Dom
F#4	891	Barasim Dom
G4	871	Small Tabla Snap
G#4	892	Barasim Sak
A4	872	Small Tabla Sak
A#4	893	Barasim Tak
B4	873	Small Tabla Tak
C5	874	Big Tabla Dom
C#5	894	Segal Dom
D5	875	Big Tabla Tak
D#5	895	Segal Tak
E5	876	Big Tabla Sak
F5	877	Tabla Dom
F#5	878	Tabla Tak1
G5	884	Tabla Tremoro
G#5	879	Tabla Tak2
A5	880	Tabla Tik1
A#5	883	Tabla Sak1
B5	882	Tabla Tik3
C6	881	Tabla Tik2

PRE 60 Belly Dance Kit

Note	Wave Number	Wave Name
C0	881	Tabla Tik2
C#0	861	Wataiko
D0	862	Djembe Edge
D#0	863	Djembe Mute
E0	864	Djembe Open
F0	865	Djembe Combi
F#0	866	Tabla Bya
G0	867	Tabla Nah
G#0	868	Tabla Mute
A0	869	Tabla Combi
A#0	870	Small Tabla Dom
B0	870	Small Tabla Dom
C1	1653	Bd Hard Long
C#1	1612	Bd T9-1
D1	2098	Sd T9-2
D#1	1471	Electric Clap1
E1	1732	Sd Strong L1-4
F1	2456	Tom Dist Lo
F#1	2324	HH Closed T9
G1	2455	Tom Dist Hi
G#1	2326	HH Closed T8-1
A1	2452	Tom Syn1
A#1	2325	HH Open T9
B1	2453	Tom Syn2
C2	2127	Sd Hip1
C#2	2466	Crash4
D2	2123	Sd D&B4
D#2	2333	HH Closed Break
E2	2525	Reverse Cymbal
F2	1385	Timbale Lo1-2
F#2	1339	Conga Hi Open 2
G2	1381	Timbale Hi1-3
G#2	1341	Conga Hi Slp Open
A2	1419	Tambourine1 Sw
A#2	1357	Tumba Open
B2	1461	Cowbell1
C3	1449	Clave
C#3	1363	Bongo Hi 1Finger 1-2
D3	1450	Wood Block
D#3	1376	Bongo Lo 3Finger 1-2
E3	1450	Wood Block
F3	889	Dohol Low
F#3	1399	Cabasa 1-2
G3	890	Dohol High
G#3	1406	Shaker 1
A3	1448	Castanet
A#3	1396	Maracas Sw
B3	1448	Castanet
C4	898	Twaisat3
C#4	896	Twaisat
D4	897	Twaisat2
D#4	899	Twaisat4
E4	899	Twaisat4
F4	870	Small Tabla Dom
F#4	891	Barasim Dom
G4	871	Small Tabla Snap
G#4	892	Barasim Sak
A4	872	Small Tabla Sak
A#4	893	Barasim Tak
B4	873	Small Tabla Tak
C5	874	Big Tabla Dom
C#5	894	Segal Dom
D5	875	Big Tabla Tak
D#5	895	Segal Tak
E5	876	Big Tabla Sak
F5	877	Tabla Dom
F#5	878	Tabla Tak1
G5	884	Tabla Tremoro
G#5	879	Tabla Tak2
A5	880	Tabla Tik1
A#5	883	Tabla Sak1
B5	882	Tabla Tik3
C6	881	Tabla Tik2

PRE 61 Dance Snares

Note	Wave Number	Wave Name
C0	2141	Sd FX1
C#0	2142	Sd FX2
D0	2143	Sd FX3
D#0	2144	Sd FX4
E0	2146	Sd Dist
F0	2147	Sd Cut
F#0	2148	Sd Garg H
G0	2149	Sd Garg L
G#0	2150	Sd FM
A0	2152	Sd Syn
A#0	2156	Sd Hammer
B0	2157	Sd Lo-Fi
C1	2097	Sd T9-1
C#1	2098	Sd T9-2
D1	2099	Sd T9-3
D#1	2100	Sd T9-4
E1	2101	Sd T9-5
F1	2102	Sd T9Gate
F#1	2104	Sd T8-1
G1	2105	Sd T8-2
G#1	2106	Sd T8-3
A1	2107	Sd T8-4
A#1	2108	Sd T8-5
B1	2110	Sd AnSm
C2	2112	Sd AnCR
C#2	2114	Sd Human1
D2	2116	Sd Jungle1
D#2	2117	Sd Jungle2
E2	2118	Sd Jungle3
F2	2119	Sd JungleFX
F#2	2120	Sd D&B1
G2	2121	Sd D&B2
G#2	2122	Sd D&B3
A2	2123	Sd D&B4
A#2	2124	Sd R&B1
B2	2125	Sd R&B1 Rim
C3	2126	Sd R&B2
C#3	2127	Sd Hip1
D3	2128	Sd Hip2
D#3	2129	Sd Hip3
E3	2130	Sd Hip Gate
F3	2131	Sd Hip Rim1
F#3	2132	Sd Hip Rim2
G3	2133	Sd Hip Rim3
G#3	2134	Sd Hip Rim4
A3	2135	Sd Hip Rim5
A#3	2137	Sd Break2
B3	2139	Sd Break Heavy
C4	2085	Sd Elec1
C#4	2086	Sd Elec2
D4	2087	Sd Elec3
D#4	2088	Sd Elec4
E4	2089	Sd Elec5
F4	2090	Sd Elec6
F#4	2091	Sd Elec7
G4	2092	Sd Elec8
G#4	2093	Sd Elec9
A4	2094	Sd Elec10
A#4	2095	Sd Elec11
B4	2096	Sd Elec12
C5	2085	Sd Elec1
C#5	2105	Sd T8-2
D5	2087	Sd Elec3
D#5	2088	Sd Elec4
E5	2089	Sd Elec5
F5	2090	Sd Elec6
F#5	2091	Sd Elec7
G5	2085	Sd Elec1
G#5	2092	Sd Elec8
A5	2094	Sd Elec10
A#5	2095	Sd Elec11
B5	2096	Sd Elec12
C6	2099	Sd T9-3

PRE 62 Special SFXs

Note	Wave Number	Wave Name
C0	1018	Mini Blip2
C#0	1017	Mini Blip1
D0	1019	Mini Blip3
D#0	1020	Mini Blip4
E0	1021	Mini Blip5
F0	1022	Mini Blip6
F#0	1270	Bell FX1
G0	1271	Bell FX2
G#0	1279	Electric Perc4
A0	1281	Electric Perc6
A#0	1290	Electric Perc15
B0	1280	Electric Perc5
C1	1277	Electric Perc2
C#1	1278	Electric Perc3
D1	1282	Electric Perc7
D#1	1283	Electric Perc8
E1	1284	Electric Perc9
F1	1285	Electric Perc10
F#1	1289	Electric Perc14
G1	1288	Electric Perc13
G#1	1203	Neo Seq Em-3
A1	1089	Spectrum1
A#1	1091	Spectrum3
B1	1090	Spectrum2
C2	1209	Whisper Seq Bb
C#2	1259	Digi Voice Mod
D2	1197	Moving Chime St
D#2	1183	Engine Room St
E2	1181	Raspberry
F2	1186	DigiHeli
F#2	1167	Hop FX1
G2	1113	Willow St
G#2	1116	Anemone St
A2	1119	Magnitude St
A#2	1157	Radio Noise
B2	1165	Quiek
C3	1174	Stab Giant
C#3	1143	HH Hit
D3	1175	Stab Hard
D#3	1176	Stab Organ2
E3	1177	Stab Aah
F3	1178	Hit Uhh
F#3	1179	Hit Orchestra2
G3	1171	Hit Orchestra1
G#3	1172	Hit Brass
A3	1127	Orchestra Hit1 St
A#3	1130	Orchestra Hit2 St
B3	560	Brass Sect Fall
C4	335	Play FX Mix
C#4	335	Play FX Mix
D4	2638	ElectricGtr FX23
D#4	2642	Acoustic Bass FX04
E4	2643	Acoustic Bass FX05
F4	2639	Acoustic Bass FX01
F#4	1312	Scratch H
G4	1313	Scratch L
G#4	1314	Scratch Down
A4	1315	Scratch Hi F
A#4	1325	Scratch Stop
B4	1295	Tape Rewind
C5	1268	Ripper
C#5	1273	Noise Burst
D5	1274	Zap1
D#5	1275	Zap2
E5	1291	Hi Q1
F5	1292	Hi Q2
F#5	1294	Bomb
G5	1296	FxGun1
G#5	1214	Motion Beam
A5	1110	Birch St
A#5	1044	Tri Wave
B5	1012	FM Bass2
C6	1026	FM Metal2

PRE 63 Synthetic Kit

Note	Wave Number	Wave Name
C0	1660	Bd Elec2
C#0	1325	Scratch Stop
D0	2059	Sd Brush Swir L
D#0	2051	Sd Brush Med R
E0	2058	Sd Brush Swir St
F0	2045	Sd Roll Mono
F#0	1016	FM Bass6
G0	1304	Seashore
G#0	1279	Electric Perc4
A0	1665	Bd ElecComp3
A#0	1739	Sd Strong R2
B0	1660	Bd Elec2
C1	1658	Bd Slimy
C#1	1389	Timbale Paila H
D1	1915	Sd Piccolo
D#1	1470	Clap AnSm
E1	2094	Sd Elec10
F1	991	Mg Bass2
F#1	1292	Hi Q2
G1	991	Mg Bass2
G#1	1282	Electric Perc7
A1	2451	Tom T8
A#1	2329	HH Open T8-2
B1	2451	Tom T8
C2	2451	Tom T8
C#2	2465	Crash3
D2	2451	Tom T8
D#2	2510	Ride Cup Mono
E2	2510	Ride Cup Mono
F2	2510	Ride Cup Mono
F#2	1321	Scratch Sd F
G2	2496	Ride Cup1 RL
G#2	1282	Electric Perc7
A2	2465	Crash3
A#2	1149	Hi-Lo
B2	2516	China2
C3	939	Ring Mod
C#3	1283	Electric Perc8
D3	939	Ring Mod
D#3	1282	Electric Perc7
E3	1286	Electric Perc11
F3	1392	Paila H
F#3	1392	Paila H
G3	1167	Hop FX1
G#3	1168	Hop FX2
A3	1312	Scratch H
A#3	1315	Scratch Hi F
B3	1275	Zap2
C4	1166	LFO Seq
C#4	1166	LFO Seq
D4	969	Mini Bass3a
D#4	1165	Quiek
E4	1182	Digi Breath
F4	1186	DigiHeli
F#4	1282	Electric Perc7
G4	1027	FM Organ1
G#4	903	Tibetan Bowl
A4	903	Tibetan Bowl
A#4	894	Segal Dom
B4	1185	Engine Room R
C5	1283	Electric Perc8
C#5	272	Steel Slide St
D5	1018	Mini Blip2
D#5	1090	Spectrum2
E5	1021	Mini Blip5
F5	1093	Noise
F#5	1631	Bd D&B1
G5	1090	Spectrum2
G#5	1122	SabreTone
A5	1289	Electric Perc14
A#5	1283	Electric Perc8
B5	1186	DigiHeli
C6	1468	Wind Chime

PRE 64 SFX Kit

Note	Wave Number	Wave Name
C0	926	Fat Saw Mn
C#0	1329	Scratch Attack
D0	1090	Spectrum2
D#0	959	3o3 Saw2
E0	1299	TurnTable
F0	2045	Sd Roll Mono
F#0	1016	FM Bass6
G0	1295	Tape Rewind
G#0	1280	Electric Perc5
A0	1664	Bd ElecComp2
A#0	1762	Sd Normal St1-4
B0	1658	Bd Slimy
C1	1660	Bd Elec2
C#1	969	Mini Bass3a
D1	1850	Sd BluesHeart St1-3
D#1	960	3o3 Square
E1	1831	Sd SonA 3L
F1	2455	Tom Dist Hi
F#1	1186	DigiHeli
G1	2455	Tom Dist Hi
G#1	1277	Electric Perc2
A1	2455	Tom Dist Hi
A#1	2329	HH Open T8-2
B1	2455	Tom Dist Hi
C2	2455	Tom Dist Hi
C#2	2465	Crash3
D2	2455	Tom Dist Hi
D#2	2495	Ride Cup1 R
E2	2492	Ride2 RL
F2	2511	Ride Cup Mono2
F#2	1315	Scratch Hi F
G2	2518	Splash L
G#2	965	Mini Bass1
A2	2457	Crash1 St
A#2	1183	Engine Room St
B2	2496	Ride Cup1 RL
C3	945	Sync LFO
C#3	949	P5 SawDown 0 dg
D3	932	OB Strings
D#3	1763	Sd Normal St1-3
E3	1286	Electric Perc11
F3	947	PWM Slow
F#3	1166	LFO Seq
G3	1138	BigSyn
G#3	1138	BigSyn
A3	1179	Hit Orchestra2
A#3	870	Small Tabla Dom
B3	1047	Digi 03
C4	1047	Digi 03
C#4	1045	Digi 01
D4	1045	Digi 01
D#4	1169	Sonar1
E4	1175	Stab Hard
F4	1183	Engine Room St
F#4	1193	Chatter
G4	1160	Hoo
G#4	901	Mondira
A4	901	Mondira
A#4	202	Rotor
B4	1181	Raspberry
C5	1186	DigiHeli
C#5	960	3o3 Square
D5	1168	Hop FX2
D#5	1084	DigiBell3
E5	1293	Vox Hit Rev
F5	1291	Hi Q1
F#5	1295	Tape Rewind
G5	1297	FxGun2
G#5	1296	FxGun1
A5	1298	Thunder
A#5	1300	Police
B5	1294	Bomb
C6	1294	Bomb

GM Drum Stereo GM Kit

Note	Wave Number	Wave Name
C0	1449	Clave
C#0	2046	Sd Brush Soft St
D0	2058	Sd Brush Swir St
D#0	2049	Sd Brush Med St
E0	2061	Sd Brush SwirAtt St
F0	2042	Sd LiveRoll St
F#0	1448	Castanet
G0	1768	Sd Normal 1St
G#0	1446	Stick1
A0	1536	Bd Funk St1-2
A#0	1802	Sd Basic St2-3
B0	1545	Bd High St
C1	1527	Bd Normal St1-2
C#1	2031	Sd Closed Rim St
D1	1762	Sd Normal St1-4
D#1	1469	Clap T9
E1	1801	Sd Basic St1-2
F1	2363	Tom Floor St
F#1	2174	HH Closed 1-4St
G1	2359	Tom Low St
G#1	2197	HH Pedal 3 St
A1	2359	Tom Low St
A#1	2212	HH Open 2St
B1	2355	Tom Mid St
C2	2355	Tom Mid St
C#2	2461	Crash2 St
D2	2351	Tom Hi St
D#2	2485	Ride1 St
E2	2512	China St
F2	2493	Ride Cup1 St
F#2	1419	Tambourine1 Sw
G2	2517	Splash St
G#2	1462	Cowbell2
A2	2464	Crash2 RL
A#2	1451	Vibraslap
B2	2488	Ride1 RL
C3	1363	Bongo Hi 1Finger 1-2
C#3	1376	Bongo Lo 3Finger 1-2
D3	1335	Conga Hi Tip
D#3	1339	Conga Hi Open 2
E3	1357	Tumba Open
F3	1381	Timbale Hi1-3
F#3	1385	Timbale Lo1-2
G3	1429	Agogo Hi
G#3	1430	Agogo Lo
A3	1399	Cabasa1-2
A#3	1397	Maracas Slur
B3	1452	Whistle
C4	1452	Whistle
C#4	1433	Guiro Short
D4	1432	Guiro Long
D#4	1449	Clave
E4	1450	Wood Block
F4	1450	Wood Block
F#4	1362	Cuica Hi
G4	1361	Cuica Lo
G#4	1455	Triangle Mute
A4	1454	Triangle Open
A#4	1406	Shaker 1
B4	1467	Sleigh Bell
C5	1468	Wind Chime
C#5	1842	Sd Blues L1-3
D5	1865	Sd Tight St1-4
D#5	1858	Sd BluesHeart R1-3
E5	1885	Sd Hip St1-2
F5	1548	Bd Low St
F#5	2010	Sd LdwHMono
G5	1633	Bd R&B1
G#5	2013	Sd Heavy
A5	1571	Bd Room1
A#5	1920	Sd Ambience
B5	1557	Bd Funk Son St
C6	1572	Bd Room2

Waveform List

No	Category	Name	No	Category	Name	No	Category	Name	No	Category	Name	No	Category	Name	No	Category	Name
1	Ap	CF3 Stretch Sw St	101	Ep	DX Body Med	201	Or	Clack 2	301	Gt	Clean Hammer On	401	St	Violin St Of	501	St	Hard Ensemble R-
2	Ap	CF3 Stretch Sw Mn	102	Ep	DX Body Hard	202	Or	Rotor	302	Gt	Clean Slap	402	St	Violin L Of	502	St	Hard Ensemble St Of
3	Ap	CF3 Stretch Soft St+	103	Ep	DX Attack1	203	Or	Rotor Whistle	303	Gt	Clean Slide	403	St	Violin R Of	503	St	Hard Ensemble L Of
4	Ap	CF3 Stretch Soft Mn	104	Ep	DX Attack2	204	Or	Rotor Grit1	304	Gt	Clean Harmonics	404	St	Viola St	504	St	Hard Ensemble R Of
5	Ap	CF3 Stretch Soft St+	105	Ep	DX Attack3	205	Or	Rotor Grit2	305	Gt	Clean Mute	405	St	Viola L	505	St	OrchStrgs Soft St
6	Ap	CF3 Stretch Soft Mn+	106	Ep	DX Attack4	206	Or	Compact Electronic	306	Gt	Clean Dead	406	St	Viola R	506	St	OrchStrgs Soft St+
7	Ap	CF3 Stretch Soft St-	107	Ep	DX Attack5	207	Or	Compact Electronic-	307	Gt	Clean FX	407	St	Viola St+	507	St	OrchStrgs Soft St-
8	Ap	CF3 Stretch Soft Mn-	108	Kb	Clav1	208	Or	Portable Electronic	308	Gt	60s Clean Open Soft	408	St	Viola L+	508	St	OrchStrgs Soft L+
9	Ap	CF3 Stretch Med St	109	Kb	Clav1+	209	Or	Portable Electronic-	309	Gt	60s Clean Open Med	409	St	Viola R+	509	St	OrchStrgs Soft L+
10	Ap	CF3 Stretch Med Mn	110	Kb	Clav1-	210	Or	Pipe Organ1 St	310	Gt	60s Clean Open Hard	410	St	Viola St-	510	St	OrchStrgs Soft L-
11	Ap	CF3 Stretch Med St+	111	Kb	Clav2	211	Or	Pipe Organ1 L	311	Gt	60s Clean Open Sw	411	St	Viola L-	511	St	OrchStrgs Soft R-
12	Ap	CF3 Stretch Med Mn+	112	Kb	Clav2+	212	Or	Pipe Organ1 R	312	Gt	60s Clean Open Sw Kb	412	St	Viola R-	512	St	OrchStrgs Soft R+
13	Ap	CF3 Stretch Med St-	113	Kb	Clav2-	213	Or	Pipe Organ2	313	Gt	60s Clean Open Sw2	413	St	Viola St Of	513	St	OrchStrgs Soft R-
14	Ap	CF3 Stretch Med Mn-	114	Kb	Clav3	214	Or	Pipe Organ3 St	314	Gt	60s Clean Dead	414	St	Viola L Of	514	St	OrchStrgs Soft St Of
15	Ap	CF3 Stretch Hard St	115	Kb	Clav3+	215	Or	Pipe Organ3 L	315	Gt	60s Clean Mute	415	St	Viola R Of	515	St	OrchStrgs Soft L Of
16	Ap	CF3 Stretch Hard Mn	116	Kb	Clav3-	216	Or	Pipe Organ3 R	316	Gt	60s Clean Hammer On	416	St	Cello St	516	St	OrchStrgs Soft R Of
17	Ap	CF3 Stretch Hard St+	117	Kb	Clav Key Off	217	Or	Pipe Organ4	317	Gt	60s Clean Slide	417	St	Cello L	517	St	OrchStrgs Med St
18	Ap	CF3 Stretch Hard Mn+	118	Kb	Harpischord	218	Or	Pipe Organ5	318	Gt	60s Clean Harmonics	418	St	Cello R	518	St	OrchStrgs Med St+
19	Ap	CF3 Stretch Hard St-	119	Kb	Celesta	219	Or	Accordion	319	Gt	60s Clean FX	419	St	Cello St+	519	St	OrchStrgs Med St-
20	Ap	CF3 Stretch Hard Mn-	120	Cp	Vibraphone	220	Or	Tango Accordion	320	Gt	60s Clean Gt	420	St	Cello L+	520	St	OrchStrgs Med L
21	Ap	CF3 Key Off St	121	Cp	Marimba	221	Gt	Nylon Open Soft St	321	Gt	Jazz Guitar	421	St	Cello R+	521	St	OrchStrgs Med L+
22	Ap	CF3 Key Off L	122	Cp	Glockenspiel	222	Gt	Nylon Open Soft L	322	Gt	Vintage Amp1	422	St	Cello St-	522	St	OrchStrgs Med L-
23	Ap	CF3 Key Off R	123	Cp	Xylophone	223	Gt	Nylon Open Soft R	323	Gt	Vintage Amp2	423	St	Cello L-	523	St	OrchStrgs Med R
24	Ap	CF3 Flat Sw St	124	Cp	Tubular Bell	224	Gt	Nylon Open Med St	324	Gt	Neck Pickup	424	St	Cello R-	524	St	OrchStrgs Med R+
25	Ap	CF3 Flat Sw Mn	125	Cp	Bell	225	Gt	Nylon Open Med L	325	Gt	Distortion Open	425	St	Cello St Of	525	St	OrchStrgs Med R-
26	Ap	CF3 Flat Soft St	126	Cp	Bell St1	226	Gt	Nylon Open Med R	326	Gt	Distortion Harmonics	426	St	Cello L Of	526	St	OrchStrgs Med St Of
27	Ap	CF3 Flat Soft Mn	127	Cp	Bell St2	227	Gt	Nylon Open Hard St	327	Gt	Distortion Mute	427	St	Cello R Of	527	St	OrchStrgs Med L Of
28	Ap	CF3 Flat Soft St+	128	Cp	Brass Bell	228	Gt	Nylon Open Hard L	328	Gt	Overdrive Open	428	St	Contrabass St	528	St	OrchStrgs Med R Of
29	Ap	CF3 Flat Soft Mn+	129	Cp	Small Bell	229	Gt	Nylon Open Hard R	329	Gt	Overdrive Mute	429	St	Contrabass L	529	St	OrchStrgs Hard St
30	Ap	CF3 Flat Soft St-	130	Cp	Finger Cymbal	230	Gt	Nylon Open Sw St	330	Gt	Distortion FX	430	St	Contrabass R	530	St	OrchStrgs Hard St+
31	Ap	CF3 Flat Soft Mn-	131	Cp	Hand Bell	231	Gt	Nylon Open Sw L	331	Gt	Dist/Overdrive FX	431	St	Contrabass St+	531	St	OrchStrgs Hard St-
32	Ap	CF3 Flat Med St	132	Cp	Hibashi	232	Gt	Nylon Open Sw R	332	Gt	Feedback	432	St	Contrabass L+	532	St	OrchStrgs Hard L
33	Ap	CF3 Flat Med Mn	133	Cp	Stone Hard	233	Gt	Nylon Open Sw Kb St	333	Gt	Power Chord St	433	St	Contrabass R+	533	St	OrchStrgs Hard L+
34	Ap	CF3 Flat Med St+	134	Cp	Stone Soft	234	Gt	Nylon Open Sw Kb L	334	Gt	Power Chord Mono	434	St	Contrabass St-	534	St	OrchStrgs Hard L-
35	Ap	CF3 Flat Med Mn+	135	Cp	Wood Bell1	235	Gt	Nylon Open Sw Kb R	335	Gt	Play FX Mix	435	St	Contrabass L-	535	St	OrchStrgs Hard R
36	Ap	CF3 Flat Med St-	136	Cp	Wood Bell2	236	Gt	Nylon Dead Notes St	336	Gt	Power Chord FX St	436	St	Contrabass R-	536	St	OrchStrgs Hard R+
37	Ap	CF3 Flat Med Mn-	137	Cp	Timpani Sw St	237	Gt	Nylon Dead Notes L	337	Gt	Power Chord FX Mono	437	St	Contrabass St Of	537	St	OrchStrgs Hard R-
38	Ap	CF3 Flat Hard St	138	Cp	Timpani Soft St	238	Gt	Nylon Dead Notes R	338	Gt	Banjo	438	St	Contrabass L Of	538	St	OrchStrgs Hard St Of
39	Ap	CF3 Flat Hard Mn	139	Cp	Timpani Hard St	239	Gt	Nylon Mute St	339	Ba	Acoustic Med	439	St	Contrabass R Of	539	St	OrchStrgs Hard L Of
40	Ap	CF3 Flat Hard St+	140	Cp	Timpani Sw L	240	Gt	Nylon Mute L	340	Ba	Acoustic Hard	440	St	Solo Combi St	540	St	OrchStrgs Hard R Of
41	Ap	CF3 Flat Hard Mn+	141	Cp	Timpani Soft L	241	Gt	Nylon Mute R	341	Ba	Acoustic Harmonics	441	St	Solo Combi L	541	St	OrchStrgs Hard R Of
42	Ap	CF3 Flat Hard St-	142	Cp	Timpani Hard L	242	Gt	Nylon Hammer St	342	Ba	Acoustic Dead	442	St	Solo Combi R	542	Br	Brass Sect1 St
43	Ap	CF3 Flat Hard Mn-	143	Cp	Timpani Sw R	243	Gt	Nylon Hammer L	343	Ba	Acoustic FX1	443	St	Solo Combi St+	543	Br	Brass Sect1 St+
44	Ap	Brite Piano	144	Cp	Timpani Soft R	244	Gt	Nylon Hammer R	344	Ba	Acoustic FX2	444	St	Solo Combi L+	544	Br	Brass Sect1 St-
45	Ap	Brite Piano-	145	Cp	Timpani Hard R	245	Gt	Nylon Slide St	345	Ba	Acoustic Med+	445	St	Solo Combi R+	545	Br	Brass Sect1 L
46	Ap	CP70	146	Or	Rock Chorus Vibrato	246	Gt	Nylon Slide L	346	Ba	Acoustic Hard+	446	St	Solo Combi St-	546	Br	Brass Sect1 L+
47	Ap	CP70+	147	Or	Rock Percussion	247	Gt	Nylon Slide R	347	Ba	Acoustic Med-	447	St	Solo Combi L-	547	Br	Brass Sect1 L-
48	Ap	CP70-	148	Or	Rock2	248	Gt	Nylon Harmonics St	348	Ba	Acoustic Hard-	448	St	Solo Combi R-	548	Br	Brass Sect1 R-
49	Ep	EP1 Sw	149	Or	Rock2+	249	Gt	Nylon Harmonics L	349	Ba	Pick Open	449	St	Solo Combi St Of	549	Br	Brass Sect1 R+
50	Ep	EP1 Soft	150	Or	Rock2-	250	Gt	Nylon Harmonics R	350	Ba	Pick Harmonics	450	St	Solo Combi L Of	550	Br	Brass Sect1 R-
51	Ep	EP1 Soft+	151	Or	Jazz w/Percussion	251	Gt	Nylon FX St	351	Ba	Pick Mute	451	St	Solo Combi R Of	551	Br	Brass Sect1 St Of
52	Ep	EP1 Soft-	152	Or	Jazz w/Percussion-	252	Gt	Nylon FX L	352	Ba	Pick Dead	452	St	Solo Combi2 St	552	Br	Brass Sect1 St+ Of
53	Ep	EP1 Med	153	Or	Jazz+	253	Gt	Nylon FX R	353	Ba	Pick Open+	453	St	Solo Combi2 L	553	Br	Brass Sect1 St- Of
54	Ep	EP1 Med+	154	Or	Jazz-	254	Gt	Steel Open Soft St	354	Ba	Pick Mute+	454	St	Solo Combi2 R	554	Br	Brass Sect1 L Of
55	Ep	EP1 Med-	155	Or	Jazz-	255	Gt	Steel Open Soft L	355	Ba	Pick Open-	455	St	Solo Combi2 St Of	555	Br	Brass Sect1 L+ Of
56	Ep	EP1 Hard	156	Or	Full Draw	256	Gt	Steel Open Soft R	356	Ba	Pick Mute-	456	St	Solo Combi2 L Of	556	Br	Brass Sect1 L- Of
57	Ep	EP1 Hard+	157	Or	Full Draw+	257	Gt	Steel Open Med St	357	Ba	Finger Med	457	St	Solo Combi2 R Of	557	Br	Brass Sect1 R+ Of
58	Ep	EP1 Hard-	158	Or	Full Draw-	258	Gt	Steel Open Med L	358	Ba	Finger Hard	458	St	Solo Combi3 St	558	Br	Brass Sect1 R- Of
59	Ep	EP2 Sw	159	Or	Swish	259	Gt	Steel Open Med R	359	Ba	Finger Harmonics	459	St	Solo Combi3 L	559	Br	Brass Sect1 R- Of
60	Ep	EP2 Soft1	160	Or	Swish-	260	Gt	Steel Open Hard St	360	Ba	Finger Med+	460	St	Solo Combi3 R	560	Br	Brass Sect Fall
61	Ep	EP2 Soft1+	161	Or	Bow	261	Gt	Steel Open Hard L	361	Ba	Finger Hard+	461	St	Solo Combi3 St Of	561	Br	Brass Sect2 Soft St
62	Ep	EP2 Soft1-	162	Or	Bow Chorus Vibrato	262	Gt	Steel Open Hard R	362	Ba	Finger Med-	462	St	Solo Combi3 L Of	562	Br	Brass Sect2 Soft St+
63	Ep	EP2 Soft2	163	Or	Gospel	263	Gt	Steel Open Sw St	363	Ba	Finger Hard-	463	St	Solo Combi3 R Of	563	Br	Brass Sect2 Soft St-
64	Ep	EP2 Soft2+	164	Or	Soul	264	Gt	Steel Open Sw L	364	Ba	Finger Dead	464	St	Solo Spiccato Combi	564	Br	Brass Sect2 Soft L
65	Ep	EP2 Soft2-	165	Or	1st Four Draw	265	Gt	Steel Open Sw R	365	Ba	P-Bass Rndwound Med	465	St	Solo Spiccato Combi+	565	Br	Brass Sect2 Soft L-
66	Ep	EP2 Hard1	166	Or	Draw 16'	266	Gt	Steel Open Sw Kb St	366	Ba	P-Bass Rndwound Hard	466	St	Solo Spiccato Combi-	566	Br	Brass Sect2 Soft L-
67	Ep	EP2 Hard1+	167	Or	Draw 5 1/3	267	Gt	Steel Open Sw Kb L	367	Ba	P-Bass Rndwound Med+	467	St	Pizzicato1 St	567	Br	Brass Sect2 Soft R
68	Ep	EP2 Hard1-	168	Or	Draw 8'	268	Gt	Steel Open Sw Kb R	368	Ba	P-Bass Rndwound Hrd+	468	St	Pizzicato1 Mono	568	Br	Brass Sect2 Soft R+
69	Ep	EP2 Hard2	169	Or	Draw 4'	269	Gt	Steel Hammer On St	369	Ba	P-Bass Rndwound Med-	469	St	Pizzicato 2	569	Br	Brass Sect2 Soft R-
70	Ep	EP2 Hard2+	170	Or	Draw 2 2/3	270	Gt	Steel Hammer On L	370	Ba	P-Bass Rndwound Hrd-	470	St	Pop Pizzicato	570	Br	Brass Sect2 SoftStOf
71	Ep	EP2 Hard2-	171	Or	Draw 2'	271	Gt	Steel Hammer On R	371	Ba	P-Bass Flatwound	471	St	Large Pizzicato St	571	Br	Brass Sect2 Soft L Of
72	Ep	EP3 Sw	172	Or	Draw 1 3/5	272	Gt	Steel Slide St	372	Ba	P-Bass Flatwound+	472	St	Large Pizzicato L	572	Br	Brass Sect2 Soft ROf
73	Ep	EP3 Soft1	173	Or	Draw 1 1/3	273	Gt	Steel Slide L	373	Ba	P-Bass Flatwound-	473	St	Large Pizzicato R	573	Br	Brass Sect2 Soft St+
74	Ep	EP3 Soft1+	174	Or	Draw 1'	274	Gt	Steel Slide R	374	Ba	Thumb/Pull Hard	474	St	Large Pizzicato St+	574	Br	Brass Sect2 Med St+
75	Ep	EP3 Soft1-	175	Or	Draw 16' Of	275	Gt	Steel Harmonics St	375	Ba	Thumb Hard	475	St	Large Pizzicato L+	575	Br	Brass Sect2 Med St-
76	Ep	EP3 Soft2	176	Or	Draw 5 1/3 Of	276	Gt	Steel Harmonics L	376	Ba	Thumb Harmonics	476	St	Large Pizzicato R Of	576	Br	Brass Sect2 Med L Of
77	Ep	EP3 Soft2+	177	Or	Draw 8' Of	277	Gt	Steel Harmonics R	377	Ba	Thumb Soft	477	St	Large Pizzicato St-	577	Br	Brass Sect2 Med L+
78	Ep	EP3 Soft2-	178	Or	Draw 4' Of	278	Gt	Steel Mute St	378	Ba	Thumb Dead	478	St	Large Pizzicato L-	578	Br	Brass Sect2 Med L-
79	Ep	EP3 Hard1	179	Or	Draw 2 2/3 Of	279	Gt	Steel Mute L	379	Ba	Pull Dead	479	St	Large Pizzicato R-	579	Br	Brass Sect2 Med R
80	Ep	EP3 Hard1+	180	Or	Draw 2' Of	280	Gt	Steel Mute R	380	Ba	Fretless	480	St	Ensemble Mix	580	Br	Brass Sect2 Med R+
81	Ep	EP3 Hard1-	181	Or	Draw 1 3/5 Of	281	Gt	Steel Dead Notes St	381	Ba	Fretless Harmonics	481	St	Ensemble Mix R	581	Br	Brass Sect2 Med R-
82	Ep	EP3 Hard2	182	Or	Draw 1 1/3 Of	282	Gt	Steel Dead Notes L	382	Ba	Fretless+	482	St	Ensemble Mix L	582	Br	Brass Sect2 Med StOf
83	Ep	EP3 Hard2+	183	Or	Draw 1' Of	283	Gt	Steel Dead Notes R	383	Ba	Fretless-	483	St	Ensemble Mix R	583	Br	Brass Sect2 Med L Of
84	Ep	EP3 Hard2-	184	Or	Draw 1+3	284	Gt	Steel FX St	384	Ba	Fretless Dead	484	St	Ensemble Mix St Of	584	Br	Brass Sect2 Med R Of
85	Ep	EP Key Off	185	Or	Draw 1+3+	285	Gt	Steel FX L	385	Ba	Electric Bass FX	485	St	Ensemble Mix L Of	585	Br	Brass Sect2 Hard

No	Category	Name	No	Category	Name	No	Category	Name	No	Category	Name	No	Category	Name	No	Category	Name
601	Br	Trumpet 2	701	Rd	Clarinet Hard L+	801	Pi	Flute2 Hard L-	901	Pc	Mondira	1001	Wv	Analog Bass4	1101	Wv	Med Detuned Pad L
602	Br	Trumpet 2+	702	Rd	Clarinet Hard L	802	Pi	Flute2 Hard R	902	Pc	Tibetan Bell	1002	Wv	Analog Bass4 Of	1102	Wv	Med Detuned Pad R
603	Br	Trumpet 2-	703	Rd	Clarinet Hard R	803	Pi	Flute2 Hard R+	903	Pc	Tibetan Bowl	1003	Wv	Analog Bass5	1103	Wv	StrongDetuned Pad St
604	Br	Trumpet 2 Of	704	Rd	Clarinet Hard R+	804	Pi	Flute2 Hard R-	904	Pc	Ghungghuru	1004	Wv	Analog Bass5 Of	1104	Wv	StrongDetuned Pad L
605	Br	Trumpet Mute	705	Rd	Clarinet Hard R-	805	Pi	Flute2 Hard St Of	905	Vo	Hah Choir St	1005	Wv	Analog Bass6	1105	Wv	StrongDetuned Pad R
606	Br	Trumpet Mute Of	706	Rd	Clarinet Hard St Of	806	Pi	Flute2 Hard L Of	906	Vo	Hah Choir L	1006	Wv	Analog Bass6 Of	1106	Wv	Med Detuned 3osc
607	Br	Trombone1	707	Rd	Clarinet Hard L Of	807	Pi	Flute2 Hard R Of	907	Vo	Hah Choir R	1007	Wv	UniBass	1107	Wv	XP Brass
608	Br	Trombone1-	708	Rd	Clarinet Hard R Of	808	Pi	Piccolo	908	Vo	Ooh Choir St	1008	Wv	UniBass Of	1108	Wv	XP Brass Lp
609	Br	Trombone1 Of	709	Rd	Oboe1	809	Pi	Piccolo Of	909	Vo	Ooh Choir L	1009	Wv	T8 Kick Bass	1109	Wv	Heterodyning
610	Br	Trombone1- Of	710	Rd	Oboe1 Of	810	Pi	Pan Flute	910	Vo	Ooh Choir R	1010	Wv	T8 Kick Bass Of	1110	Me	Birch St
611	Br	Trombone2	711	Rd	Oboe2 Med St	811	Pi	Pan Flute-	911	Vo	Ooh St	1011	Wv	FM Bass1	1111	Me	Birch L
612	Br	Trombone2 Of	712	Rd	Oboe2 Med St+	812	Pi	Irish Pipe	912	Vo	Ooh L	1012	Wv	FM Bass2	1112	Me	Birch R
613	Br	Soft Trombone	713	Rd	Oboe2 Med St-	813	Pi	Irish Pipe Of	913	Vo	Ooh R	1013	Wv	FM Bass3	1113	Me	Willow St
614	Br	Soft Trombone Of	714	Rd	Oboe2 Med L	814	Pi	Shakuhachi	914	Vo	Ooh St Of	1014	Wv	FM Bass4	1114	Me	Willow L
615	Br	Soft Flugelhorn	715	Rd	Oboe2 Med L+	815	Pi	Shakuhachi Of	915	Vo	Ooh L Of	1015	Wv	FM Bass5	1115	Me	Willow R
616	Br	Soft Flugelhorn-	716	Rd	Oboe2 Med L-	816	Pi	Recorder	916	Vo	Ooh R Of	1016	Wv	FM Bass6	1116	Me	Anemone St
617	Br	Soft Flugelhorn Of	717	Rd	Oboe2 Med R	817	Pi	Recorder Of	917	Vo	Cho Breath L	1017	Wv	Mini Blip1	1117	Me	Anemone L
618	Br	Soft Flugelhorn- Of	718	Rd	Oboe2 Med R+	818	Pi	Bottle	918	Vo	Cho Breath R	1018	Wv	Mini Blip2	1118	Me	Anemone R
619	Br	Flugelhorn	719	Rd	Oboe2 Med R-	819	Pi	Ocarina	919	Vo	SynVox	1019	Wv	Mini Blip3	1119	Me	Magnitude St
620	Br	Flugelhorn Of	720	Rd	Oboe2 Med St Of	820	Pi	Ocarina Of	920	Vo	VoxNoiz	1020	Wv	Mini Blip4	1120	Me	Magnitude L
621	Br	French Horn St	721	Rd	Oboe2 Med L Of	821	Pi	Human Whistle	921	Vo	Itpia	1021	Wv	Mini Blip5	1121	Me	Magnitude R
622	Br	French Horn L	722	Rd	Oboe2 Med R Of	822	Pi	Breath One Shot	922	Wv	PWM Strings St	1022	Wv	Mini Blip6	1122	Me	SabreTone
623	Br	French Horn R	723	Rd	Oboe2 Hard St	823	Pi	Didgeridoo 1	923	Wv	PWM Strings Mn	1023	Wv	FM Square	1123	Me	String Pad St
624	Br	French Horn St+	724	Rd	Oboe2 Hard St+	824	Pi	Didgeridoo 2	924	Wv	Long Saw	1024	Wv	FM Shaper	1124	Me	String Pad L
625	Br	French Horn L+	725	Rd	Oboe2 Hard St-	825	Pi	Didgeridoo 3	925	Wv	Fat Saw St	1025	Wv	FM Metal1	1125	Me	String Pad R
626	Br	French Horn R+	726	Rd	Oboe2 Hard L	826	Pi	Didgeridoo Combi1	926	Wv	Fat Saw Mn	1026	Wv	FM Metal2	1126	Me	VocalRes
627	Br	French Horn St-	727	Rd	Oboe2 Hard L+	827	Pi	Didgeridoo Combi2	927	Wv	Fat Saw Mn-	1027	Wv	FM Organ1	1127	Me	Orchestra Hit1 St
628	Br	French Horn L-	728	Rd	Oboe2 Hard L-	828	Pi	Sho	928	Wv	OB Mod Saw	1028	Wv	FM Organ2	1128	Me	Orchestra Hit1 L
629	Br	French Horn R-	729	Rd	Oboe2 Hard R	829	Pi	Shanai	929	Wv	VP Strings St	1029	Wv	FM Organ3	1129	Me	Orchestra Hit1 R
630	Br	French Horn St Of	730	Rd	Oboe2 Hard R+	830	Pi	Shanai Of	930	Wv	VP Strings L	1030	Wv	FM Organ4	1130	Me	Orchestra Hit2 St
631	Br	French Horn L Of	731	Rd	Oboe2 Hard R-	831	Pi	Ney	931	Wv	VP Strings R	1031	Wv	FM Funk	1131	Me	Orchestra Hit2 L
632	Br	French Horn R Of	732	Rd	Oboe2 Hard St Of	832	Pi	Ney Of	932	Wv	OB Strings	1032	Wv	FM Guitar	1132	Me	Orchestra Hit2 R
633	Br	French Horn St+ Of	733	Rd	Oboe2 Hard L Of	833	Pi	Kaval	933	Wv	Syzzle Strings	1033	Wv	FS Buzz	1133	Me	Orchestra Hit3
634	Br	French Horn L+ Of	734	Rd	Oboe2 Hard R Of	834	Pi	Kaval Of	934	Wv	Padd	1034	Wv	Wet Pluck	1134	Me	Vox Bell
635	Br	French Horn R+ Of	735	Rd	English Horn	835	St	Keman	935	Wv	Dark Light	1035	Wv	Lately-S	1135	Me	Mellow
636	Br	French Horn St- Of	736	Rd	English Horn Of	836	St	Keman Of	936	Wv	OB Brass	1036	Wv	Lately-L	1136	Me	Fx Chime
637	Br	French Horn L- Of	737	Rd	Bassoon Med St	837	Gt	Sitar	937	Wv	Trance St	1037	Wv	P10-1	1137	Me	BelAir
638	Br	French Horn R- Of	738	Rd	Bassoon Med St+	838	Gt	Sitar Waves1	938	Wv	Trance Mn	1038	Wv	P10-2	1138	Me	BigSyn
639	Br	French Horn Solo	739	Rd	Bassoon Med St-	839	Gt	Sitar Waves2	939	Wv	Ring Mod	1039	Wv	P10-3	1139	Me	Trance Choir
640	Br	French Horn Solo+	740	Rd	Bassoon Med L	840	Gt	Sitar Waves3	940	Wv	Sync Lead1	1040	Wv	P25-1	1140	Me	StabOrgan1
641	Br	French Horn Solo-	741	Rd	Bassoon Med L+	841	Gt	Sitar Waves4	941	Wv	Sync Lead2	1041	Wv	P25-2	1141	Me	Eery
642	Br	French Horn Solo Of	742	Rd	Bassoon Med L-	842	Gt	Sitar Waves5	942	Wv	Sync Lead3	1042	Wv	P50-1	1142	Me	Electer
643	Br	French Horn Solo+ Of	743	Rd	Bassoon Med R	843	Gt	Sitar Waves6	943	Wv	Sync Lead4	1043	Wv	P50-2	1143	Me	HH Hit
644	Br	French Horn Solo- Of	744	Rd	Bassoon Med R+	844	Gt	Tambura	944	Wv	Sync Lead5	1044	Wv	Tri Wave	1144	Me	VoxAlk
645	Br	Tuba	745	Rd	Bassoon Med R-	845	Gt	Tambura Waves1	945	Wv	Sync LFO	1045	Wv	Digi 01	1145	Me	MultiPiano
646	Br	Tuba Lp	746	Rd	Bassoon Med St Of	846	Gt	Tambura Waves2	946	Wv	PWM Tak	1046	Wv	Digi 02	1146	Me	Bel Choir
647	Rd	Soprano Sax1	747	Rd	Bassoon Med L Of	847	Gt	Tambura Waves3	947	Wv	PWM Slow	1047	Wv	Digi 03	1147	Me	Bel Choir Lp
648	Rd	Soprano Sax1 Of	748	Rd	Bassoon Med R Of	848	Gt	Santur	948	Wv	CS80 Brass	1048	Wv	Digi 04	1148	Me	Dirty Perc
649	Rd	Soprano Sax2	749	Rd	Bassoon Hard St	849	Gt	Ud	949	Wv	P5 SawDown 0 dg	1049	Wv	Digi 05	1149	Me	Hi-Lo
650	Rd	Soprano Sax2 Of	750	Rd	Bassoon Hard St+	850	Gt	Kanun	950	Wv	P5 SawDown 180 dg	1050	Wv	Digi 06	1150	Me	AirHose St
651	Rd	Alto Sax1	751	Rd	Bassoon Hard St-	851	Gt	Baglama	951	Wv	P5 SawDown PhaseRndm	1051	Wv	Digi 07	1151	Me	AirHose L
652	Rd	Alto Sax1 Of	752	Rd	Bassoon Hard L	852	Gt	Bouzouki	952	Wv	P5 SawUp 0 dg	1052	Wv	Digi 08	1152	Me	AirHose R
653	Rd	Alto Sax2	753	Rd	Bassoon Hard L+	853	Gt	Shamisen	953	Wv	P5 SawUp 90 dg	1053	Wv	Digi 09	1153	Me	Bubble
654	Rd	Alto Sax2 Of	754	Rd	Bassoon Hard L-	854	Gt	Koto	954	Wv	P5 SawUp 180 dg	1054	Wv	Digi 10	1154	Me	Swarm
655	Rd	Alto Sax Vb	755	Rd	Bassoon Hard R	855	Cp	Kalimba	955	Wv	P5 SawUp 270 dg	1055	Wv	Digi 11	1155	Me	Lektronika
656	Rd	Alto Sax Vb Of	756	Rd	Bassoon Hard R+	856	Cp	Gamelan1	956	Wv	OB Saw	1056	Wv	Digi 12	1156	Me	Space Scream
657	Rd	Tenor Sax1	757	Rd	Bassoon Hard R-	857	Cp	Gamelan2	957	Wv	Saw	1057	Wv	Bell1 Wave	1157	Me	Radio Noise
658	Rd	Tenor Sax1 Of	758	Rd	Bassoon Hard St Of	858	Cp	Steel Drum	958	Wv	3o3 Saw	1058	Wv	Bell2 Wave	1158	Me	Ooh Feedback
659	Rd	Tenor Sax2 Hard	759	Rd	Bassoon Hard L Of	859	Pc	Log Drum1	959	Wv	3o3 Saw2	1059	Wv	DigiVox1	1159	Me	Fairwave
660	Rd	Tenor Sax2 Hard+	760	Rd	Bassoon Hard R Of	860	Pc	Log Drum2	960	Wv	3o3 Square	1060	Wv	DigiVox2	1160	Me	Hoo
661	Rd	Tenor Sax2 Hard-	761	Rd	Bagpipe1	861	Pc	Wataiko	961	Wv	1o1 Saw	1061	Wv	DigiVox3	1161	Me	Mini Bell
662	Rd	Tenor Sax2 Hard Of	762	Rd	Bagpipe2	862	Pc	Djembe Edge	962	Wv	1o1 Sub	1062	Wv	DigiVox4	1162	Me	Loop145
663	Rd	Tenor Sax2 Med	763	Rd	Sax Breath	863	Pc	Djembe Mute	963	Wv	Saw Square	1063	Wv	DigiVox5	1163	Me	X-Fade
664	Rd	Tenor Sax2 Med+	764	Rd	Harmonica	864	Pc	Djembe Open	964	Wv	Square Saw	1064	Wv	Vox G2	1164	Me	Resonance X-Fade
665	Rd	Tenor Sax2 Med-	765	Rd	Chromatic Harmonica	865	Pc	Djembe Combi	965	Wv	Mini Bass1	1065	Wv	Vox E3	1165	Me	Quiet
666	Rd	Tenor Sax2 Med Of	766	Rd	Blues Harmonica	866	Pc	Tabla Bya	966	Wv	Mini Bass1 Of	1066	Wv	DigiOsc1	1166	Me	LFO Seq
667	Rd	Tenor Sax2 Growl	767	Pi	Flute Non-Vib	867	Pc	Tabla Nah	967	Wv	Mini Bass2	1067	Wv	DigiOsc2	1167	Me	Hop FX1
668	Rd	Tenor Sax2 Growl+	768	Pi	Flute Non-Vib Of	868	Pc	Tabla Mute	968	Wv	Mini Bass2 Of	1068	Wv	DigiOsc3	1168	Me	Hop FX2
669	Rd	Tenor Sax2 Growl-	769	Pi	Flute1	869	Pc	Tabla Combi	969	Wv	Mini Bass3a	1069	Wv	DigiOsc4	1169	Me	Sonar1
670	Rd	Tenor Sax2 Growl Of	770	Pi	Flute1 Of	870	Pc	Small Tabla Dom	970	Wv	Mini Bass3b	1070	Wv	DigiOsc5	1170	Me	Sonar2
671	Rd	Baritone Sax	771	Pi	Flute1 Attack	871	Pc	Small Tabla Snap	971	Wv	Mini Bass3c	1071	Wv	DigiOsc6	1171	Me	Hit Orchestra1
672	Rd	Baritone Sax Of	772	Pi	Flute2 Soft St	872	Pc	Small Tabla Sak	972	Wv	Q Synbass	1072	Wv	DigiOsc7	1172	Me	Hit Brass
673	Rd	Clarinet Soft St	773	Pi	Flute2 Soft St+	873	Pc	Small Tabla Tak	973	Wv	Q Synbass Of	1073	Wv	EP Wave 1	1173	Me	Stab Orchestra
674	Rd	Clarinet Soft St+	774	Pi	Flute2 Soft St-	874	Pc	Big Tabla Dom	974	Wv	Punch	1074	Wv	EP Wave 2	1174	Me	Stab Giant
675	Rd	Clarinet Soft St-	775	Pi	Flute2 Soft L	875	Pc	Big Tabla Tak	975	Wv	Punch Of	1075	Wv	EP Wave 3	1175	Me	Stab Hard
676	Rd	Clarinet Soft L	776	Pi	Flute2 Soft L+	876	Pc	Big Tabla Sak	976	Wv	Synth Bass1	1076	Wv	EP Wave 4	1176	Me	Stab Organ2
677	Rd	Clarinet Soft L+	777	Pi	Flute2 Soft L-	877	Pc	Tabla Dom	977	Wv	Synth Bass2	1077	Wv	EP Wave 5	1177	Me	Stab Aah
678	Rd	Clarinet Soft R	778	Pi	Flute2 Soft R	878	Pc	Tabla Tak1	978	Wv	Blip Bass	1078	Wv	EP Wave 6	1178	Me	Hit UhH
679	Rd	Clarinet Soft R+	779	Pi	Flute2 Soft R+	879	Pc	Tabla Tak2	979	Wv	Blip Bass Of	1079	Wv	Organ Wave1	1179	Me	Hit Orchestra2
680	Rd	Clarinet Soft R-	780	Pi	Flute2 Soft R-	880	Pc	Tabla Tik1	980	Wv	Klick Bass	1080	Wv	Organ Wave2	1180	Me	Vox Drum
681	Rd	Clarinet Soft R Of	781	Pi	Flute2 Soft St Of	881	Pc	Tabla Tik2	981	Wv	Klick Bass Of	1081	Wv	Organ Wave3	1181	Me	Raspberry
682	Rd	Clarinet Soft St Of	782	Pi	Flute2 Soft L Of	882	Pc	Tabla Tik3	982	Wv	Puls Bass	1082	Wv	DigiBell1	1182	Me	Digi Breath
683	Rd	Clarinet Soft L Of	783	Pi	Flute2 Soft R Of	883	Pc	Tabla Sak1	983	Wv	Puls Bass Of	1083	Wv	DigiBell2	1183	Me	Engine Room St
684	Rd	Clarinet Soft R Of	784	Pi	Flute2 Med St	884	Pc	Tabla Tremolo	984	Wv	Short Uni	1084	Wv	DigiBell3	1184	Me	Engine Room L
685	Rd	Clarinet Med St	785	Pi	Flute2 Med St+	885	Pc</										

No	Category	Name	No	Category	Name	No	Category	Name	No	Category	Name	No	Category	Name	No	Category	Name
1201	Me	Neo Seq Em-1	1301	Se	Door Squeak	1401	Pc	Cabasa2	1501	Dr	Bd Snap 1	1601	Dr	Bd PowerB 2St	1701	Dr	Sd Blk R4
1202	Me	Neo Seq Em-2	1302	Se	Heart Beat	1402	Pc	Caxix1-2	1502	Dr	Bd Snap 2	1602	Dr	Bd PowerB 2R	1702	Dr	Sd Soul St1-4
1203	Me	Neo Seq Em-3	1303	Se	Helicopter	1403	Pc	Caxix1	1503	Dr	Bd Snap L1-2	1603	Dr	Bd PowerB 2L	1703	Dr	Sd Soul St1-3
1204	Me	Neo Seq Em-4	1304	Se	Seashore	1404	Pc	Caxix2	1504	Dr	Bd Snap R1-2	1604	Dr	Bd Gran Casa Open St	1704	Dr	Sd Soul St2-4
1205	Me	Neo Seq Em-5	1305	Se	Telephone	1405	Pc	Shaker 1/3	1505	Dr	Bd Snap L1	1605	Dr	Bd Gran Casa Open L	1705	Dr	Sd Soul St1-2
1206	Me	Neo Seq Em-6	1306	Se	TelRing	1406	Pc	Shaker 1	1506	Dr	Bd Snap L2	1606	Dr	Bd Gran Casa Open R	1706	Dr	Sd Soul St2-3
1207	Me	Neo Seq Em-7	1307	Se	Bird	1407	Pc	Shaker 2	1507	Dr	Bd Snap R1	1607	Dr	Bd Gran Casa Mute St	1707	Dr	Sd Soul St3-4
1208	Me	Neo Seq Em-8	1308	Se	Stream	1408	Pc	Shaker 3	1508	Dr	Bd Snap R2	1608	Dr	Bd Gran Casa Mute L	1708	Dr	Sd Soul L1-4
1209	Me	Whisper Seq Bb	1309	Se	Gunshot	1409	Pc	Shaker Hip1	1509	Dr	Bd Tight 1-2	1609	Dr	Bd Gran Casa Mute R	1709	Dr	Sd Soul R1-4
1210	Me	Whisper Seq Bb Of	1310	Se	Applause	1410	Pc	Shaker Hip2	1510	Dr	Bd Tight 1	1610	Dr	Bd Gate	1710	Dr	Sd Soul St1
1211	Me	Woody Seq St	1311	Se	RainLoop	1411	Pc	Shaker Hip3	1511	Dr	Bd Tight 2	1611	Dr	Bd FX Gate	1711	Dr	Sd Soul St2
1212	Me	Woody Seq L	1312	Se	Scratch H	1412	Pc	Shaker Hip4	1512	Dr	Bd Tight L1-2	1612	Dr	Bd T9-1	1712	Dr	Sd Soul St3
1213	Me	Woody Seq R	1313	Se	Scratch L	1413	Pc	Shakere Down	1513	Dr	Bd Tight R1-2	1613	Dr	Bd T9-2	1713	Dr	Sd Soul St4
1214	Me	Motion Beam	1314	Se	Scratch Down	1414	Pc	Shakere Up	1514	Dr	Bd Tight L1	1614	Dr	Bd T9-3	1714	Dr	Sd Soul L1
1215	Me	Warning Mod	1315	Se	Scratch Hi F	1415	Pc	Shakere Sap	1515	Dr	Bd Tight L2	1615	Dr	Bd T9-4	1715	Dr	Sd Soul L2
1216	Me	Neo Seq2 Em All	1316	Se	Scratch Hi R	1416	Pc	Tumbo 1	1516	Dr	Bd Tight R1	1616	Dr	Bd T9 Hd1	1716	Dr	Sd Soul L3
1217	Me	Neo Seq2 Em-1	1317	Se	Scratch Lo F	1417	Pc	Tumbo 2	1517	Dr	Bd Tight R2	1617	Dr	Bd T9 Hd2	1717	Dr	Sd Soul L4
1218	Me	Neo Seq2 Em-2	1318	Se	Scratch Lo R	1418	Pc	Tumbo 3	1518	Dr	Bd Ambience 1-2	1618	Dr	Bd T9 Hd3	1718	Dr	Sd Soul R1
1219	Me	Neo Seq2 Em-3	1319	Se	Scratch Bd F	1419	Pc	Tambourine1 Sw	1519	Dr	Bd Ambience 1	1619	Dr	Bd T8-1	1719	Dr	Sd Soul R2
1220	Me	Neo Seq2 Em-4	1320	Se	Scratch Bd R	1420	Pc	Tambourine1 Hit	1520	Dr	Bd Ambience 2	1620	Dr	Bd T8-2	1720	Dr	Sd Soul R3
1221	Me	Neo Seq2 Em-5	1321	Se	Scratch Sd F	1421	Pc	Tambourine1 Shake	1521	Dr	Bd Ambience L1-2	1621	Dr	Bd T8-3	1721	Dr	Sd Soul R4
1222	Me	Neo Seq2 Em-6	1322	Se	Scratch Sd R	1422	Pc	Pandeiro Open	1522	Dr	Bd Ambience R1-2	1622	Dr	Bd AnSm	1722	Dr	Sd Strong St1-4
1223	Me	Neo Seq2 Em-7	1323	Se	Scratch Vo F	1423	Pc	Pandeiro Thump	1523	Dr	Bd Ambience L1	1623	Dr	Bd AnCR	1723	Dr	Sd Strong St1-3
1224	Me	Neo Seq2 Em-8	1324	Se	Scratch Vo R	1424	Pc	Pandeiro Tip	1524	Dr	Bd Ambience L2	1624	Dr	Bd Human1	1724	Dr	Sd Strong St2-4
1225	Me	Portamento Lead Seq	1325	Se	Scratch Stop	1425	Pc	Pandeiro Heel	1525	Dr	Bd Ambience R1	1625	Dr	Bd Human2	1725	Dr	Sd Strong St1-2
1226	Me	Aero Seq All	1326	Se	Scratch Spin	1426	Pc	Tmbourim Open	1526	Dr	Bd Ambience R2	1626	Dr	Bd Blip	1726	Dr	Sd Strong St2-3
1227	Me	Aero Seq-1	1327	Se	Scratch Hip	1427	Pc	Tmbourim Finger	1527	Dr	Bd Normal St1-2	1627	Dr	Bd BlpHd	1727	Dr	Sd Strong St3-4
1228	Me	Aero Seq-2	1328	Se	Scratch Hip2	1428	Pc	Tmbourim Mute	1528	Dr	Bd Normal 1St	1628	Dr	Bd Jungle1	1728	Dr	Sd Strong St1
1229	Me	Aero Seq-3	1329	Se	Scratch Attack	1429	Pc	Agogo Hi	1529	Dr	Bd Normal 2St	1629	Dr	Bd Jungle2	1729	Dr	Sd Strong St2
1230	Me	Aero Seq-4	1330	Se	Scratch R&B	1430	Pc	Agogo Lo	1530	Dr	Bd Normal L1-2	1630	Dr	Bd Jungle3	1730	Dr	Sd Strong St3
1231	Me	Aero Seq-5	1331	Se	Scratch Combi	1431	Pc	Agogo Lo Tap	1531	Dr	Bd Normal R1-2	1631	Dr	Bd D&B1	1731	Dr	Sd Strong St4
1232	Me	Aero Seq-6	1332	Se	Scratch Combi2	1432	Pc	Guiro Long	1532	Dr	Bd Normal 1R	1632	Dr	Bd D&B2	1732	Dr	Sd Strong L1-4
1233	Me	Aero Seq-7	1333	Se	Scratch Combi3	1433	Pc	Guiro Short	1533	Dr	Bd Normal 1R	1633	Dr	Bd R&B1	1733	Dr	Sd Strong R1-4
1234	Me	Aero Seq-8	1334	Se	Scratch Combi4	1434	Pc	Guiro Swp	1534	Dr	Bd Normal 2L	1634	Dr	Bd R&B2	1734	Dr	Sd Strong L1
1235	Me	Aero Seq-9	1335	Pc	Conga Hi Tip	1435	Pc	MetalGuiro Short1-2	1535	Dr	Bd Normal 2R	1635	Dr	Bd Hip Deep	1735	Dr	Sd Strong L2
1236	Me	Aero Seq-10	1336	Pc	Conga Hi Heel	1436	Pc	MetalGuiro Short1	1536	Dr	Bd Funk St1-2	1636	Dr	Bd Break Deep	1736	Dr	Sd Strong L3
1237	Me	Aero Seq-11	1337	Pc	Conga Hi Open 1-2	1437	Pc	MetalGuiro Short2	1537	Dr	Bd Funk 1St	1637	Dr	Bd Break1	1737	Dr	Sd Strong L4
1238	Me	Aero Seq-12	1338	Pc	Conga Hi Open 1	1438	Pc	MetalGuiro Long	1538	Dr	Bd Funk 2St	1638	Dr	Bd Break2	1738	Dr	Sd Strong R1
1239	Me	Aero Seq-13	1339	Pc	Conga Hi Open 2	1439	Pc	Surdo Open	1539	Dr	Bd Funk L1-2	1639	Dr	Bd Break Heavy	1739	Dr	Sd Strong R2
1240	Me	Aero Seq-14	1340	Pc	Conga Hi Mute	1440	Pc	Surdo Mute	1540	Dr	Bd Funk R1-2	1640	Dr	Bd Break Hard	1740	Dr	Sd Strong R3
1241	Me	Aero Seq-15	1341	Pc	Conga Hi Slip Open	1441	Pc	Cajon Kick	1541	Dr	Bd Funk 1 L	1641	Dr	Bd Distortion1	1741	Dr	Sd Strong R4
1242	Me	Aero Seq-16	1342	Pc	Conga Hi Slap	1442	Pc	Cajon Slap	1542	Dr	Bd Funk 1 R	1642	Dr	Bd Distortion2	1742	Dr	Sd Rng St1-4
1243	Me	FM Tubular Bass	1343	Pc	Conga Hi SlapMute1-2	1443	Pc	Cajon Tip 1-2	1543	Dr	Bd Funk 2 L	1643	Dr	Bd Distortion3	1743	Dr	Sd Rng St1-3
1244	Se	Fx Female Voice St	1344	Pc	Conga Hi SlapMute 1	1444	Pc	Cajon Tip 1	1544	Dr	Bd Funk 2 R	1644	Dr	Bd Distortion4	1744	Dr	Sd Rng St2-4
1245	Se	Fx Female Voice L	1345	Pc	Conga Hi SlapMute 2	1445	Pc	Cajon Tip 2	1545	Dr	Bd High St	1645	Dr	Bd Distortion5	1745	Dr	Sd Rng St1-2
1246	Se	Fx Female Voice R	1346	Pc	Conga Lo Tip	1446	Pc	Stick 1	1546	Dr	Bd High L	1646	Dr	Bd Distortion RM	1746	Dr	Sd Rng St2-3
1247	Se	Grain1	1347	Pc	Conga Lo Heel	1447	Pc	Stick 2	1547	Dr	Bd High R	1647	Dr	Bd +HH	1747	Dr	Sd Rng St3-4
1248	Se	Grain2 St	1348	Pc	Conga Lo Open 1-2	1448	Pc	Castanet	1548	Dr	Bd Low St	1648	Dr	Bd FxHammer	1748	Dr	Sd Rng St1
1249	Se	Grain2 L	1349	Pc	Conga Lo Open 1	1449	Pc	Clave	1549	Dr	Bd Low L	1649	Dr	Bd ZapHard	1749	Dr	Sd Rng St2
1250	Se	Grain2 R	1350	Pc	Conga Lo Open 2	1450	Pc	Wood Block	1550	Dr	Bd Low R	1650	Dr	Bd ZapMid	1750	Dr	Sd Rng St3
1251	Se	Grain3 St	1351	Pc	Conga Lo Mute	1451	Pc	Vibrastap	1551	Dr	Bd H Son St	1651	Dr	Bd Sustain	1751	Dr	Sd Rng St4
1252	Se	Grain3 L	1352	Pc	Conga Lo SlapOpen	1452	Pc	Whistle	1552	Dr	Bd H Son L	1652	Dr	Bd TekPower	1752	Dr	Sd Rng L1-4
1253	Se	Grain3 R	1353	Pc	Quinto L Open	1453	Pc	Triangle Sw	1553	Dr	Bd H Son R	1653	Dr	Bd Hard Long	1753	Dr	Sd Rng R1-4
1254	Se	Moving Harp St	1354	Pc	Quinto L Slap	1454	Pc	Triangle Open	1554	Dr	Bd L Son St	1654	Dr	Bd Analog Tight	1754	Dr	Sd Rng L1
1255	Se	Moving Harp L	1355	Pc	Quinto 2 Open	1455	Pc	Triangle Mute	1555	Dr	Bd L Son L	1655	Dr	Bd AnaHard	1755	Dr	Sd Rng L2
1256	Se	Moving Harp R	1356	Pc	Quinto 2 Heel	1456	Pc	HandClap St	1556	Dr	Bd L Son R	1656	Dr	Bd Lo-Fi	1756	Dr	Sd Rng L3
1257	Se	Metal Mod	1357	Pc	Tumba Open	1457	Pc	HandClap L	1557	Dr	Bd Funk Son St	1657	Dr	Bd ThickSkin	1757	Dr	Sd Rng L4
1258	Se	Digital Wind	1358	Pc	Tumba Slap	1458	Pc	HandClap R	1558	Dr	Bd Funk Son L	1658	Dr	Bd Slimy	1758	Dr	Sd Rng St1
1259	Se	Digi Voice Mod	1359	Pc	Tumba Tip	1459	Pc	Handbell L	1559	Dr	Bd Funk Son R	1659	Dr	Bd Elec1	1759	Dr	Sd Rng R2
1260	Se	Ethnic Rhythm Rv All	1360	Pc	Tumba Heel	1460	Pc	Handbell H	1560	Dr	Bd Rock1 St	1660	Dr	Bd Elec2	1760	Dr	Sd Rng R3
1261	Se	Ethnic Rhythm Rv-1	1361	Pc	Cuica Lo	1461	Pc	Cowbell1	1561	Dr	Bd Rock1 L	1661	Dr	Bd Elec3	1761	Dr	Sd Rng R4
1262	Se	Ethnic Rhythm Rv-2	1362	Pc	Cuica Hi	1462	Pc	Cowbell2	1562	Dr	Bd Rock1 R	1662	Dr	Bd Elec4	1762	Dr	Sd Normal St1-4
1263	Se	Ethnic Rhythm Rv-3	1363	Pc	Bongo Hi 1Finger 1-2	1463	Pc	Mambo B1	1563	Dr	Bd Rock2 St	1663	Dr	Bd ElecComp1	1763	Dr	Sd Normal St1-3
1264	Se	Ethnic Rhythm Rv-4	1364	Pc	Bongo Hi 1Finger 1	1464	Pc	Mambo B2	1564	Dr	Bd Rock2 L	1664	Dr	Bd ElecComp2	1764	Dr	Sd Normal St2-4
1265	Se	Ethnic Rhythm Rv-5	1365	Pc	Bongo Hi 1Finger 2	1465	Pc	Mambo Body	1565	Dr	Bd Rock2 R	1665	Dr	Bd ElecComp3	1765	Dr	Sd Normal St1-2
1266	Se	Ethnic Rhythm Rv-6	1366	Pc	Bongo Hi 3Finger 1-2	1466	Pc	ChaCha	1566	Dr	Bd Dry1	1666	Dr	Bd ElecFx1	1766	Dr	Sd Normal St2-3
1267	Se	Ethnic Rhythm Rv-7	1367	Pc	Bongo Hi 3Finger 1	1467	Pc	Sleigh Bell	1567	Dr	Bd Dry2	1667	Dr	Bd ElecFX2	1767	Dr	Sd Normal St3-4
1268	Se	Ripper	1368	Pc	Bongo Hi 3Finger 2	1468	Pc	Wind Chime	1568	Dr	Bd Pop	1668	Dr	Bd ElecGate	1768	Dr	Sd Normal St1
1269	Se	Glass	1369	Pc	Bongo Hi Rim	1469	Pc	Clap T9	1569	Dr	Bd Var1	1669	Dr	Bd ElecClick	1769	Dr	Sd Normal 2St
1270	Se	Bell FX1	1370	Pc	Bongo Hi Tip	1470	Pc	Clap AnSm	1570	Dr	Bd Var2	1670	Dr	Bd ElecPower1	1770	Dr	Sd Normal 3St
1271	Se	Bell FX2	1371	Pc	Bongo Hi Heel	1471	Pc	Electric Clap1	1571	Dr	Bd Room1	1671	Dr	Bd ElecPower2	1771	Dr	Sd Normal 4St
1272	Se	IndusTom	1372	Pc	Bongo Hi Slap	1472	Pc	Electric Clap2	1572	Dr	Bd Room2	1672	Dr	Bd HipHop1	1772	Dr	Sd Normal L1-4
1273	Se	Noise Burst	1373	Pc	Bongo Lo 1Finger 1-2	1473	Pc	Conga T8	1573	Dr	Bd Room3	1673	Dr	Bd HipHop2	1773	Dr	Sd Normal R1-4
1274	Se	Zap1	1374	Pc	Bongo Lo 1Finger 1	1474	Pc	Cowbell T8	1574	Dr	Bd Jazz1-2St	1674	Dr	Bd HipHop3	1774	Dr	Sd Normal 1R
1275	Se	Zap2	1375	Pc	Bongo Lo 1Finger 2	1475	Pc	Cowbell RX11	1575	Dr	Bd Jazz1-2L	1675	Dr	Bd HipHop4	1775	Dr	Sd Normal 1R
1276	Se	Electric Perc1	1376	Pc	Bongo Lo 3Finger 1-2	1476	Pc	Cowbell AnCR	1576	Dr	Bd Jazz1-2R	1676	Dr	Bd HipHop5	1776	Dr	Sd Normal 2L
1277	Se	Electric Perc2	1377	Pc	Bongo Lo 3Finger 1	1477	Pc	Electric Cowbell	1577	Dr	Bd Jazz1St	1677	Dr	Bd HipHop6	1777	Dr	Sd Normal 2R
1278	Se	Electric Perc3	1378	Pc	Bongo Lo 3Finger 2	1478	Pc	Analog Shaker	1578	Dr	Bd Jazz1L	1678	Dr	Bd HipHop7	1778	Dr	Sd Normal 3L
1279	Se	Electric Perc4	1379	Pc	Bongo Lo Rim	1479	Pc	Tambourine RX5	1579	Dr	Bd Jazz1R	1679	Dr	Bd HipHop8	1779	Dr	Sd Normal 3R
1280	Se	Electric Perc5	1380	Pc	Bongo Lo Tip	1480	Pc	Tambourine AnCR	1580	Dr	Bd Jazz2St	1680	Dr	Bd HipHop9	1780	Dr	Sd Normal 4R
1281	Se	Electric Perc6	1381	Pc	Timbale Hi1-3	1481	Pc	Electric									

No	Category	Name	No	Category	Name	No	Category	Name	No	Category	Name	No	Category	Name	No	Category	Name
1801	Dr	Sd Basic St1-2	1901	Dr	Sd Rock Rim1 L	2001	Dr	Sd PowerD 3R	2101	Dr	Sd T9-5	2201	Dr	HH Pedal 2 L	2301	Dr	HH Power CIEgde 2St
1802	Dr	Sd Basic St2-3	1902	Dr	Sd Rock Rim1 R	2002	Dr	Sd PowerD 4St	2102	Dr	Sd T9Gate	2202	Dr	HH Pedal 3 L	2302	Dr	HH Power CIEgde 2L
1803	Dr	Sd Basic St1/3	1903	Dr	Sd Rock Open2 St	2003	Dr	Sd PowerD 4L	2103	Dr	Sd T9Rim	2203	Dr	HH Pedal 1 R	2303	Dr	HH Power CIEgde 2R
1804	Dr	Sd Basic 1St	1904	Dr	Sd Rock Open2 L	2004	Dr	Sd PowerD 4R	2104	Dr	Sd T8-1	2204	Dr	HH Pedal 2 R	2304	Dr	HH Power CIEgde 2RL
1805	Dr	Sd Basic 2St	1905	Dr	Sd Rock Open2 R	2005	Dr	Sd PowerD 5St	2105	Dr	Sd T8-2	2205	Dr	HH Pedal 3 R	2305	Dr	HH Power CIEgde 3St
1806	Dr	Sd Basic 3St	1906	Dr	Sd Rock Mute2 St	2006	Dr	Sd PowerD 5L	2106	Dr	Sd T8-3	2206	Dr	HH Pedal 1-3RL	2306	Dr	HH Power CIEgde 3L
1807	Dr	Sd Basic L1-3	1907	Dr	Sd Rock Mute2 L	2007	Dr	Sd PowerD 5R	2107	Dr	Sd T8-4	2207	Dr	HH Pedal 1 RL	2307	Dr	HH Power CIEgde 3R
1808	Dr	Sd Basic R1-3	1908	Dr	Sd Rock Mute2 R	2008	Dr	Sd Gate1	2108	Dr	Sd T8-5	2208	Dr	HH Pedal 2 RL	2308	Dr	HH Power CIEgde 3RL
1809	Dr	Sd Basic 1L	1909	Dr	Sd Rock Rim2 St	2009	Dr	Sd Gate2	2109	Dr	Sd T8 Rim	2209	Dr	HH Pedal 3 RL	2309	Dr	HH Power CIEgde 4St
1810	Dr	Sd Basic 1R	1910	Dr	Sd Rock Rim2 L	2010	Dr	Sd LdwHmono	2110	Dr	Sd AnSm	2210	Dr	HH Open 1-2St	2310	Dr	HH Power CIEgde 4L
1811	Dr	Sd Basic 2L	1911	Dr	Sd Rock Rim2 R	2011	Dr	Sd BreakRim	2111	Dr	Sd AnSm Rim	2211	Dr	HH Open 1St	2311	Dr	HH Power CIEgde 4R
1812	Dr	Sd Basic 2R	1912	Dr	Sd Rock Flam St	2012	Dr	Sd Dry	2112	Dr	Sd AnCR	2212	Dr	HH Open 2St	2312	Dr	HH Power CIEgde 4RL
1813	Dr	Sd Basic 3L	1913	Dr	Sd Rock Flam L	2013	Dr	Sd Heavy	2113	Dr	Sd AnCR Rim	2213	Dr	HH Open 1-2L	2313	Dr	HH Power CIPedal St
1814	Dr	Sd Basic 3R	1914	Dr	Sd Rock Flam R	2014	Dr	Sd GM	2114	Dr	Sd Human1	2214	Dr	HH Open 1-2R	2314	Dr	HH Power CIPedal R
1815	Dr	Sd SonA St1-4	1915	Dr	Sd Piccolo	2015	Dr	Sd Rock Stick1 St	2115	Dr	Sd Human2	2215	Dr	HH Open 1L	2315	Dr	HH Power CIPedal R
1816	Dr	Sd SonA St1-3	1916	Dr	Sd Piccolo Rim1	2016	Dr	Sd Rock Stick1 L	2116	Dr	Sd Jungle 1	2216	Dr	HH Open 2L	2316	Dr	HH Power CIPedal R
1817	Dr	Sd SonA St2-4	1917	Dr	Sd Piccolo Rim2	2017	Dr	Sd Rock Stick1 R	2117	Dr	Sd Jungle2	2217	Dr	HH Open 1R	2317	Dr	HH Power Open EdgeSt
1818	Dr	Sd SonA St1-2	1918	Dr	Sd Mid	2018	Dr	Sd Rock Stick2 St	2118	Dr	Sd Jungle3	2218	Dr	HH Open 2R	2318	Dr	HH Power Open EdgeL
1819	Dr	Sd SonA St2-3	1919	Dr	Sd Mid Rim	2019	Dr	Sd Rock Stick2 L	2119	Dr	Sd JungleFX	2219	Dr	HH Open 1-2RL	2319	Dr	HH Power Open EdgeR
1820	Dr	Sd SonA St3-4	1920	Dr	Sd Ambience	2020	Dr	Sd Rock Stick2 R	2120	Dr	Sd D&B1	2220	Dr	HH Open 1RL	2320	Dr	HH Power Open EdgeRL
1821	Dr	Sd SonA 1St	1921	Dr	Sd PowerA 1-5St	2021	Dr	Sd Hip Stick1	2121	Dr	Sd D&B2	2221	Dr	HH Open 2RL	2321	Dr	HH Brush Closed
1822	Dr	Sd SonA 2St	1922	Dr	Sd PowerA 1-5L	2022	Dr	Sd Hip Stick2	2122	Dr	Sd D&B3	2222	Dr	HH Closed Foot St	2322	Dr	HH Brush Open
1823	Dr	Sd SonA 3St	1923	Dr	Sd PowerA 1-5R	2023	Dr	Sd Hip Stick3	2123	Dr	Sd D&B4	2223	Dr	HH Closed Foot L	2323	Dr	HH Brush Pedal
1824	Dr	Sd SonA 4St	1924	Dr	Sd PowerA 1-4St	2024	Dr	Sd Hip Stick4	2124	Dr	Sd R&B1	2224	Dr	HH Closed Foot R	2324	Dr	HH Closed T9
1825	Dr	Sd SonA L1-4	1925	Dr	Sd PowerA 1-4L	2025	Dr	Sd Hip Stick5	2125	Dr	Sd R&B1 Rim	2225	Dr	HH Closed Foot S	2325	Dr	HH Open T9
1826	Dr	Sd SonA R1-4	1926	Dr	Sd PowerA 1-4R	2026	Dr	Sd Hip Stick6 St	2126	Dr	Sd R&B2	2226	Dr	HH Half Open2 St	2326	Dr	HH Closed T8-1
1827	Dr	Sd SonA 1L	1927	Dr	Sd PowerA 1St	2027	Dr	Sd Hip Stick6 L	2127	Dr	Sd Hip1	2227	Dr	HH Half Open2 L	2327	Dr	HH Open T8-1
1828	Dr	Sd SonA 1R	1928	Dr	Sd PowerA 1L	2028	Dr	Sd Hip Stick6 R	2128	Dr	Sd Hip2	2228	Dr	HH Half Open2 R	2328	Dr	HH Closed T8-2
1829	Dr	Sd SonA 2L	1929	Dr	Sd PowerA 1R	2029	Dr	Sd Hip Stick7	2129	Dr	Sd Hip3	2229	Dr	HH Half Open2 RL	2329	Dr	HH Open T8-2
1830	Dr	Sd SonA 2R	1930	Dr	Sd PowerA 2St	2030	Dr	Sd Hip Stick8	2130	Dr	Sd Hip Gate	2230	Dr	HH Open2 St	2330	Dr	HH Closed R5
1831	Dr	Sd SonA 3L	1931	Dr	Sd PowerA 2L	2031	Dr	Sd Closed Rim St	2131	Dr	Sd Hip Rim1	2231	Dr	HH Open2 L	2331	Dr	HH Closed AnCR
1832	Dr	Sd SonA 3R	1932	Dr	Sd PowerA 2R	2032	Dr	Sd Closed Rim L	2132	Dr	Sd Hip Rim2	2232	Dr	HH Open2 R	2332	Dr	HH Open AnCR
1833	Dr	Sd SonA 4L	1933	Dr	Sd PowerA 3St	2033	Dr	Sd Closed Rim R	2133	Dr	Sd Hip Rim3	2233	Dr	HH Open2 RL	2333	Dr	HH Closed Break
1834	Dr	Sd SonA 4R	1934	Dr	Sd PowerA 3L	2034	Dr	Sd Closed Rim2	2134	Dr	Sd Hip Rim4	2234	Dr	HH Closed Rock Sw St	2334	Dr	HH Pedal Break
1835	Dr	Sd Blues St1-3	1935	Dr	Sd PowerA 3R	2035	Dr	Sd Closed Rim3	2135	Dr	Sd Hip Rim5	2235	Dr	HH Closed Rock Sw RL	2335	Dr	HH Closed D&B
1836	Dr	Sd Blues St1-2	1936	Dr	Sd PowerA 4St	2036	Dr	Sd RockRoll St	2136	Dr	Sd Break1	2236	Dr	HH Closed Rock S St	2336	Dr	HH Pedal D&B
1837	Dr	Sd Blues St2-3	1937	Dr	Sd PowerA 4L	2037	Dr	Sd RockRoll L	2137	Dr	Sd Break2	2237	Dr	HH Closed Rock S RL	2337	Dr	HH Open D&B
1838	Dr	Sd Blues St1/3	1938	Dr	Sd PowerA 4R	2038	Dr	Sd RockRoll R	2138	Dr	Sd Break3	2238	Dr	HH Closed Rock H St	2338	Dr	HH Reverse D&B
1839	Dr	Sd Blues 1St	1939	Dr	Sd PowerA 5St	2039	Dr	Sd RockRollD St	2139	Dr	Sd Break Heavy	2239	Dr	HH Closed Rock H RL	2339	Dr	HH Closed Tek
1840	Dr	Sd Blues 2St	1940	Dr	Sd PowerA 5L	2040	Dr	Sd RockRollD L	2140	Dr	Sd Break Roll	2240	Dr	HH Closed Rock Sw L	2340	Dr	HH Open Tek
1841	Dr	Sd Blues 3St	1941	Dr	Sd PowerA 5R	2041	Dr	Sd RockRollD R	2141	Dr	Sd FX1	2241	Dr	HH Closed Rock Sw R	2341	Dr	HH Closed Hip
1842	Dr	Sd Blues L1-3	1942	Dr	Sd PowerB 1-5St	2042	Dr	Sd LiveRoll St	2142	Dr	Sd FX2	2242	Dr	HH Closed Rock S L	2342	Dr	HH Pedal Hip
1843	Dr	Sd Blues R1-3	1943	Dr	Sd PowerB 1-5L	2043	Dr	Sd LiveRoll L	2143	Dr	Sd FX3	2243	Dr	HH Closed Rock S R	2343	Dr	HH Open Hip
1844	Dr	Sd Blues 1L	1944	Dr	Sd PowerB 1-5R	2044	Dr	Sd LiveRoll R	2144	Dr	Sd FX4	2244	Dr	HH Closed Rock H L	2344	Dr	HH Closed Lo-Fi
1845	Dr	Sd Blues 1R	1945	Dr	Sd PowerB 1-4St	2045	Dr	Sd Roll Mono	2145	Dr	Sd ClapAna	2245	Dr	HH Closed Rock H R	2345	Dr	HH Open Lo-Fi
1846	Dr	Sd Blues 2L	1946	Dr	Sd PowerB 1-4L	2046	Dr	Sd Brush Soft St	2146	Dr	Sd Dist	2246	Dr	HH Pedal Rock Sw St	2346	Dr	HH Closed Syn
1847	Dr	Sd Blues 2R	1947	Dr	Sd PowerB 1-4R	2047	Dr	Sd Brush Soft L	2147	Dr	Sd Cut	2247	Dr	HH Pedal Rock Sw RL	2347	Dr	HH Open Syn
1848	Dr	Sd Blues 3L	1948	Dr	Sd PowerB 1St	2048	Dr	Sd Brush Soft R	2148	Dr	Sd Garg H	2248	Dr	HH Pedal Rock Sw L	2348	Dr	HH Closed FX
1849	Dr	Sd Blues 3R	1949	Dr	Sd PowerB 1L	2049	Dr	Sd Brush Med St	2149	Dr	Sd Garg L	2249	Dr	HH Pedal Rock Sw R	2349	Dr	HH Open FX
1850	Dr	Sd BluesHeart St1-3	1950	Dr	Sd PowerB 1R	2050	Dr	Sd Brush Med L	2150	Dr	Sd FM	2250	Dr	HH Closed Rock 2St	2350	Dr	HH Open Human
1851	Dr	Sd BluesHeart St1-2	1951	Dr	Sd PowerB 2St	2051	Dr	Sd Brush Med R	2151	Dr	Sd FM Rim	2251	Dr	HH Closed Rock 2L	2351	Dr	Tom Hi St
1852	Dr	Sd BluesHeart St2-3	1952	Dr	Sd PowerB 2L	2052	Dr	Sd Brush vari St	2152	Dr	Sd Syn	2252	Dr	HH Closed Rock 2R	2352	Dr	Tom Hi L
1853	Dr	Sd BluesHeart St1/3	1953	Dr	Sd PowerB 2R	2053	Dr	Sd Brush vari L	2153	Dr	Sd Clappy	2253	Dr	HH Closed Rock 2RL	2353	Dr	Tom Hi R
1854	Dr	Sd BluesHeart 1St	1954	Dr	Sd PowerB 3St	2054	Dr	Sd Brush vari R	2154	Dr	Sd Timbr	2254	Dr	HH Pedal Rock St	2354	Dr	Tom Hi RL
1855	Dr	Sd BluesHeart 2St	1955	Dr	Sd PowerB 3L	2055	Dr	Sd Closed Rim4 St	2155	Dr	Sd Wood	2255	Dr	HH Pedal Rock L	2355	Dr	Tom Mid St
1856	Dr	Sd BluesHeart 3St	1956	Dr	Sd PowerB 3R	2056	Dr	Sd Closed Rim4 L	2156	Dr	Sd Hammer	2256	Dr	HH Pedal Rock R	2356	Dr	Tom Mid L
1857	Dr	Sd BluesHeart L1-3	1957	Dr	Sd PowerB 4St	2057	Dr	Sd Closed Rim4 R	2157	Dr	Sd Lo-Fi	2257	Dr	HH Pedal Rock RL	2357	Dr	Tom Mid R
1858	Dr	Sd BluesHeart R1-3	1958	Dr	Sd PowerB 4L	2058	Dr	Sd Brush Swir St	2158	Dr	Sd Rim SE	2258	Dr	HH Open Rock Sw St	2358	Dr	Tom Mid RL
1859	Dr	Sd BluesHeart 1L	1959	Dr	Sd PowerB 4R	2059	Dr	Sd Brush Swir L	2159	Dr	Sd HipHop1	2259	Dr	HH Open Rock Sw RL	2359	Dr	Tom Low St
1860	Dr	Sd BluesHeart 1R	1960	Dr	Sd PowerB 5St	2060	Dr	Sd Brush Swir R	2160	Dr	Sd HipHop2	2260	Dr	HH Open Rock Sw L	2360	Dr	Tom Low L
1861	Dr	Sd BluesHeart 2L	1961	Dr	Sd PowerB 5L	2061	Dr	Sd Brush SwirAtt St	2161	Dr	Sd HipHop3	2261	Dr	HH Open Rock RL	2361	Dr	Tom Low R
1862	Dr	Sd BluesHeart 2R	1962	Dr	Sd PowerB 5R	2062	Dr	Sd Brush SwirAtt L	2162	Dr	Sd HipHop5	2262	Dr	HH Half Open Rock St	2362	Dr	Tom Low RL
1863	Dr	Sd BluesHeart 3L	1963	Dr	Sd PowerB 5St	2063	Dr	Sd Brush SwirAtt R	2163	Dr	Sd HipHop6	2263	Dr	HH Open Rock Sw L	2363	Dr	Tom Floor St
1864	Dr	Sd BluesHeart 3R	1964	Dr	Sd PowerB 5L	2064	Dr	Sd Orch1 Sw St	2164	Dr	Sd HipHop7	2264	Dr	HH Open Rock Sw R	2364	Dr	Tom Floor L
1865	Dr	Sd Tight St1-4	1965	Dr	Sd PowerB SR	2065	Dr	Sd Orch1 S St	2165	Dr	Sd HipHop9	2265	Dr	HH Open Rock R	2365	Dr	Tom Floor R
1866	Dr	Sd Tight St1-3	1966	Dr	Sd PowerC 1-5St	2066	Dr	Sd Orch1 H St	2166	Dr	Sd HipHop10	2266	Dr	HH Open Rock L	2366	Dr	Tom Floor RL
1867	Dr	Sd Tight St2-4	1967	Dr	Sd PowerC 1-5L	2067	Dr	Sd Orch1 Sw L	2167	Dr	Sd HipHop11	2267	Dr	HH Half Open Rock L	2367	Dr	Tom Rock Hi St
1868	Dr	Sd Tight St1-2	1968	Dr	Sd PowerC 1-5R	2068	Dr	Sd Orch1 Sw R	2168	Dr	Sd HipHop Rim1	2268	Dr	HH Half Open Rock R	2368	Dr	Tom Rock Hi RL
1869	Dr	Sd Tight St2-3	1969	Dr	Sd PowerC 1-4St	2069	Dr	Sd Orch1 S L	2169	Dr	Sd HipHop Rim2	2269	Dr	HH Half Open Rock RL	2369	Dr	Tom Rock Hi R
1870	Dr	Sd Tight St3-4	1970	Dr	Sd PowerC 1-4L	2070	Dr	Sd Orch1 H L	2170	Dr	Sd HipHop Rim3	2270	Dr	HH Closed Mono	2370	Dr	Tom Rock Hi St
1871	Dr	Sd Tight 1St	1971	Dr	Sd PowerC 1-4R	2071	Dr	Sd Orch1 S R	2171	Dr	Sd HipHop Rim4	2271	Dr	HH Open Mono	2371	Dr	Tom Rock Mid St
1872	Dr	Sd Tight 2St	1972	Dr	Sd PowerC 1St	2072	Dr	Sd Orch1 H R	2172	Dr	Sd HipHop Rim5	2272	Dr	HH Pedal Mono	2372	Dr	Tom Rock Mid L
1873	Dr	Sd Tight 3St	1973	Dr	Sd PowerC 1L	2073	Dr	Sd Orch2 SwSt	2173	Dr	Sd HipHop Rim6	2273	Dr	HH Power CItip 1-4St	2373	Dr	Tom Rock Mid RL
1874	Dr	Sd Tight 4St	1974	Dr	Sd PowerC 1R	2074	Dr	Sd Orch2 S St	2174	Dr	HH Closed 1-4St	2274	Dr	HH Power CItip 1-4L	2374	Dr	Tom Rock Mid R
1875	Dr	Sd Tight L1-4	1975	Dr	Sd PowerC 2St	2075	Dr	Sd Orch2 H St	2175	Dr	HH Closed 1St	2275	Dr	HH Power CItip 1-4R	2375	Dr	Tom Rock Low St
1876	Dr	Sd Tight R1-4	1976	Dr	Sd PowerC 2L	2076	Dr	Sd Orch2 Sw L	2176	Dr	HH Closed 2St	2276	Dr	HH Power CItip 1-4RL	2376	Dr	Tom Rock Low L
1877	Dr	Sd Tight 1L	1977	Dr	Sd PowerC 2R	2077	Dr	Sd Orch2 Sw R	2177	Dr	HH Closed 3St	2277	Dr	HH Power CItip 1St	2377	Dr	Tom Rock Low R
1878	Dr	Sd Tight 1R	1978	Dr	Sd PowerC 3St	2078	Dr	Sd Orch2 S L	2178	Dr	HH Closed 4St	2278	Dr	HH Power CItip 1L	2378	Dr	Tom Rock Low RL
1879	Dr	Sd Tight 1R	1979	Dr	Sd PowerC 3L												

No	Category	Name	No	Category	Name	No	Category	Name
2401	Dr	Tom Power03 2R	2501	Dr	Ride Brush2 St	2601	Se	AcousticGtr FX26 St
2402	Dr	Tom Power03 2RL	2502	Dr	Ride Brush2 L	2602	Se	AcousticGtr FX26 L
2403	Dr	Tom Power04 1-2St	2503	Dr	Ride Brush2 R	2603	Se	AcousticGtr FX26 R
2404	Dr	Tom Power04 1-2L	2504	Dr	Ride Brush2 RL	2604	Se	AcousticGtr FX27 St
2405	Dr	Tom Power04 1-2R	2505	Dr	Ride Cup2 St	2605	Se	AcousticGtr FX27 L
2406	Dr	Tom Power04 1-2RL	2506	Dr	Ride Cup2 L	2606	Se	AcousticGtr FX27 R
2407	Dr	Tom Power04 1St	2507	Dr	Ride Cup2 R	2607	Se	AcousticGtr FX28 St
2408	Dr	Tom Power04 1L	2508	Dr	Ride Cup2 RL	2608	Se	AcousticGtr FX28 L
2409	Dr	Tom Power04 1R	2509	Dr	Ride Mono	2609	Se	AcousticGtr FX28 R
2410	Dr	Tom Power04 1RL	2510	Dr	Ride Cup Mono	2610	Se	AcousticGtr FX29 St
2411	Dr	Tom Power04 2St	2511	Dr	Ride Cup Mono2	2611	Se	AcousticGtr FX29 L
2412	Dr	Tom Power04 2L	2512	Dr	China St	2612	Se	AcousticGtr FX29 R
2413	Dr	Tom Power04 2R	2513	Dr	China L	2613	Se	AcousticGtr FX30 St
2414	Dr	Tom Power04 2RL	2514	Dr	China R	2614	Se	AcousticGtr FX30 L
2415	Dr	Tom Power05 1-2St	2515	Dr	China RL	2615	Se	AcousticGtr FX30 R
2416	Dr	Tom Power05 1-2L	2516	Dr	China2	2616	Se	ElectricGtr FX01
2417	Dr	Tom Power05 1-2R	2517	Dr	Splash St	2617	Se	ElectricGtr FX02
2418	Dr	Tom Power05 1-2RL	2518	Dr	Splash L	2618	Se	ElectricGtr FX03
2419	Dr	Tom Power05 1St	2519	Dr	Splash R	2619	Se	ElectricGtr FX04
2420	Dr	Tom Power05 1L	2520	Dr	Splash RL	2620	Se	ElectricGtr FX05
2421	Dr	Tom Power05 1R	2521	Dr	Crash T9	2621	Se	ElectricGtr FX06
2422	Dr	Tom Power05 1RL	2522	Dr	Crash T8	2622	Se	ElectricGtr FX07
2423	Dr	Tom Power05 2St	2523	Dr	Crash Syn	2623	Se	ElectricGtr FX08
2424	Dr	Tom Power05 2L	2524	Dr	Ride T9	2624	Se	ElectricGtr FX09
2425	Dr	Tom Power05 2R	2525	Dr	Reverse Cymbal	2625	Se	ElectricGtr FX10
2426	Dr	Tom Power05 2RL	2526	Se	AcousticGtr FX01 St	2626	Se	ElectricGtr FX11
2427	Dr	Tom Brush Hi St	2527	Se	AcousticGtr FX01 L	2627	Se	ElectricGtr FX12
2428	Dr	Tom Brush Hi L	2528	Se	AcousticGtr FX01 R	2628	Se	ElectricGtr FX13
2429	Dr	Tom Brush Hi R	2529	Se	AcousticGtr FX02 St	2629	Se	ElectricGtr FX14
2430	Dr	Tom Brush Hi RL	2530	Se	AcousticGtr FX02 L	2630	Se	ElectricGtr FX15
2431	Dr	Tom Brush Mid St	2531	Se	AcousticGtr FX02 R	2631	Se	ElectricGtr FX16
2432	Dr	Tom Brush Mid L	2532	Se	AcousticGtr FX03 St	2632	Se	ElectricGtr FX17
2433	Dr	Tom Brush Mid R	2533	Se	AcousticGtr FX03 L	2633	Se	ElectricGtr FX18
2434	Dr	Tom Brush Mid RL	2534	Se	AcousticGtr FX03 R	2634	Se	ElectricGtr FX19
2435	Dr	Tom Brush Low St	2535	Se	AcousticGtr FX04 St	2635	Se	ElectricGtr FX20
2436	Dr	Tom Brush Low L	2536	Se	AcousticGtr FX04 L	2636	Se	ElectricGtr FX21
2437	Dr	Tom Brush Low R	2537	Se	AcousticGtr FX04 R	2637	Se	ElectricGtr FX22
2438	Dr	Tom Brush Low RL	2538	Se	AcousticGtr FX05 St	2638	Se	ElectricGtr FX23
2439	Dr	Tom Brush floor St	2539	Se	AcousticGtr FX05 L	2639	Se	Acoustic Bass FX01
2440	Dr	Tom Brush Floor L	2540	Se	AcousticGtr FX05 R	2640	Se	Acoustic Bass FX02
2441	Dr	Tom Brush Floor R	2541	Se	AcousticGtr FX06 St	2641	Se	Acoustic Bass FX03
2442	Dr	Tom Brush Floor RL	2542	Se	AcousticGtr FX06 L	2642	Se	Acoustic Bass FX04
2443	Dr	Tom Mono Hi	2543	Se	AcousticGtr FX06 R	2643	Se	Acoustic Bass FX05
2444	Dr	Tom Mono Lo	2544	Se	AcousticGtr FX07 St	2644	Se	Acoustic Bass FX06
2445	Dr	Tom Dry Hi	2545	Se	AcousticGtr FX07 L	2645	Se	Acoustic Bass FX07
2446	Dr	Tom Dry Lo	2546	Se	AcousticGtr FX07 R	2646	Se	Acoustic Bass FX08
2447	Dr	Tom Ambience Hi	2547	Se	AcousticGtr FX08 St	2647	Se	Acoustic Bass FX09
2448	Dr	Tom Ambience Lo	2548	Se	AcousticGtr FX08 L	2648	Se	Electric Bass FX 01
2449	Dr	Tom T9 Hi	2549	Se	AcousticGtr FX08 R	2649	Se	Electric Bass FX 02
2450	Dr	Tom T9 Lo	2550	Se	AcousticGtr FX09 St	2650	Se	Electric Bass FX 03
2451	Dr	Tom T8	2551	Se	AcousticGtr FX09 L	2651	Se	Electric Bass FX 04
2452	Dr	Tom Syn1	2552	Se	AcousticGtr FX09 R	2652	Se	Electric Bass FX 05
2453	Dr	Tom Syn2	2553	Se	AcousticGtr FX10 St	2653	Se	Electric Bass FX 06
2454	Dr	Tom AnSm	2554	Se	AcousticGtr FX10 L	2654	Se	Electric Bass FX 07
2455	Dr	Tom Dist Hi	2555	Se	AcousticGtr FX10 R	2655	Se	Electric Bass FX 08
2456	Dr	Tom Dist Lo	2556	Se	AcousticGtr FX11 St	2656	Se	Electric Bass FX 09
2457	Dr	Crash1 St	2557	Se	AcousticGtr FX11 L	2657	Se	Electric Bass FX 10
2458	Dr	Crash1 L	2558	Se	AcousticGtr FX11 R	2658	Se	Electric Bass FX 11
2459	Dr	Crash1 R	2559	Se	AcousticGtr FX12 St	2659	Se	Electric Bass FX 12
2460	Dr	Crash1 RL	2560	Se	AcousticGtr FX12 L	2660	Se	Electric Bass FX 13
2461	Dr	Crash2 St	2561	Se	AcousticGtr FX12 R	2661	Se	Electric Bass FX 14
2462	Dr	Crash2 L	2562	Se	AcousticGtr FX13 St	2662	Se	Electric Bass FX 15
2463	Dr	Crash2 R	2563	Se	AcousticGtr FX13 L	2663	Se	Electric Bass FX 16
2464	Dr	Crash2 RL	2564	Se	AcousticGtr FX13 R	2664	Se	Electric Bass FX 17
2465	Dr	Crash3	2565	Se	AcousticGtr FX14 St	2665	Se	Electric Bass FX 18
2466	Dr	Crash4	2566	Se	AcousticGtr FX14 L	2666	Se	Electric Bass FX 19
2467	Dr	Crash Brush1 St	2567	Se	AcousticGtr FX14 R	2667	Se	Electric Bass FX 20
2468	Dr	Crash Brush1 L	2568	Se	AcousticGtr FX15 St	2668	Se	Electric Bass FX 21
2469	Dr	Crash Brush1 R	2569	Se	AcousticGtr FX15 L	2669	Se	Electric Bass FX 22
2470	Dr	Crash Brush1 RL	2570	Se	AcousticGtr FX15 R	2670	Se	Electric Bass FX 23
2471	Dr	Crash Brush Cup St	2571	Se	AcousticGtr FX16 St			
2472	Dr	Crash Brush Cup L	2572	Se	AcousticGtr FX16 L			
2473	Dr	Crash Brush Cup R	2573	Se	AcousticGtr FX16 R			
2474	Dr	Crash Brush Cup RL	2574	Se	AcousticGtr FX17 St			
2475	Dr	Crash Brush2 St	2575	Se	AcousticGtr FX17 L			
2476	Dr	Crash Brush2 L	2576	Se	AcousticGtr FX17 R			
2477	Dr	Crash Brush2 R	2577	Se	AcousticGtr FX18 St			
2478	Dr	Crash Brush2 RL	2578	Se	AcousticGtr FX18 L			
2479	Dr	Hand Cymbal Open St	2579	Se	AcousticGtr FX18 R			
2480	Dr	Hand Cymbal Open L	2580	Se	AcousticGtr FX19 St			
2481	Dr	Hand Cymbal Open R	2581	Se	AcousticGtr FX19 L			
2482	Dr	Hand Cymbal Mute St	2582	Se	AcousticGtr FX19 R			
2483	Dr	Hand Cymbal Mute L	2583	Se	AcousticGtr FX20 St			
2484	Dr	Hand Cymbal Mute R	2584	Se	AcousticGtr FX20 L			
2485	Dr	Ride1 St	2585	Se	AcousticGtr FX20 R			
2486	Dr	Ride1 L	2586	Se	AcousticGtr FX21 St			
2487	Dr	Ride1 R	2587	Se	AcousticGtr FX21 L			
2488	Dr	Ride1 RL	2588	Se	AcousticGtr FX21 R			
2489	Dr	Ride2 St	2589	Se	AcousticGtr FX22 St			
2490	Dr	Ride2 L	2590	Se	AcousticGtr FX22 L			
2491	Dr	Ride2 R	2591	Se	AcousticGtr FX22 R			
2492	Dr	Ride2 RL	2592	Se	AcousticGtr FX23 St			
2493	Dr	Ride Cup1 St	2593	Se	AcousticGtr FX23 L			
2494	Dr	Ride Cup1 L	2594	Se	AcousticGtr FX23 R			
2495	Dr	Ride Cup1 R	2595	Se	AcousticGtr FX24 St			
2496	Dr	Ride Cup1 RL	2596	Se	AcousticGtr FX24 L			
2497	Dr	Ride Brush1 St	2597	Se	AcousticGtr FX24 R			
2498	Dr	Ride Brush1 L	2598	Se	AcousticGtr FX25 St			
2499	Dr	Ride Brush1 R	2599	Se	AcousticGtr FX25 L			
2500	Dr	Ride Brush1 RL	2600	Se	AcousticGtr FX25 R			

Performance List

USR1 (MSB=63, LSB=64)

Number	Performance Name	Perf. Category	Subcategory	
1	A01	Chilltronika	Elect	Chill
2	A02	East Sider	R&B	HipHp
3	A03	Dreamscape	SpLyr	Symph
4	A04	Sub-sonic	Elect	Chill
5	A05	Chilln Keys	Elect	Chill
6	A06	Urban Shuffle	Rock	Clsic
7	A07	Green Oasis	SpLyr	Pad
8	A08	Andy Lucia	World	Latin
9	A09	Heart Breakz	Elect	Trnce
10	A10	Bop till you Drop	Jazz	Modrn
11	A11	White Sand Dub	Elect	Chill
12	A12	Double Dip the Funk	R&B	Funk
13	A13	Dark Continent	Rock	Clsic
14	A14	Electro Club	Elect	Tekno
15	A15	Slow and Low	R&B	HipHp
16	A16	Abyss of the Sea	FX	Seq
17	B01	Second Breakfast	Elect	Chill
18	B02	Coastal	R&B	HipHp
19	B03	Semi Finale	SpLyr	Symph
20	B04	DRY-Wash	Elect	Tekno
21	B05	Warm Feeling	Elect	Chill
22	B06	Strummin'&Hummin'	Rock	Cntry
23	B07	Ukigumo	FX	Seq
24	B08	Bellydancer	World	Ethno
25	B09	Chart Breaker	Elect	Trnce
26	B10	Smooth It Over	Jazz	Smoth
27	B11	Sample & Hold	FX	Seq
28	B12	Funky Finger	R&B	Funk
29	B13	Yearn to see You	SpLyr	Synth
30	B14	Big Beater	Elect	Tekno
31	B15	Organ Cruise	R&B	Funk
32	B16	Oyashio	FX	S.EFX
33	C01	Synth Power	Rock	Top40
34	C02	Yah-Yo-Jah	R&B	HipHp
35	C03	Trumpet Concert	SpLyr	Brass
36	C04	Dancing Bars	Rock	Clsic
37	C05	Nightshadows	Elect	Chill
38	C06	Hold On a Minute	R&B	Clsic
39	C07	Kogarashi	FX	Soft
40	C08	Hot Sauce	World	Latin
41	C09	Cosmic Trance	Elect	Trnce
42	C10	Blues Organ Trio	Jazz	Swing
43	C11	Jembrana	FX	Seq
44	C12	Clavi Jam	R&B	Funk
45	C13	Free Fall	Rock	Clsic
46	C14	Tollhouse	Elect	Tekno
47	C15	String Accompaniment	SpLyr	Piano
48	C16	Arianes Nightwalk	FX	Seq
49	D01	Semar Dub	Elect	Chill
50	D02	Casbian Nights	R&B	HipHp
51	D03	Requiem	SpLyr	Symph
52	D04	Broiling	Elect	Tekno
53	D05	Wobbly Keys	Elect	Chill
54	D06	Rock of the 80's	Rock	Hard
55	D07	Crying Scene	SpLyr	Pad
56	D08	Two Hands of Latin	World	Latin
57	D09	Funfair	Elect	Trnce
58	D10	Night Cruiser	Jazz	Smoth
59	D11	Meeting Point	FX	Seq
60	D12	Analog Power	R&B	Funk
61	D13	Sarah's Dream	SpLyr	Synth
62	D14	Pursuer	Elect	Tekno
63	D15	Worship	R&B	Clsic
64	D16	Euro Animation	SpLyr	Brass

Number	Performance Name	Perf. Category	Subcategory	
65	E01	Poppyhanger	Elect	Chill
66	E02	Neighborhood	R&B	HipHp
67	E03	Winds & Strings	SpLyr	WWind
68	E04	Deep House 1	Elect	House
69	E05	Wet Reflected Lights	Elect	Chill
70	E06	Classic Shuffle Rock	Rock	Clsic
71	E07	Silent Spheres	SpLyr	Pad
72	E08	Multi-Cultural	World	Ethno
73	E09	Cool Box	Elect	Tekno
74	E10	Let's Comp!	Jazz	Swing
75	E11	Kuroshio	FX	Seq
76	E12	Acid Club	Jazz	Club
77	E13	Haze o' Phase	Elect	Tekno
78	E14	Gran Beat	Elect	Tekno
79	E15	Lake Side	SpLyr	Piano
80	E16	Sprinkler	FX	Soft
81	F01	Dub City	Elect	D&B
82	F02	West Coast Interact	R&B	HipHp
83	F03	Oboe Soloist	SpLyr	WWind
84	F04	Electric Monkeys	Elect	Tekno
85	F05	Chilly Dreams	Elect	Chill
86	F06	Echo Park Rock	Rock	Balad
87	F07	Angel Pad	SpLyr	Pad
88	F08	Latin 4 Beginners	World	Latin
89	F09	What is he doing?	Elect	Tekno
90	F10	Duck Groove	Jazz	Smoth
91	F11	Java Winds	FX	Seq
92	F12	Funky Jump	R&B	Funk
93	F13	Club Jazz 1	Jazz	Club
94	F14	Machine-Run	Elect	Tekno
95	F15	Full Monty	SpLyr	Organ
96	F16	Kyuketsuki	FX	S.EFX
97	G01	Auto Running	Elect	Chill
98	G02	Bubblicious	R&B	Modrn
99	G03	The Woodwind Section	SpLyr	WWind
100	G04	Maison Blanc	Elect	House
101	G05	Bristol	Elect	Chill
102	G06	Friday Night	Rock	Clsic
103	G07	Lake Pad	SpLyr	Pad
104	G08	Canto de rua	World	Latin
105	G09	Pound-a-thon	Elect	Tekno
106	G10	Film Noir	Jazz	Swing
107	G11	Teatime	FX	Seq
108	G12	Funk Jam	R&B	Funk
109	G13	Rattle and Roll	R&B	HipHp
110	G14	Club 80's	Elect	Tekno
111	G15	2 Manuals	SpLyr	Organ
112	G16	Needle Penalty	FX	S.EFX
113	H01	Magic Spell	Elect	Trnce
114	H02	The Duece	R&B	HipHp
115	H03	Movie Strings	SpLyr	Strng
116	H04	Nasty Dirty Funky	Elect	House
117	H05	Traumzeit	Elect	Chill
118	H06	Austin City Blues	Rock	Clsic
119	H07	Creepn Worm	SpLyr	Pad
120	H08	2 Guitars for Mrs R	World	Latin
121	H09	Subway Traxx Trigger	Elect	Trnce
122	H10	Dream Shuffle	Rock	Top40
123	H11	Snow na Oto	FX	Seq
124	H12	Thrust	Jazz	Smoth
125	H13	Elfin Dreams	Elect	Chill
126	H14	Crowded Place	Elect	Tekno
127	H15	American Beauty	SpLyr	Piano
128	H16	Space Gallery	FX	Soft

USR2 (MSB=63, LSB=65)

Number	Performance Name	Category	Sub Category	
1	A01	Dresden At Night	Elect	Chill
2	A02	Epik	R&B	HipHp
3	A03	Antarctic Moments	SpLyr	Pad
4	A04	Star Power	Rock	Hard
5	A05	Automatic Rap	R&B	HipHp
6	A06	Patrol	Rock	Top40
7	A07	He doesn't see you.	SpLyr	Piano
8	A08	Balkan Blitz	World	Ethno
9	A09	Dark Wind	Elect	Tekno
10	A10	Funkhunters	Jazz	JzFnk
11	A11	Club 4.15 AM	Elect	Tekno
12	A12	Bouncing HH	R&B	Modrn
13	A13	Made in Russia	Rock	Top40
14	A14	Electrode	Elect	Trnce
15	A15	Dirty Pop R&B	R&B	Modrn
16	A16	The Mother Ship	FX	Seq
17	B01	Snow in Havana	Elect	Chill
18	B02	C'mon Mr. DeeJay!	R&B	Modrn
19	B03	Subcutaneous Stress	SpLyr	Pad
20	B04	ConcretePalaceAirmen	Rock	Hard
21	B05	Minimal Hop	R&B	HipHp
22	B06	Jack Does it Again	Rock	Clsic
23	B07	Standing on Air	SpLyr	Pad
24	B08	Rodovia	World	Latin
25	B09	Program Counter MOD	Elect	Chill
26	B10	Hey Sixteen	Jazz	JzFnk
27	B11	Riot Squad	Elect	Chill
28	B12	Funk Night	R&B	Funk
29	B13	DigiRock	Rock	Top40
30	B14	Rubbish Rain	Elect	Tekno
31	B15	CV & Gate	R&B	HipHp
32	B16	Orchestra Del Mar	FX	Seq
33	C01	Chillin Mo	Elect	Chill
34	C02	Capital City	R&B	HipHp
35	C03	Windowshopping	SpLyr	Pad
36	C04	Hair and Guitars	Rock	Hard
37	C05	Drama	R&B	HipHp
38	C06	Surfin' Kahuna	Rock	Clsic
39	C07	Nervous?	SpLyr	Pad
40	C08	Bossa On the Beach	World	Latin
41	C09	Electronica Resort	Elect	Tekno
42	C10	Jazz Quartet	Jazz	Modrn
43	C11	Techno Bells	Elect	Tekno
44	C12	Down Wid It Trigger	R&B	HipHp
45	C13	Compse UR Hit	Rock	Clsic
46	C14	Psychic Trance	Elect	Trnce
47	C15	Tilt the Brim	R&B	HipHp
48	C16	Arp Foundation	FX	Seq
49	D01	Santa Eularia Sunset	Elect	Chill
50	D02	Head Full of Rock	R&B	HipHp
51	D03	Iceage Piano	SpLyr	Piano
52	D04	Visual K++	Rock	Hard
53	D05	Sippin on it MOD	R&B	HipHp
54	D06	Macaroni	Rock	Top40
55	D07	All Guitars	SpLyr	Guitr
56	D08	La Isla del Encanto	World	Latin
57	D09	Sneaky Neutrons	Elect	Chill
58	D10	Just the Facts	Jazz	JzFnk
59	D11	Rebooting...	Elect	Tekno
60	D12	Soul For Waltz	R&B	Clsic
61	D13	Psychedelic Dream	Rock	Clsic
62	D14	Deep House 2	Elect	House
63	D15	Stake Out	R&B	HipHp
64	D16	Welcome to Sirius	FX	Soft

Number	Performance Name	Category	Sub Category	
65	E01	Crushy Jegog	Elect	Chill
66	E02	Don't Go No Mo	R&B	HipHp
67	E03	Philharmonic	SpLyr	Symph
68	E04	Contemporary Rock	Rock	Top40
69	E05	Instant Camera	R&B	Modrn
70	E06	Slow Blues	Rock	Blues
71	E07	Campfire Split	SpLyr	Guitr
72	E08	Martini Orbit	World	Latin
73	E09	Wah Dub	Elect	Chill
74	E10	Smooth Lead Jam	Jazz	Smoth
75	E11	Electricity	Elect	Tekno
76	E12	Money on My Mind	R&B	HipHp
77	E13	Do U know I-o-y?	Rock	Balad
78	E14	W Sweep	Elect	Tekno
79	E15	You fill me MOD	R&B	HipHp
80	E16	Triathlon	FX	Seq
81	F01	ChillOut noises	Elect	Chill
82	F02	Exit Inglewood	R&B	HipHp
83	F03	Jazz Duo	SpLyr	Piano
84	F04	16beat Rock	Rock	Hard
85	F05	Zyche-Out	R&B	Modrn
86	F06	Lay Me Down to Sleep	Rock	Balad
87	F07	ARP Piano Concerto	SpLyr	Piano
88	F08	Meringue	World	Latin
89	F09	Glass Work	Elect	Chill
90	F10	Rag Time Strut(4ARP)	Jazz	Swing
91	F11	Power Worxx	Elect	Tekno
92	F12	Far Away from Home	FX	Seq
93	F13	Classic Rock	Rock	Clsic
94	F14	Long Dark Tunnel	Elect	D&B
95	F15	Vanilla Wrapper	R&B	HipHp
96	F16	Ethereal	FX	Soft
97	G01	Beatstreet!	Elect	Tekno
98	G02	Eighth Dot	R&B	HipHp
99	G03	Guitar+PianoBallad	SpLyr	Guitr
100	G04	Alternative2 Trigger	Rock	Hard
101	G05	Mrs Independent	R&B	Modrn
102	G06	Fretless Ballad	Rock	Balad
103	G07	The March of Progres	SpLyr	Symph
104	G08	Asahi ni niou	World	Ethno
105	G09	Contemplation	Elect	Chill
106	G10	Jumpin' Jive Organ	Jazz	JzFnk
107	G11	Automation	Elect	Chill
108	G12	Bell Doesn't Ring	FX	Hard
109	G13	Girls Folk	Rock	Folk
110	G14	Power Lines	Elect	Tekno
111	G15	Regeton (4ARP)	R&B	HipHp
112	G16	971 Nightflight	FX	Seq
113	H01	Implant	Elect	Trnce
114	H02	No NY Sleep	R&B	HipHp
115	H03	Ballad Piano&Bass	SpLyr	Piano
116	H04	80's young gun	Rock	Clsic
117	H05	Jam For What?!	R&B	Clsic
118	H06	Blues Spell	Rock	Blues
119	H07	Bach o' Roll	SpLyr	Symph
120	H08	Guitar Duo	World	Latin
121	H09	Dust of Mars	Elect	Chill
122	H10	Late Walk	Jazz	Smoth
123	H11	Straight Line	Elect	Trnce
124	H12	Nuclear Fusion	FX	S.EFX
125	H13	Wild Heart	Rock	Clsic
126	H14	Latin House	Elect	House
127	H15	J Funk	R&B	Funk
128	H16	turn the wheels...	FX	Seq

Master Assign List

Master No.	Master Name	Mode	Bank Name	Program Number
1	MO Xpressive	Performance	User2	1
2	Full Concert Grand	Voice	Normal Pre1	1
3	Classical AF1&2	Voice	Normal Pre2	50
4	East Sider	Performance	User1	2
5	Rock of the 80's	Performance	User1	54
6	Dark Continent	Performance	User1	13
7	Quick Bows	Voice	Normal Pre4	16
8	Club WorX	Song	---	1
9	Bop till you Drop	Performance	User1	10
10	Rubbish Rain	Performance	User2	30
11	DRY-Wash	Performance	User1	20
12	All Bars Perc AF1&2	Voice	Normal Pre1	98
13	Double Dip the Funk	Performance	User1	12
14	Dreamscape	Performance	User1	3
15	Abysse of the Sea	Performance	User1	16
16	Coastal	Performance	User1	18
17	Chillin Keys	Performance	User1	5
18	Hard Vintage	Voice	Normal Pre1	28
19	Green Oasis	Performance	User1	7
20	Head Full of Rock	Performance	User2	50
21	Nasty Dirty Funky	Performance	User1	116
22	Mega Steel	Voice	Normal Pre8	82
23	WoodWind Quartet	Voice	Normal Pre5	30
24	CrunchTime	Song	---	2
25	Andy Lucia	Performance	User1	8
26	Deep House 2	Performance	User2	62
27	SubwayTraxx Trigger	Performance	User1	121
28	Movie Horns	Voice	Normal Pre4	93
29	Semar Dub	Performance	User1	49
30	Semi Finale	Performance	User1	19
31	W Sweep	Performance	User2	78
32	Hot Sauce	Performance	User1	40
33	Chillin Mo	Performance	User2	33
34	Natural Wurli	Voice	Normal Pre1	45
35	On my Way to UK	Voice	Normal Pre7	105
36	Money on My Mind	Performance	User2	76
37	80's young gun	Performance	User2	116
38	Prec Amped AF1	Voice	Normal Pre3	27
39	Cello Duo AF1	Voice	Normal Pre4	6
40	Laser Beam	Song	---	3
41	Blues Spell	Performance	User2	118
42	Psychedelic Dream	Performance	User2	61
43	Electrode	Performance	User2	14
44	FullDraw/CVibrato	Voice	Normal Pre1	104
45	Austin City Blues	Performance	User1	118
46	Requiem	Performance	User1	51
47	Nuclear Fusion	Performance	User2	124
48	Casbian Nights	Performance	User1	50
49	Snow in Havana	Performance	User2	17
50	Full Tine	Voice	Normal Pre1	52
51	Simple Arp	Voice	Normal Pre8	8
52	Exit Inglewood	Performance	User2	82
53	Visual K++	Performance	User2	52
54	Crunched Up 376	Voice	Normal Pre2	111
55	Almighty	Voice	Normal Pre4	12
56	Someday	Pattern	---	1
57	Film Noir	Performance	User1	106
58	Crowded Place	Performance	User1	126
59	971 Nightflight	Performance	User2	112
60	Dynamic Brass AF1&2	Voice	Normal Pre4	97
61	Acid Club	Performance	User1	76
62	Trumpet Concert	Performance	User1	35
63	Flying Rhythm Bars	Voice	Normal Pre1	128
64	Canto de rua	Performance	User1	104

Master No.	Master Name	Mode	Bank Name	Program Number
65	Chilltronika	Performance	User1	1
66	CP 1979	Voice	Normal Pre1	19
67	Vowel Pad	Voice	Normal Pre6	27
68	Slow and Low	Performance	User1	15
69	Echo Park Rock	Performance	User1	86
70	Army Bass	Voice	Normal Pre3	117
71	Sweet Oboe Legato	Voice	Normal Pre5	21
72	Fractal T	Pattern	---	2
73	Let's Comp!	Performance	User1	74
74	Heart Breakz	Performance	User1	9
75	Latin House	Performance	User2	126
76	On Road AS1	Voice	Normal Pre1	91
77	Funkhunters	Performance	User2	10
78	Kogarashi	Performance	User1	39
79	Sample & Hold	Performance	User1	27
80	Multi-Cultural	Performance	User1	72
81	Jembrana	Performance	User1	43
82	Vintage'74	Voice	Normal Pre1	22
83	Dark Modulation Pad	Voice	Normal Pre5	117
84	Yah-Yo-Jah	Performance	User1	34
85	Arp Foundation	Performance	User2	48
86	Mute & Slide Vel	Voice	Normal Pre2	61
87	Violin Solo 2 AF1	Voice	Normal Pre4	2
88	Down Here	Pattern	---	3
89	Hold On a Minute	Performance	User1	38
90	Dancing Bars	Performance	User1	36
91	Electro Club	Performance	User1	14
92	Big Syn	Voice	Normal Pre4	117
93	Duck Groove	Performance	User1	90
94	Oboe Soloist	Performance	User1	83
95	turn the wheels...	Performance	User2	128
96	Balkan Blitz	Performance	User2	8
97	Gran Beat	Performance	User1	78
98	1968	Voice	Normal Pre1	18
99	Catching Wild Horses	Voice	Normal Pre6	59
100	Capital City	Performance	User2	34
101	Surfin' Kahuna	Performance	User2	38
102	VoodooMan	Voice	Normal Pre2	126
103	Velo Growl Legato	Voice	Normal Pre5	10
104	Compse UR Hit	Performance	User2	45
105	Blues Organ Trio	Performance	User1	42
106	Funfair	Performance	User1	57
107	Magic Spell	Performance	User1	113
108	Panther	Voice	Normal Pre1	119
109	Funky Finger	Performance	User1	28
110	Sprinkler	Performance	User1	80
111	Snow na Oto	Performance	User1	123
112	La Isla del Encanto	Performance	User2	56
113	Dream Shuffle	Performance	User1	122
114	Contempo	Voice	Normal Pre1	35
115	Pearls	Voice	Normal Pre6	37
116	West Coast Interact	Performance	User1	82
117	Patrol	Performance	User2	6
118	Moon Bass	Voice	Normal Pre3	57
119	Warm Big	Voice	Normal Pre4	45
120	Do U know I-o-v?	Performance	User2	77
121	All Guitars	Performance	User2	55
122	Maison Blanc	Performance	User1	100
123	ConcretePalaceAirmen	Performance	User2	20
124	Ob Soft	Voice	Normal Pre4	127
125	Jam For What?!	Performance	User2	117
126	Winds & Strings	Performance	User1	67
127	Kuroshio	Performance	User1	75
128	Bossa On the Beach	Performance	User2	40

Arpeggio Type List

General Voice types which are most suitable for the respective Arpeggio Types are listed in the "Voice Type" column. Among these, the ones in quotation marks are specific Voices actually provided on the MOX6/MOX8. Also, for Arpeggio Types belonging to the "Cntr" Category (pages 76 and 77), information about data (Control Change or Pitch Bend) programmed into the respective Arpeggio Types is listed in the "Voice Type" column. For Arpeggio Types programmed with Control Change data, the Control Change numbers are listed accordingly. For Arpeggio Types programmed with Pitch Bend data, Pitch Bend Range information is listed accordingly.

Main Category	Sub Category	ARP No.	ARP Name	Time Signature	Length	Original Tempo	Accent	Random SFX	Voice Type
ApKb	Rock	1	MA_70s Rock_ES	4/4	2	130			Acoustic Piano
ApKb	Rock	2	MB_70s Rock_ES	4/4	1	130			:
ApKb	Rock	3	MC_70s Rock	4/4	2	130			:
ApKb	Rock	4	MD_70s Rock	4/4	4	130			:
ApKb	Rock	5	FA_70s Rock	4/4	1	130			:
ApKb	Rock	6	FB_70s Rock_ES	4/4	1	130			:
ApKb	Rock	7	FC_70s Rock_ES	4/4	2	130			:
ApKb	Rock	8	MA_Rockn Pt	4/4	4	130			:
ApKb	Rock	9	MA_Rock & Roll_XS	4/4	4	172			:
ApKb	Rock	10	MB_Rock & Roll_XS	4/4	4	172			:
ApKb	Rock	11	MC_Rock & Roll_XS	4/4	4	172			:
ApKb	Rock	12	FA_Rock & Roll_XS	4/4	1	172			:
ApKb	Rock	13	FB_Rock & Roll_XS	4/4	1	172			:
ApKb	Rock	14	FC_Rock & Roll_XS	4/4	1	172			:
ApKb	Rock	15	BA_Rock & Roll_XS	4/4	1	172			:
ApKb	Rock	16	MA_Unplugged 1_XS	4/4	4	120			:
ApKb	Rock	17	MB_Unplugged 1_XS	4/4	4	120			:
ApKb	Rock	18	MC_Unplugged 1_XS	4/4	4	120			:
ApKb	Rock	19	FA_Unplugged 1_XS	4/4	1	120			:
ApKb	Rock	20	FB_Unplugged 1_XS	4/4	1	120			:
ApKb	Rock	21	FC_Unplugged 1_XS	4/4	1	120			:
ApKb	Rock	22	BA_Unplugged 1_XS	4/4	1	120			:
ApKb	Rock	23	MA_Unplugged 3_XS	4/4	4	113			:
ApKb	Rock	24	MB_Unplugged 3_XS	4/4	4	113			:
ApKb	Rock	25	MC_Unplugged 3_XS	4/4	4	113			:
ApKb	Rock	26	FA_Unplugged 3_XS	4/4	1	113			:
ApKb	Rock	27	FB_Unplugged 3_XS	4/4	1	113			:
ApKb	Rock	28	FC_Unplugged 3_XS	4/4	1	113			:
ApKb	Rock	29	BA_Unplugged 3_XS	4/4	1	113			:
ApKb	Rock	30	MA_Unplugged 3_ES	4/4	4	113			:
ApKb	Rock	31	MB_Unplugged 3_ES	4/4	4	113			:
ApKb	Rock	32	MC_Unplugged 3_ES	4/4	4	113			:
ApKb	Rock	33	FA_Unplugged 3_ES	4/4	1	113			:
ApKb	Rock	34	FB_Unplugged 3_ES	4/4	1	113			:
ApKb	Rock	35	FC_Unplugged 3_ES	4/4	1	113			:
ApKb	Rock	36	BA_Unplugged 3_ES	4/4	1	113			:
ApKb	Rock	37	MA_EP Ballad_XS	4/4	2	60			Electric Piano
ApKb	Rock	38	MB_EP Ballad_XS	4/4	2	60			:
ApKb	Rock	39	MC_EP Ballad_XS	4/4	2	60			:
ApKb	Rock	40	FA_EP Ballad_XS	4/4	1	60			:
ApKb	Rock	41	FB_EP Ballad_XS	4/4	1	60			:
ApKb	Rock	42	FC_EP Ballad_XS	4/4	1	60			:
ApKb	Rock	43	BA_EP Ballad_XS	4/4	1	60			:
ApKb	Rock	44	MA_Cool 8Beat_XS	4/4	2	100			:
ApKb	Rock	45	MB_Cool 8Beat_XS	4/4	2	100			:
ApKb	Rock	46	MC_Cool 8Beat_XS	4/4	2	100			:
ApKb	Rock	47	FA_Cool 8Beat_XS	4/4	1	100			:
ApKb	Rock	48	FB_Cool 8Beat_XS	4/4	1	100			:
ApKb	Rock	49	FC_Cool 8Beat_XS	4/4	1	100			:
ApKb	Rock	50	BA_Cool 8Beat_XS	4/4	1	100			:
ApKb	Rock	51	MA_8Beat Basic_XS	4/4	4	120			:
ApKb	Rock	52	MB_8Beat Basic_XS	4/4	4	120			:
ApKb	Rock	53	MC_8Beat Basic_XS	4/4	4	120			:
ApKb	Rock	54	FA_8Beat Basic_XS	4/4	1	120			:
ApKb	Rock	55	FB_8Beat Basic_XS	4/4	1	120			:
ApKb	Rock	56	FC_8Beat Basic_XS	4/4	1	120			:
ApKb	Rock	57	BA_8Beat Basic_XS	4/4	1	120			:
ApKb	Rock	58	MA_8Beat Basic_ES	4/4	4	120			:
ApKb	Rock	59	MB_8Beat Basic_ES	4/4	4	120			:
ApKb	Rock	60	MC_8Beat Basic_ES	4/4	4	120			:
ApKb	Rock	61	FA_8Beat Basic_ES	4/4	1	120			:
ApKb	Rock	62	FB_8Beat Basic_ES	4/4	1	120			:
ApKb	Rock	63	FC_8Beat Basic_ES	4/4	1	120			:
ApKb	Rock	64	BA_8Beat Basic_ES	4/4	1	120			:
ApKb	Rock	65	MA1_8Beat Slow_XS	4/4	4	78			Acoustic Piano
ApKb	Rock	66	MB1_8Beat Slow_XS	4/4	4	78			:
ApKb	Rock	67	MC1_8Beat Slow_XS	4/4	4	78			:
ApKb	Rock	68	FA1_8Beat Slow_XS	4/4	1	78			:
ApKb	Rock	69	FB1_8Beat Slow_XS	4/4	1	78			:
ApKb	Rock	70	FC1_8Beat Slow_XS	4/4	1	78			:
ApKb	Rock	71	BA1_8Beat Slow_XS	4/4	1	78			:
ApKb	Rock	72	MA1_8Beat Slow_ES	4/4	4	78			:
ApKb	Rock	73	MB1_8Beat Slow_ES	4/4	4	78			:
ApKb	Rock	74	MC1_8Beat Slow_ES	4/4	4	78			:
ApKb	Rock	75	FA1_8Beat Slow_ES	4/4	1	78			:
ApKb	Rock	76	FB1_8Beat Slow_ES	4/4	1	78			:
ApKb	Rock	77	FC1_8Beat Slow_ES	4/4	1	78			:
ApKb	Rock	78	BA1_8Beat Slow_ES	4/4	1	78			:
ApKb	Rock	79	MA2_8Beat Slow_XS	4/4	4	78			Electric Piano
ApKb	Rock	80	MB2_8Beat Slow_XS	4/4	4	78			:

Main Category	Sub Category	ARP No.	ARP Name	Time Signature	Length	Original Tempo	Accent	Random SFX	Voice Type
ApKb	Rock	81	MC2_8Beat Slow_XS	4/4	4	78			Electric Piano
ApKb	Rock	82	FA2_8Beat Slow_XS	4/4	1	78			:
ApKb	Rock	83	FB2_8Beat Slow_XS	4/4	1	78			:
ApKb	Rock	84	FC2_8Beat Slow_XS	4/4	1	78			:
ApKb	Rock	85	BA2_8Beat Slow_XS	4/4	1	78			:
ApKb	Rock	86	MA2_8Beat Slow_ES	4/4	4	78			:
ApKb	Rock	87	MB2_8Beat Slow_ES	4/4	4	78			:
ApKb	Rock	88	MC2_8Beat Slow_ES	4/4	4	78			:
ApKb	Rock	89	FA2_8Beat Slow_ES	4/4	1	78			:
ApKb	Rock	90	FB2_8Beat Slow_ES	4/4	1	78			:
ApKb	Rock	91	FC2_8Beat Slow_ES	4/4	1	78			:
ApKb	Rock	92	BA2_8Beat Slow_ES	4/4	1	78			:
ApKb	Rock	93	MA_8Beat Soft_XS	4/4	4	100			:
ApKb	Rock	94	MB_8Beat Soft_XS	4/4	4	100			:
ApKb	Rock	95	MC_8Beat Soft_XS	4/4	4	100			:
ApKb	Rock	96	FA_8Beat Soft_XS	4/4	1	100			:
ApKb	Rock	97	FB_8Beat Soft_XS	4/4	1	100			:
ApKb	Rock	98	FC_8Beat Soft_XS	4/4	1	100			:
ApKb	Rock	99	BA_8Beat Soft_XS	4/4	1	100			:
ApKb	Rock	100	MA_8Beat Soft_ES	4/4	4	100			:
ApKb	Rock	101	MB_8Beat Soft_ES	4/4	4	100			:
ApKb	Rock	102	MC_8Beat Soft_ES	4/4	4	100			:
ApKb	Rock	103	FA_8Beat Soft_ES	4/4	1	100			:
ApKb	Rock	104	FB_8Beat Soft_ES	4/4	1	100			:
ApKb	Rock	105	FC_8Beat Soft_ES	4/4	1	100			:
ApKb	Rock	106	BA_8Beat Soft_ES	4/4	1	100			:
ApKb	Rock	107	MA_Slowfeel	4/4	1	74			:
ApKb	Rock	108	MB_Slowfeel	4/4	1	74			:
ApKb	Rock	109	MC_Slowfeel	4/4	1	74			:
ApKb	Rock	110	MA_Slowfeel	4/4	1	74			:
ApKb	Rock	111	FB_Slowfeel	4/4	1	74			:
ApKb	Rock	112	FC_Slowfeel	4/4	1	74			:
ApKb	Rock	113	MA_16Bt Ballad1_XS	4/4	4	75			:
ApKb	Rock	114	MB_16Bt Ballad1_XS	4/4	4	75			:
ApKb	Rock	115	MC_16Bt Ballad1_XS	4/4	4	75			:
ApKb	Rock	116	FA_16Bt Ballad1_XS	4/4	1	75			:
ApKb	Rock	117	FB_16Bt Ballad1_XS	4/4	1	75			:
ApKb	Rock	118	FC_16Bt Ballad1_XS	4/4	1	75			:
ApKb	Rock	119	BA_16Bt Ballad1_XS	4/4	1	75			:
ApKb	Rock	120	MA_16Bt Ballad1_ES	4/4	4	75			:
ApKb	Rock	121	MB_16Bt Ballad1_ES	4/4	4	75			:
ApKb	Rock	122	MC_16Bt Ballad1_ES	4/4	4	75			:
ApKb	Rock	123	FA_16Bt Ballad1_ES	4/4	1	75			:
ApKb	Rock	124	FB_16Bt Ballad1_ES	4/4	1	75			:
ApKb	Rock	125	FC_16Bt Ballad1_ES	4/4	1	75			:
ApKb	Rock	126	BA_16Bt Ballad1_ES	4/4	1	75			:
ApKb	Rock	127	MA_16BeatBasic1_XS	4/4	4	90			:
ApKb	Rock	128	MB_16BeatBasic1_XS	4/4	4	90			:
ApKb	Rock	129	MC_16BeatBasic1_XS	4/4	4	90			:
ApKb	Rock	130	FA_16BeatBasic1_XS	4/4	1	90			:
ApKb	Rock	131	FB_16BeatBasic1_XS	4/4	1	90			:
ApKb	Rock	132	FC_16BeatBasic1_XS	4/4	1	90			:
ApKb	Rock	133	BA_16BeatBasic1_XS	4/4	1	90			:
ApKb	Rock	134	MA_16BeatBasic1_ES	4/4	4	90			:
ApKb	Rock	135	MB_16BeatBasic1_ES	4/4	4	90			:
ApKb	Rock	136	MC_16BeatBasic1_ES	4/4	4	90			:
ApKb	Rock	137	FA_16BeatBasic1_ES	4/4	1	90			:
ApKb	Rock	138	FB_16BeatBasic1_ES	4/4	1	90			:
ApKb	Rock	139	FC_16BeatBasic1_ES	4/4	1	90			:
ApKb	Rock	140	BA_16BeatBasic1_ES	4/4	1	90			:
ApKb	Rock	141	MA_16BeatBasic2_XS	4/4	4	77			:
ApKb	Rock	142	MB_16BeatBasic2_XS	4/4	4	77			:
ApKb	Rock	143	MC_16BeatBasic2_XS	4/4	4	77			:
ApKb	Rock	144	FA_16BeatBasic2_XS	4/4	1	77			:
ApKb	Rock	145	FB_16BeatBasic2_XS	4/4	1	77			:
ApKb	Rock	146	FC_16BeatBasic2_XS	4/4	1	77			:
ApKb	Rock	147	BA_16BeatBasic2_XS	4/4	1	77			:
ApKb	Rock	148	MA_16BeatBasic2_ES	4/4	4	77			:
ApKb	Rock	149	MB_16BeatBasic2_ES	4/4	4	77			:
ApKb	Rock	150	MC_16BeatBasic2_ES	4/4	4	77			:
ApKb	Rock	151	FA_16BeatBasic2_ES	4/4	1	77			:
ApKb	Rock	152	FB_16BeatBasic2_ES	4/4	1	77			:
ApKb	Rock	153	FC_16BeatBasic2_ES	4/4	1	77			:
ApKb	Rock	154	BA_16BeatBasic2_ES	4/4	1	77			:
ApKb	Rock	155	MA_16Beat Pop 1_XS	4/4	4	103			:
ApKb	Rock	156	MB_16Beat Pop 1_XS	4/4	4	103			:
ApKb	Rock	157	MC_16Beat Pop 1_XS	4/4	4	103			:
ApKb	Rock	158	FA_16Beat Pop 1_XS	4/4	1	103			:
ApKb	Rock	159	FB_16Beat Pop 1_XS	4/4	1	103			:
ApKb	Rock	160	FC_16Beat Pop 1_XS	4/4	1	103			:

Arpeggio Type List

Main Category	Sub Category	ARP No.	ARP Name	Time Signature	Length	Original Tempo	Accent	Random SFX	Voice Type
ApKb	Rock	161	BA_16Beat Pop 1_XS	4/4	1	103			Electric Piano
ApKb	Rock	162	MA_16Beat Pop 1_ES	4/4	4	103			:
ApKb	Rock	163	MB_16Beat Pop 1_ES	4/4	4	103			:
ApKb	Rock	164	MC_16Beat Pop 1_ES	4/4	4	103			:
ApKb	Rock	165	FA_16Beat Pop 1_ES	4/4	1	103			:
ApKb	Rock	166	FB_16Beat Pop 1_ES	4/4	1	103			:
ApKb	Rock	167	FC_16Beat Pop 1_ES	4/4	1	103			:
ApKb	Rock	168	BA_16Beat Pop 1_ES	4/4	1	103			:
ApKb	Rock	169	MA_16Beat Pop 2_XS	4/4	4	94			Acoustic Piano
ApKb	Rock	170	MB_16Beat Pop 2_XS	4/4	4	94			:
ApKb	Rock	171	MC_16Beat Pop 2_XS	4/4	4	94			:
ApKb	Rock	172	FA_16Beat Pop 2_XS	4/4	1	94			:
ApKb	Rock	173	FB_16Beat Pop 2_XS	4/4	1	94			:
ApKb	Rock	174	FC_16Beat Pop 2_XS	4/4	1	94			:
ApKb	Rock	175	BA_16Beat Pop 2_XS	4/4	1	94			:
ApKb	Rock	176	MA_16Beat Pop 2_ES	4/4	4	94			:
ApKb	Rock	177	MB_16Beat Pop 2_ES	4/4	4	94			:
ApKb	Rock	178	MC_16Beat Pop 2_ES	4/4	4	94			:
ApKb	Rock	179	FA_16Beat Pop 2_ES	4/4	1	94			:
ApKb	Rock	180	FB_16Beat Pop 2_ES	4/4	1	94			:
ApKb	Rock	181	FC_16Beat Pop 2_ES	4/4	1	94			:
ApKb	Rock	182	BA_16Beat Pop 2_ES	4/4	1	94			:
ApKb	Rock	183	MC1_Piano Club	4/4	1	96			:
ApKb	Rock	184	MD1_Piano Club	4/4	1	96			:
ApKb	Rock	185	IA1_Piano Club	4/4	1	96			:
ApKb	Rock	186	MD2_Piano Club	4/4	2	96			:
ApKb	Rock	187	IA2_Piano Club	4/4	2	96			:
ApKb	Rock	188	MC3_Piano Club	4/4	2	96			:
ApKb	Rock	189	IA3_Piano Club	4/4	2	96			:
ApKb	Rock	190	MB1_Analog Pop	4/4	2	93			Electric Piano
ApKb	Rock	191	MC2_Analog Pop	4/4	2	93			:
ApKb	Rock	192	IA2_Analog Pop	4/4	1	93			:
ApKb	Rock	193	MA_6/8 Pop_XS	4/4	4	100			:
ApKb	Rock	194	MB_6/8 Pop_XS	4/4	4	100			:
ApKb	Rock	195	MC_6/8 Pop_XS	4/4	4	100			:
ApKb	Rock	196	FA_6/8 Pop_XS	4/4	1	100			:
ApKb	Rock	197	FB_6/8 Pop_XS	4/4	1	100			:
ApKb	Rock	198	FC_6/8 Pop_XS	4/4	1	100			:
ApKb	Rock	199	BA_6/8 Pop_XS	4/4	1	100			:
ApKb	Rock	200	MA_6/8 Pop_ES	4/4	4	100			:
ApKb	Rock	201	MB_6/8 Pop_ES	4/4	4	100			:
ApKb	Rock	202	MC_6/8 Pop_ES	4/4	4	100			:
ApKb	Rock	203	FA_6/8 Pop_ES	4/4	1	100			:
ApKb	Rock	204	FB_6/8 Pop_ES	4/4	1	100			:
ApKb	Rock	205	FC_6/8 Pop_ES	4/4	1	100			:
ApKb	Rock	206	BA_6/8 Pop_ES	4/4	1	100			:
ApKb	Rock	207	MA_ProgresRock2_XS	4/4	4	120			:
ApKb	Rock	208	MB_ProgresRock2_XS	4/4	4	120			:
ApKb	Rock	209	MC_ProgresRock2_XS	4/4	4	120			:
ApKb	Rock	210	FA_ProgresRock2_XS	4/4	1	120			:
ApKb	Rock	211	FB_ProgresRock2_XS	4/4	1	120			:
ApKb	Rock	212	FC_ProgresRock2_XS	4/4	1	120			:
ApKb	Rock	213	BA_ProgresRock2_XS	4/4	1	120			:
ApKb	Rock	214	MA_ProgresRock2_ES	4/4	4	120			:
ApKb	Rock	215	MB_ProgresRock2_ES	4/4	4	120			:
ApKb	Rock	216	MC_ProgresRock2_ES	4/4	4	120			:
ApKb	Rock	217	FA_ProgresRock2_ES	4/4	1	120			:
ApKb	Rock	218	FB_ProgresRock2_ES	4/4	1	120			:
ApKb	Rock	219	FC_ProgresRock2_ES	4/4	1	120			:
ApKb	Rock	220	BA_ProgresRock2_ES	4/4	1	120			:
ApKb	R&B	221	MA_Funk 1_XS	4/4	8	104			:
ApKb	R&B	222	MB_Funk 1_XS	4/4	8	104			:
ApKb	R&B	223	MC_Funk 1_XS	4/4	8	104			:
ApKb	R&B	224	FA_Funk 1_XS	4/4	1	104			:
ApKb	R&B	225	FB_Funk 1_XS	4/4	1	104			:
ApKb	R&B	226	FC_Funk 1_XS	4/4	1	104			:
ApKb	R&B	227	BA_Funk 1_XS	4/4	1	104			:
ApKb	R&B	228	MD_Cool Funk	4/4	2	96			:
ApKb	R&B	229	IA_Cool Funk	4/4	2	96			:
ApKb	R&B	230	FA_Cool Funk	4/4	1	96			:
ApKb	R&B	231	FB_Cool Funk	4/4	1	96			:
ApKb	R&B	232	MA_Jazz Pop_XS	4/4	2	102			:
ApKb	R&B	233	MB_Jazz Pop_XS	4/4	2	102			:
ApKb	R&B	234	MC_Jazz Pop_XS	4/4	2	102			:
ApKb	R&B	235	FA_Jazz Pop_XS	4/4	1	102			:
ApKb	R&B	236	FB_Jazz Pop_XS	4/4	1	102			:
ApKb	R&B	237	FC_Jazz Pop_XS	4/4	1	102			:
ApKb	R&B	238	BA_Jazz Pop_XS	4/4	1	102			:
ApKb	R&B	239	MA_Slow & Easy_XS	4/4	4	72			:
ApKb	R&B	240	MB_Slow & Easy_XS	4/4	4	72			:
ApKb	R&B	241	MC_Slow & Easy_XS	4/4	4	72			:
ApKb	R&B	242	FA_Slow & Easy_XS	4/4	1	72			:
ApKb	R&B	243	FB_Slow & Easy_XS	4/4	1	72			:

Main Category	Sub Category	ARP No.	ARP Name	Time Signature	Length	Original Tempo	Accent	Random SFX	Voice Type
ApKb	R&B	244	FC_Slow & Easy_XS	4/4	1	72			Electric Piano
ApKb	R&B	245	BA_Slow & Easy_XS	4/4	1	72			:
ApKb	R&B	246	MA_Club Jazz 1_XS	4/4	4	125			Acoustic Piano
ApKb	R&B	247	MB_Club Jazz 1_XS	4/4	4	125			:
ApKb	R&B	248	MC_Club Jazz 1_XS	4/4	4	125			:
ApKb	R&B	249	FA_Club Jazz 1_XS	4/4	1	125			:
ApKb	R&B	250	FB_Club Jazz 1_XS	4/4	1	125			:
ApKb	R&B	251	FC_Club Jazz 1_XS	4/4	1	125			:
ApKb	R&B	252	BA_Club Jazz 1_XS	4/4	1	125			:
ApKb	R&B	253	MA_Club Jazz 1_ES	4/4	4	125			:
ApKb	R&B	254	MB_Club Jazz 1_ES	4/4	4	125			:
ApKb	R&B	255	MC_Club Jazz 1_ES	4/4	4	125			:
ApKb	R&B	256	FA_Club Jazz 1_ES	4/4	1	125			:
ApKb	R&B	257	FB_Club Jazz 1_ES	4/4	1	125			:
ApKb	R&B	258	FC_Club Jazz 1_ES	4/4	1	125			:
ApKb	R&B	259	BA_Club Jazz 1_ES	4/4	1	125			:
ApKb	R&B	260	MA_Club Jazz 2_XS	4/4	4	92			:
ApKb	R&B	261	MB_Club Jazz 2_XS	4/4	4	92			:
ApKb	R&B	262	MC_Club Jazz 2_XS	4/4	4	92			:
ApKb	R&B	263	FA_Club Jazz 2_XS	4/4	1	92			:
ApKb	R&B	264	FB_Club Jazz 2_XS	4/4	1	92			:
ApKb	R&B	265	FC_Club Jazz 2_XS	4/4	1	92			:
ApKb	R&B	266	BA_Club Jazz 2_XS	4/4	1	92			:
ApKb	R&B	267	MA_Club Jazz 2_ES	4/4	4	92			:
ApKb	R&B	268	MB_Club Jazz 2_ES	4/4	4	92			:
ApKb	R&B	269	MC_Club Jazz 2_ES	4/4	4	92			:
ApKb	R&B	270	FA_Club Jazz 2_ES	4/4	1	92			:
ApKb	R&B	271	FB_Club Jazz 2_ES	4/4	1	92			:
ApKb	R&B	272	FC_Club Jazz 2_ES	4/4	1	92			:
ApKb	R&B	273	BA_Club Jazz 2_ES	4/4	1	92			:
ApKb	R&B	274	MA_Pop Shuffle1_XS	4/4	4	94			:
ApKb	R&B	275	MB_Pop Shuffle1_XS	4/4	4	94			:
ApKb	R&B	276	MC_Pop Shuffle1_XS	4/4	4	94			:
ApKb	R&B	277	FA_Pop Shuffle1_XS	4/4	1	94			:
ApKb	R&B	278	FB_Pop Shuffle1_XS	4/4	1	94			:
ApKb	R&B	279	FC_Pop Shuffle1_XS	4/4	1	94			:
ApKb	R&B	280	BA_Pop Shuffle1_XS	4/4	1	94			:
ApKb	R&B	281	MA_Pop Shuffle1_ES	4/4	4	94			:
ApKb	R&B	282	MB_Pop Shuffle1_ES	4/4	4	94			:
ApKb	R&B	283	MC_Pop Shuffle1_ES	4/4	4	94			:
ApKb	R&B	284	FA_Pop Shuffle1_ES	4/4	1	94			:
ApKb	R&B	285	FB_Pop Shuffle1_ES	4/4	1	94			:
ApKb	R&B	286	FC_Pop Shuffle1_ES	4/4	1	94			:
ApKb	R&B	287	BA_Pop Shuffle1_ES	4/4	1	94			:
ApKb	R&B	288	MA_Pop Shuffle2_XS	4/4	4	80			:
ApKb	R&B	289	MB_Pop Shuffle2_XS	4/4	4	80			:
ApKb	R&B	290	MC_Pop Shuffle2_XS	4/4	4	80			:
ApKb	R&B	291	FA_Pop Shuffle2_XS	4/4	1	80			:
ApKb	R&B	292	FB_Pop Shuffle2_XS	4/4	1	80			:
ApKb	R&B	293	FC_Pop Shuffle2_XS	4/4	1	80			:
ApKb	R&B	294	BA_Pop Shuffle2_XS	4/4	1	80			:
ApKb	R&B	295	MA_Pop Shuffle2_ES	4/4	4	80			:
ApKb	R&B	296	MB_Pop Shuffle2_ES	4/4	4	80			:
ApKb	R&B	297	MC_Pop Shuffle2_ES	4/4	4	80			:
ApKb	R&B	298	FA_Pop Shuffle2_ES	4/4	1	80			:
ApKb	R&B	299	FB_Pop Shuffle2_ES	4/4	1	80			:
ApKb	R&B	300	FC_Pop Shuffle2_ES	4/4	1	80			:
ApKb	R&B	301	BA_Pop Shuffle2_ES	4/4	1	80			:
ApKb	R&B	302	MA_Gospel Funk_XS	4/4	4	106			:
ApKb	R&B	303	MB_Gospel Funk_XS	4/4	4	106			:
ApKb	R&B	304	MC_Gospel Funk_XS	4/4	4	106			:
ApKb	R&B	305	FA_Gospel Funk_XS	4/4	1	106			:
ApKb	R&B	306	FB_Gospel Funk_XS	4/4	1	106			:
ApKb	R&B	307	FC_Gospel Funk_XS	4/4	1	106			:
ApKb	R&B	308	BA_Gospel Funk_XS	4/4	1	106			:
ApKb	R&B	309	MA_Funk Disco_XS	4/4	2	126			Electric Piano
ApKb	R&B	310	MB_Funk Disco_XS	4/4	2	126			:
ApKb	R&B	311	MC_Funk Disco_XS	4/4	2	126			:
ApKb	R&B	312	FA_Funk Disco_XS	4/4	1	126			:
ApKb	R&B	313	FB_Funk Disco_XS	4/4	1	126			:
ApKb	R&B	314	FC_Funk Disco_XS	4/4	1	126			:
ApKb	R&B	315	BA_Funk Disco_XS	4/4	1	126			:
ApKb	R&B	316	MA_70sDiscoFunk_XS	4/4	4	112			Acoustic Piano
ApKb	R&B	317	MB_70sDiscoFunk_XS	4/4	4	112			:
ApKb	R&B	318	MC_70sDiscoFunk_XS	4/4	4	112			:
ApKb	R&B	319	FA_70sDiscoFunk_XS	4/4	1	112			:
ApKb	R&B	320	FB_70sDiscoFunk_XS	4/4	1	112			:
ApKb	R&B	321	FC_70sDiscoFunk_XS	4/4	1	112			:
ApKb	R&B	322	BA_70sDiscoFunk_XS	4/4	1	112			:
ApKb	R&B	323	MA_Philadelphia_XS	4/4	2	100			

Arpeggio Type List

Main Category	Sub Category	ARP No.	ARP Name	Time Signature	Length	Original Tempo	Accent	Random SFX	Voice Type
ApKb	R&B	327	FB_Philadelphia_XS	4/4	1	100			Acoustic Piano
ApKb	R&B	328	FC_Philadelphia_XS	4/4	1	100			:
ApKb	R&B	329	BA_Philadelphia_XS	4/4	1	100			:
ApKb	R&B	330	MA_R&B Disco	4/4	2	110			Electric Piano
ApKb	R&B	331	MD_R&B Disco	4/4	2	110			:
ApKb	R&B	332	FB_R&B Disco	4/4	1	110			:
ApKb	R&B	333	FC_R&B Disco	4/4	2	110			:
ApKb	R&B	334	MA_ChartPop1_XS	4/4	4	92			:
ApKb	R&B	335	MB_ChartPop1_XS	4/4	4	92			:
ApKb	R&B	336	MC_ChartPop1_XS	4/4	4	92			:
ApKb	R&B	337	FA_ChartPop1_XS	4/4	1	92			:
ApKb	R&B	338	FB_ChartPop1_XS	4/4	1	92			:
ApKb	R&B	339	FC_ChartPop1_XS	4/4	1	92			:
ApKb	R&B	340	BA_ChartPop1_XS	4/4	1	92			:
ApKb	R&B	341	MA_H-R&B Pop_XS	4/4	4	140			:
ApKb	R&B	342	MB_H-R&B Pop_XS	4/4	4	140			:
ApKb	R&B	343	MC_H-R&B Pop_XS	4/4	4	140			:
ApKb	R&B	344	FA_H-R&B Pop_XS	4/4	1	140			:
ApKb	R&B	345	FB_H-R&B Pop_XS	4/4	1	140			:
ApKb	R&B	346	FC_H-R&B Pop_XS	4/4	1	140			:
ApKb	R&B	347	BA_H-R&B Pop_XS	4/4	1	140			:
ApKb	R&B	348	MA_J-R&B Pop_XS	4/4	4	100			:
ApKb	R&B	349	MB_J-R&B Pop_XS	4/4	4	100			:
ApKb	R&B	350	MC_J-R&B Pop_XS	4/4	4	100			:
ApKb	R&B	351	FA_J-R&B Pop_XS	4/4	1	100			:
ApKb	R&B	352	FB_J-R&B Pop_XS	4/4	1	100			:
ApKb	R&B	353	FC_J-R&B Pop_XS	4/4	1	100			:
ApKb	R&B	354	MA_R&B Ballad 1_XS	4/4	4	70			:
ApKb	R&B	355	MB_R&B Ballad 1_XS	4/4	4	70			:
ApKb	R&B	356	MC_R&B Ballad 1_XS	4/4	4	70			:
ApKb	R&B	357	FA_R&B Ballad 1_XS	4/4	1	70			:
ApKb	R&B	358	FB_R&B Ballad 1_XS	4/4	1	70			:
ApKb	R&B	359	FC_R&B Ballad 1_XS	4/4	1	70			:
ApKb	R&B	360	BA_R&B Ballad 1_XS	4/4	1	70			:
ApKb	R&B	361	MA_R&B Ballad 3_XS	4/4	4	113			:
ApKb	R&B	362	MB_R&B Ballad 3_XS	4/4	4	113			:
ApKb	R&B	363	MC_R&B Ballad 3_XS	4/4	4	113			:
ApKb	R&B	364	FA_R&B Ballad 3_XS	4/4	1	113			:
ApKb	R&B	365	FB_R&B Ballad 3_XS	4/4	1	113			:
ApKb	R&B	366	FC_R&B Ballad 3_XS	4/4	1	113			:
ApKb	R&B	367	MA_Ballad EP1	4/4	2	74			:
ApKb	R&B	368	MA_Ballad EP2	4/4	2	74			:
ApKb	R&B	369	MA_Ballad EP3	4/4	2	74			:
ApKb	R&B	370	MA_Swing EP	4/4	1	101			:
ApKb	R&B	371	MA_EP Chords	4/4	2	101			:
ApKb	R&B	372	MA1_6/8 R&B	4/4	2	61			Acoustic Piano
ApKb	R&B	373	MB1_6/8 R&B	4/4	2	61			:
ApKb	R&B	374	MC1_6/8 R&B	4/4	2	61			:
ApKb	R&B	375	MD1_6/8 R&B	4/4	2	61			:
ApKb	R&B	376	IA1_6/8 R&B	4/4	2	61			:
ApKb	R&B	377	FA1_6/8 R&B	4/4	1	61			:
ApKb	R&B	378	FB1_6/8 R&B	4/4	1	61			:
ApKb	R&B	379	MA2_6/8 R&B	4/4	2	61			Electric Piano
ApKb	R&B	380	MB2_6/8 R&B	4/4	2	61			:
ApKb	R&B	381	MC2_6/8 R&B	4/4	2	61			:
ApKb	R&B	382	MD2_6/8 R&B	4/4	2	61			:
ApKb	R&B	383	IA2_6/8 R&B	4/4	2	61			:
ApKb	R&B	384	FA2_6/8 R&B_ES	4/4	1	61			:
ApKb	R&B	385	FB2_6/8 R&B_ES	4/4	1	61			:
ApKb	R&B	386	MB_Smooth 1	4/4	2	115			:
ApKb	R&B	387	MC_Smooth 1	4/4	2	115			:
ApKb	R&B	388	MA_Bklyn	4/4	2	89			Acoustic Piano
ApKb	R&B	389	MB_Bklyn	4/4	2	89			:
ApKb	R&B	390	MC_Bklyn_ES	4/4	2	89			:
ApKb	R&B	391	MD_Bklyn	4/4	2	89			:
ApKb	R&B	392	ME_Bklyn_ES	4/4	2	89			:
ApKb	R&B	393	MA_HipHopEpic	4/4	2	85			:
ApKb	R&B	394	MB_HipHopEpic_ES	4/4	2	85			:
ApKb	R&B	395	MA_New Hip Hop_XS	4/4	2	85			Electric Piano
ApKb	R&B	396	MB_New Hip Hop_XS	4/4	2	85			:
ApKb	R&B	397	MC_New Hip Hop_XS	4/4	2	85			:
ApKb	R&B	398	FA_New Hip Hop_XS	4/4	1	85			:
ApKb	R&B	399	FB_New Hip Hop_XS	4/4	1	85			:
ApKb	R&B	400	FC_New Hip Hop_XS	4/4	1	85			:
ApKb	R&B	401	BA_New Hip Hop_XS	4/4	1	85			:
ApKb	R&B	402	MA1_Hip Hop 1_ES	4/4	2	105			:
ApKb	R&B	403	MB1_Hip Hop 1_ES	4/4	2	105			:
ApKb	R&B	404	MC1_Hip Hop 1_ES	4/4	2	105			:
ApKb	R&B	405	FB1_Hip Hop 1_ES	4/4	1	105			:
ApKb	R&B	406	MA2_Hip Hop 1_ES	4/4	2	105			Clavi
ApKb	R&B	407	MB2_Hip Hop 1_ES	4/4	2	105			:
ApKb	R&B	408	MC2_Hip Hop 1_ES	4/4	2	105			:
ApKb	R&B	409	FB2_Hip Hop 1_ES	4/4	1	105			:

Main Category	Sub Category	ARP No.	ARP Name	Time Signature	Length	Original Tempo	Accent	Random SFX	Voice Type
ApKb	R&B	410	FC_Hip Hop 2	4/4	2	94			Electric Piano
ApKb	R&B	411	MA_Hip Reggae_XS	4/4	4	92			Acoustic Piano
ApKb	R&B	412	MB_Hip Reggae_XS	4/4	4	92			:
ApKb	R&B	413	MC_Hip Reggae_XS	4/4	4	92			:
ApKb	R&B	414	FB_Hip Reggae_XS	4/4	1	92			:
ApKb	R&B	415	MA1_ClasichipHop	4/4	1	90			:
ApKb	R&B	416	MB1_ClasichipHop	4/4	1	90			:
ApKb	R&B	417	IA2_ClasichipHop_ES	4/4	2	90			Electric Piano
ApKb	R&B	418	MA_Soul 2_ES	4/4	2	120			Acoustic Piano
ApKb	R&B	419	MB_Soul 2_ES	4/4	1	120			:
ApKb	R&B	420	MC_Soul 2_ES	4/4	4	120			:
ApKb	R&B	421	MD_Soul 2_ES	4/4	4	120			:
ApKb	R&B	422	FC_Soul 2_ES	4/4	4	120			:
ApKb	R&B	423	MA_Frankly Soul_XS	4/4	4	120			:
ApKb	R&B	424	MB_Frankly Soul_XS	4/4	4	120			:
ApKb	R&B	425	MC_Frankly Soul_XS	4/4	4	120			:
ApKb	R&B	426	FA_Frankly Soul_XS	4/4	1	120			:
ApKb	R&B	427	FB_Frankly Soul_XS	4/4	1	120			:
ApKb	R&B	428	FC_Frankly Soul_XS	4/4	1	120			:
ApKb	R&B	429	BA_Frankly Soul_XS	4/4	1	120			:
ApKb	R&B	430	MA_Soul Beat_XS	4/4	4	124			:
ApKb	R&B	431	MB_Soul Beat_XS	4/4	4	124			:
ApKb	R&B	432	MC_Soul Beat_XS	4/4	4	124			:
ApKb	R&B	433	FA_Soul Beat_XS	4/4	1	124			:
ApKb	R&B	434	FB_Soul Beat_XS	4/4	1	124			:
ApKb	R&B	435	FC_Soul Beat_XS	4/4	1	124			:
ApKb	R&B	436	BA_Soul Beat_XS	4/4	1	124			:
ApKb	R&B	437	MA_Soul Shuffle_XS	4/4	4	98			Electric Piano
ApKb	R&B	438	MB_Soul Shuffle_XS	4/4	4	98			:
ApKb	R&B	439	MC_Soul Shuffle_XS	4/4	4	98			:
ApKb	R&B	440	FA_Soul Shuffle_XS	4/4	1	98			:
ApKb	R&B	441	FB_Soul Shuffle_XS	4/4	1	98			:
ApKb	R&B	442	FC_Soul Shuffle_XS	4/4	1	98			:
ApKb	R&B	443	BA_Soul Shuffle_XS	4/4	1	98			:
ApKb	R&B	444	MA_Soul Swing_XS	4/4	4	124			Acoustic Piano
ApKb	R&B	445	MB_Soul Swing_XS	4/4	4	124			:
ApKb	R&B	446	MC_Soul Swing_XS	4/4	4	124			:
ApKb	R&B	447	FA_Soul Swing_XS	4/4	1	124			:
ApKb	R&B	448	FB_Soul Swing_XS	4/4	1	124			:
ApKb	R&B	449	FC_Soul Swing_XS	4/4	1	124			:
ApKb	R&B	450	BA_Soul Swing_XS	4/4	1	124			:
ApKb	R&B	451	MA_GospelBrothr_XS	4/4	4	108			:
ApKb	R&B	452	MB_GospelBrothr_XS	4/4	4	108			:
ApKb	R&B	453	MC_GospelBrothr_XS	4/4	4	108			:
ApKb	R&B	454	FA_GospelBrothr_XS	4/4	1	108			:
ApKb	R&B	455	FB_GospelBrothr_XS	4/4	1	108			:
ApKb	R&B	456	FC_GospelBrothr_XS	4/4	1	108			:
ApKb	R&B	457	BA_GospelBrothr_XS	4/4	1	108			:
ApKb	R&B	458	MA_New Gospel	4/4	2	90			Electric Piano
ApKb	R&B	459	MB_New Gospel	4/4	2	90			:
ApKb	R&B	460	MC_New Gospel	4/4	2	90			:
ApKb	R&B	461	MD_New Gospel	4/4	2	90			:
ApKb	R&B	462	FA_New Gospel	4/4	1	90			:
ApKb	R&B	463	FB_New Gospel	4/4	2	90			:
ApKb	R&B	464	MA_Clavi1	4/4	1	110			Clavi
ApKb	R&B	465	MA_Clavi2	4/4	1	110			:
ApKb	R&B	466	MA_Clavi3	4/4	1	110			:
ApKb	R&B	467	MA_Clavi4	4/4	1	124			:
ApKb	R&B	468	MA_Clavi5	4/4	1	124			:
ApKb	R&B	469	MA_Clavi6	4/4	1	124			:
ApKb	R&B	470	MA_Clavi7	4/4	1	124			:
ApKb	R&B	471	MA_Super Clavi	4/4	4	101			:
ApKb	R&B	472	MA_Touch Clavi	4/4	1	101			:
ApKb	Elect	473	MA_Ambient 3_ES	4/4	4	88			Electric Piano
ApKb	Elect	474	MB_Ambient 3_ES	4/4	4	88			:
ApKb	Elect	475	MC_Ambient 3_ES	4/4	4	88			:
ApKb	Elect	476	FA_Ambient 3_ES	4/4	1	88			:
ApKb	Elect	477	FB_Ambient 3_ES	4/4	1	88			:
ApKb	Elect	478	FC_Ambient 3_ES	4/4	1	88			:
ApKb	Elect	479	BA_Ambient 3_ES	4/4	1	88			:
ApKb	Elect	480	MA_Disco House_XS	4/4	4	126			:
ApKb	Elect	481	MB_Disco House_XS	4/4	4	126			:
ApKb	Elect	482	MC_Disco House_XS	4/4	4	126			:
ApKb	Elect	483	FA_Disco House_XS	4/4	1	126			:
ApKb	Elect	484	FB_Disco House_XS	4/4	1	126			:
ApKb	Elect	485	FC_Disco House_XS	4/4	1	126			:
ApKb	Elect	486	BA_Disco House_XS	4/4	1	126			:
ApKb	Elect	487	MD_Club House	4/4	1	128			:
ApKb	Elect	488	FC_Club House_ES	4/4					

Main Category	Sub Category	ARP No.	ARP Name	Time Signature	Length	Original Tempo	Accent	Random SFX	Voice Type
ApKb	Elect	493	MA_House P4	4/4	1	130			Acoustic Piano
ApKb	Elect	494	MA_House P5	4/4	1	130			:
ApKb	Elect	495	MA_Deep House1_ES	4/4	1	127			Electric Piano
ApKb	Elect	496	MA_Deep House2_ES	4/4	1	130			:
ApKb	Elect	497	MA_Deep House3_ES	4/4	1	127			:
ApKb	Elect	498	MA_Deep House4_ES	4/4	2	130			:
ApKb	Elect	499	MA_DA House	4/4	2	120			Acoustic Piano
ApKb	Elect	500	MA_Syn Clavi	4/4	1	126			Clavi
ApKb	Jazz	501	MA_AcousticJazz_ES	4/4	4	204			Acoustic Piano
ApKb	Jazz	502	MB_AcousticJazz_ES	4/4	4	204			:
ApKb	Jazz	503	MC_AcousticJazz_ES	4/4	4	204			:
ApKb	Jazz	504	MD_AcousticJazz_ES	4/4	4	204			:
ApKb	Jazz	505	FA_AcousticJazz_ES	4/4	1	204			:
ApKb	Jazz	499	MA_R&R Shuffle_XS	4/4	4	192			:
ApKb	Jazz	507	MB_R&R Shuffle_XS	4/4	4	192			:
ApKb	Jazz	508	MC_R&R Shuffle_XS	4/4	4	192			:
ApKb	Jazz	509	FA_R&R Shuffle_XS	4/4	1	192			:
ApKb	Jazz	510	FB_R&R Shuffle_XS	4/4	1	192			:
ApKb	Jazz	511	FC_R&R Shuffle_XS	4/4	1	192			:
ApKb	Jazz	512	BA_R&R Shuffle_XS	4/4	1	192			:
ApKb	Jazz	513	MA_ShuffleBlues_XS	4/4	4	115			:
ApKb	Jazz	514	MB_ShuffleBlues_XS	4/4	4	115			:
ApKb	Jazz	515	MC_ShuffleBlues_XS	4/4	4	115			:
ApKb	Jazz	516	FA_ShuffleBlues_XS	4/4	1	115			:
ApKb	Jazz	517	FB_ShuffleBlues_XS	4/4	1	115			:
ApKb	Jazz	518	FC_ShuffleBlues_XS	4/4	1	115			:
ApKb	Jazz	519	BA_ShuffleBlues_XS	4/4	1	115			:
ApKb	Jazz	520	MA_Slow Blues 1_XS	4/4	2	49			:
ApKb	Jazz	521	MB_Slow Blues 1_XS	4/4	2	49			:
ApKb	Jazz	522	MC_Slow Blues 1_XS	4/4	2	49			:
ApKb	Jazz	523	FA_Slow Blues 1_XS	4/4	1	49			:
ApKb	Jazz	524	FB_Slow Blues 1_XS	4/4	1	49			:
ApKb	Jazz	525	FC_Slow Blues 1_XS	4/4	1	49			:
ApKb	Jazz	526	BA_Slow Blues 1_XS	4/4	1	49			:
ApKb	Jazz	527	MA_Piano Boogie_XS	4/4	8	160			:
ApKb	Jazz	528	MB_Piano Boogie_XS	4/4	4	160			:
ApKb	Jazz	529	MC_Piano Boogie_XS	4/4	4	160			:
ApKb	Jazz	530	FA_Piano Boogie_XS	4/4	1	160			:
ApKb	Jazz	531	FB_Piano Boogie_XS	4/4	1	160			:
ApKb	Jazz	532	FC_Piano Boogie_XS	4/4	1	160			:
ApKb	Jazz	533	BA_Piano Boogie_XS	4/4	1	160			:
ApKb	World	534	MA_Jumbo Reggae_XS	4/4	4	100			:
ApKb	World	535	MB_Jumbo Reggae_XS	4/4	4	100			:
ApKb	World	536	MC_Jumbo Reggae_XS	4/4	4	100			:
ApKb	World	537	FA_Jumbo Reggae_XS	4/4	1	100			:
ApKb	World	538	FB_Jumbo Reggae_XS	4/4	1	100			:
ApKb	World	539	FC_Jumbo Reggae_XS	4/4	1	100			:
ApKb	World	540	BA_Jumbo Reggae_XS	4/4	1	100			:
ApKb	World	541	MB1_Reggae 2	4/4	2	92			Electric Piano
ApKb	World	542	MD1_Reggae 2	4/4	2	92			:
ApKb	World	543	FA1_Reggae 2	4/4	1	92			:
ApKb	World	544	FB1_Reggae 2	4/4	1	92			:
ApKb	World	545	MA2_Reggae 2	4/4	2	92			Clavi
ApKb	World	546	MB2_Reggae 2	4/4	2	92			:
ApKb	World	547	MD2_Reggae 2	4/4	2	92			:
ApKb	World	548	IA2_Reggae 2	4/4	2	92			:
ApKb	World	549	FA2_Reggae 2	4/4	1	92			:
ApKb	World	550	MA_Salsa 1_XS	4/4	4	177			Acoustic Piano
ApKb	World	551	MB_Salsa 1_XS	4/4	4	177			:
ApKb	World	552	MC_Salsa 1_XS	4/4	4	177			:
ApKb	World	553	FA_Salsa 1_XS	4/4	1	177			:
ApKb	World	554	FB_Salsa 1_XS	4/4	1	177			:
ApKb	World	555	FC_Salsa 1_XS	4/4	1	177			:
ApKb	World	556	BA_Salsa 1_XS	4/4	1	177			:
ApKb	World	557	MA_Salsa 2_ES	4/4	1	123			:
ApKb	World	558	MB_Salsa 2_ES	4/4	1	123			:
ApKb	World	559	MC_Salsa 2	4/4	2	123			:
ApKb	World	560	MD_Salsa 2_ES	4/4	4	123			:
ApKb	World	561	FC_Salsa 2	4/4	2	123			:
ApKb	World	562	MA_AfroCuban_XS	4/4	4	200			:
ApKb	World	563	MB_AfroCuban_XS	4/4	4	200			:
ApKb	World	564	MC_AfroCuban_XS	4/4	4	200			:
ApKb	World	565	FA_AfroCuban_XS	4/4	1	200			:
ApKb	World	566	FB_AfroCuban_XS	4/4	1	200			:
ApKb	World	567	FC_AfroCuban_XS	4/4	1	200			:
ApKb	World	568	BA_AfroCuban_XS	4/4	1	200			:
ApKb	World	569	MA_Montuno_ES	4/4	1	100			:
ApKb	World	570	MC_Montuno_ES	4/4	2	100			:
ApKb	World	571	MD_Montuno_ES	4/4	2	100			:
ApKb	World	572	FA_Montuno_ES	4/4	1	100			:
ApKb	World	573	FC_Montuno_ES	4/4	1	100			:
ApKb	World	574	MA_Samba	4/4	1	120			:
ApKb	World	575	MB_Samba	4/4	4	120			:

Main Category	Sub Category	ARP No.	ARP Name	Time Signature	Length	Original Tempo	Accent	Random SFX	Voice Type
ApKb	World	576	MC_Samba	4/4	4	120			Acoustic Piano
ApKb	World	577	MA_Bomba_XS	4/4	4	99			:
ApKb	World	578	MB_Bomba_XS	4/4	4	99			:
ApKb	World	579	MC_Bomba_XS	4/4	4	99			:
ApKb	World	580	FA_Bomba_XS	4/4	1	99			:
ApKb	World	581	FB_Bomba_XS	4/4	1	99			:
ApKb	World	582	FC_Bomba_XS	4/4	1	99			:
ApKb	World	583	BA_Bomba_XS	4/4	1	99			:
ApKb	World	584	MA_Merengue_XS	4/4	4	130			:
ApKb	World	585	MB_Merengue_XS	4/4	4	130			:
ApKb	World	586	MC_Merengue_XS	4/4	4	130			:
ApKb	World	587	FA_Merengue_XS	4/4	1	130			:
ApKb	World	588	FB_Merengue_XS	4/4	1	130			:
ApKb	World	589	FC_Merengue_XS	4/4	1	130			:
ApKb	World	590	BA_Merengue_XS	4/4	1	130			:
ApKb	World	591	MA_Guaguanco_XS	4/4	4	120			:
ApKb	World	592	MB_Guaguanco_XS	4/4	4	120			:
ApKb	World	593	MC_Guaguanco_XS	4/4	4	120			:
ApKb	World	594	FA_Guaguanco_XS	4/4	1	120			:
ApKb	World	595	FB_Guaguanco_XS	4/4	1	120			:
ApKb	World	596	FC_Guaguanco_XS	4/4	1	120			:
ApKb	World	597	BA_Guaguanco_XS	4/4	1	120			:
ApKb	World	598	MA1_Latin Rock	4/4	2	120			:
ApKb	World	599	MD1_Latin Rock	4/4	4	120			:
ApKb	World	600	FB1_Latin Rock	4/4	1	120			:
ApKb	World	601	MC2_Latin Rock	4/4	2	120			:
ApKb	World	602	FA2_Latin Rock	4/4	1	120			:
ApKb	World	603	MA_Disco Latin_XS	4/4	4	100			:
ApKb	World	604	MB_Disco Latin_XS	4/4	4	100			:
ApKb	World	605	MC_Disco Latin_XS	4/4	4	100			:
ApKb	World	606	FA_Disco Latin_XS	4/4	1	100			:
ApKb	World	607	FB_Disco Latin_XS	4/4	1	100			:
ApKb	World	608	FC_Disco Latin_XS	4/4	1	100			:
ApKb	World	609	BA_Disco Latin_XS	4/4	1	100			:
ApKb	World	610	IA_Latin House_ES	4/4	2	138			:
ApKb	World	611	FA_Latin House_ES	4/4	2	138			:
ApKb	World	612	FC_Latin House_ES	4/4	2	138			:
ApKb	World	613	MA_Piano Latin	4/4	2	120			:
ApKb	Genrl	614	MA_Baroque_XS	4/4	4	88			Harpischord
ApKb	Genrl	615	MB_Baroque_XS	4/4	4	88			:
ApKb	Genrl	616	MC_Baroque_XS	4/4	4	88			:
ApKb	Genrl	617	MD_Baroque_XS	4/4	4	88			:
ApKb	Genrl	618	FA_Baroque_XS	4/4	1	88			:
ApKb	Genrl	619	FB_Baroque_XS	4/4	1	88			:
ApKb	Genrl	620	FC_Baroque_XS	4/4	1	88			:
ApKb	Genrl	621	FD_Baroque_XS	4/4	1	88			:
ApKb	Genrl	622	MA_Pf Arp1	4/4	2	64			Acoustic Piano
ApKb	Genrl	623	MA_Pf Arp2	4/4	2	74			:
ApKb	Genrl	624	MA_Pf Arp3	4/4	2	124			:
ApKb	Genrl	625	MA_Pf Arp4	4/4	2	130			:
ApKb	Genrl	626	MA_Pf Arp5	4/4	2	130			:
ApKb	Genrl	627	MA_Pf Arp6	4/4	2	130			:
ApKb	Genrl	628	MA_Pf Arp7	4/4	2	130			:
ApKb	Genrl	629	MA_Pf Arp8	4/4	2	65			:
ApKb	Genrl	630	MA_Pf Arp9	4/4	1	116			:
ApKb	Genrl	631	MA_Pf Arp10	4/4	1	96			:
ApKb	Genrl	632	MA_Pf Arp11	4/4	1	82			:
ApKb	Genrl	633	MA_Pf Arp12	4/4	1	90			:
ApKb	Genrl	634	MA_Pf Arp13	4/4	1	90			:
ApKb	Genrl	635	MA_Pf Arp14	4/4	1	90			:
ApKb	Genrl	636	MA_Pf Arp15	4/4	1	90			:
ApKb	Genrl	637	MA_Pf Arp16	4/4	1	90			:
ApKb	Genrl	638	MA_Pf Arp17	4/4	1	100			:
ApKb	Genrl	639	MA_Pf Arp18	4/4	1	90			:
ApKb	Genrl	640	MA_Pf Arp19	4/4	1	84			:
ApKb	Genrl	641	MA_Pf Arp20	4/4	1	90			:
ApKb	Genrl	642	MA_Pf Arp21	4/4	1	86			:
ApKb	Genrl	643	MA_Pf Arp22	4/4	1	90			:
ApKb	Genrl	644	MA_Pf Arp23	4/4	1	90			:
ApKb	Genrl	645	MA_Pf Arp24	4/4	2	130			:
ApKb	Genrl	646	MA_Pf Arp25	4/4	2	130			:
ApKb	Genrl	647	MA_Pf Arp26	4/4	2	130			:
ApKb	Genrl	648	MA_Pf Arp27	4/4	2	130			:
ApKb	Genrl	649	MA_Pf Arp28	4/4	2	120			:
ApKb	Genrl	650	MA_Pf Arp29	4/4	1	74			:
Organ	Rock	651	MA_6/8 Ballad_XS	6/8	4	87			Organ
Organ	Rock	652	MB_6/8 Ballad_XS	6/8	4	87			:
Organ	Rock	653	MC_6/8 Ballad_XS	6/8	4	87			:
Organ	Rock	654	FA_6/8 Ballad_XS	6/8	1	87			:
Organ	Rock	655	FB_6/8 Ballad_XS	6/8	1	87			:
Organ	Rock	656	FC_6/8 Ballad_XS	6/8	1	87			:
Organ	Rock	657	BA_6/8 Ballad_XS	6/8	1	87			:
Organ	Rock	658	MA_6/8 Ballad_ES	6/8	4	87			:

Arpeggio Type List

Main Category	Sub Category	ARP No.	ARP Name	Time Signature	Length	Original Tempo	Accent	Random SFX	Voice Type
Organ	Rock	659	MB_6/8 Ballad_ES	6/8	4	87			Organ
Organ	Rock	660	MC_6/8 Ballad_ES	6/8	4	87			:
Organ	Rock	661	FA_6/8 Ballad_ES	6/8	1	87			:
Organ	Rock	662	FB_6/8 Ballad_ES	6/8	1	87			:
Organ	Rock	663	FC_6/8 Ballad_ES	6/8	1	87			:
Organ	Rock	664	BA_6/8 Ballad_ES	6/8	1	87			:
Organ	Rock	665	MA_ProgresRock1_XS	4/4	4	110			:
Organ	Rock	666	MB_ProgresRock1_XS	4/4	3	110			:
Organ	Rock	667	MC_ProgresRock1_XS	4/4	4	110			:
Organ	Rock	668	FA_ProgresRock1_XS	4/4	1	110			:
Organ	Rock	669	FB_ProgresRock1_XS	4/4	1	110			:
Organ	Rock	670	FC_ProgresRock1_XS	4/4	1	110			:
Organ	Rock	671	BA_ProgresRock1_XS	4/4	1	110			:
Organ	Rock	672	MA_ProgresRock1_ES	4/4	4	110			:
Organ	Rock	673	MB_ProgresRock1_ES	4/4	3	110			:
Organ	Rock	674	MC_ProgresRock1_ES	4/4	4	110			:
Organ	Rock	675	FA_ProgresRock1_ES	4/4	1	110			:
Organ	Rock	676	FB_ProgresRock1_ES	4/4	1	110			:
Organ	Rock	677	FC_ProgresRock1_ES	4/4	1	110			:
Organ	Rock	678	BA_ProgresRock1_ES	4/4	1	110			:
Organ	R&B	679	MA_Jazz Funk 1_XS	4/4	4	120			:
Organ	R&B	680	MB_Jazz Funk 1_XS	4/4	4	120			:
Organ	R&B	681	MC_Jazz Funk 1_XS	4/4	4	120			:
Organ	R&B	682	FA_Jazz Funk 1_XS	4/4	1	120			:
Organ	R&B	683	FB_Jazz Funk 1_XS	4/4	1	120			:
Organ	R&B	684	FC_Jazz Funk 1_XS	4/4	1	120			:
Organ	R&B	685	BA_Jazz Funk 1_XS	4/4	1	120			:
Organ	R&B	686	MB_Jazz Funk 2	4/4	4	120			:
Organ	R&B	687	MA_Funk Organ1*	4/4	2	110			:
Organ	R&B	688	MA_Funk Organ2*	4/4	2	110			:
Organ	R&B	689	MD_Hip Hop 1_ES	4/4	2	105			:
Organ	R&B	690	FC_Hip Hop 1_ES	4/4	2	105			:
Organ	R&B	691	MA_Soul 1_XS	4/4	2	116			:
Organ	R&B	692	MB_Soul 1_XS	4/4	2	116			:
Organ	R&B	693	MC_Soul 1_XS	4/4	2	116			:
Organ	R&B	694	FA_Soul 1_XS	4/4	1	116			:
Organ	R&B	695	FB_Soul 1_XS	4/4	1	116			:
Organ	R&B	696	FC_Soul 1_XS	4/4	1	116			:
Organ	R&B	697	BA_Soul 1_XS	4/4	1	116			:
Organ	R&B	698	MA_Soul 2	4/4	1	120			:
Organ	R&B	699	MB_Soul 2	4/4	4	120			:
Organ	R&B	700	FB_Soul 2_ES	4/4	1	120			:
Organ	Elect	701	MA_House Organ1	4/4	1	130			:
Organ	Elect	702	MA_House Organ2	4/4	1	130			:
Organ	Elect	703	MA_House Organ3	4/4	1	130			:
Organ	Elect	704	MA_House Organ4	4/4	1	130			:
Organ	Elect	705	MA_House Organ5	4/4	2	126			:
Organ	Jazz	706	MA_Slow Blues 2_XS	4/4	4	72			:
Organ	Jazz	707	MB_Slow Blues 2_XS	4/4	4	72			:
Organ	Jazz	708	MC_Slow Blues 2_XS	4/4	4	72			:
Organ	Jazz	709	FA_Slow Blues 2_XS	4/4	1	72			:
Organ	Jazz	710	FB_Slow Blues 2_XS	4/4	1	72			:
Organ	Jazz	711	FC_Slow Blues 2_XS	4/4	1	72			:
Organ	Jazz	712	BA_Slow Blues 2_XS	4/4	1	72			:
Organ	Jazz	713	MA_Slow Blues 2_ES	4/4	4	72			:
Organ	Jazz	714	MB_Slow Blues 2_ES	4/4	4	72			:
Organ	Jazz	715	MC_Slow Blues 2_ES	4/4	4	72			:
Organ	Jazz	716	FA_Slow Blues 2_ES	4/4	1	72			:
Organ	Jazz	717	FB_Slow Blues 2_ES	4/4	1	72			:
Organ	Jazz	718	FC_Slow Blues 2_ES	4/4	1	72			:
Organ	Jazz	719	BA_Slow Blues 2_ES	4/4	1	72			:
Organ	World	720	MA_Reggae 1	4/4	4	102			:
Organ	World	721	MB_Reggae 1	4/4	4	102			:
Organ	World	722	MD_Reggae 1	4/4	4	90			:
Organ	World	723	FB_Reggae 1	4/4	1	102			:
Organ	World	724	MA_Reggae 2	4/4	1	92			:
Organ	World	725	MB_Reggae 2	4/4	2	92			:
Organ	World	726	MC_Reggae 2	4/4	2	92			:
Organ	World	727	MD_Reggae 2	4/4	1	92			:
Organ	World	728	IA_Reggae 2	4/4	2	92			:
Organ	World	729	FB_Reggae 2	4/4	1	92			:
Organ	World	730	MA_ReggaeOrgan1*	4/4	2	120			:
Organ	World	731	MA_ReggaeOrgan2*	4/4	1	120			:
Organ	World	732	MA_Latin Rock	4/4	2	120			:
Organ	World	733	MB_Latin Rock	4/4	2	120			:
Organ	World	734	MA_Latin Organ*	4/4	1	110			:
GIPI	Rock	735	MA_OverdriveG1	4/4	4	120			Od/Dist Guitar
GIPI	Rock	736	MA_OverdriveG2_ES	4/4	4	120			:
GIPI	Rock	737	MA_OverdriveG3_ES	4/4	4	120			:
GIPI	Rock	738	MA_OverdriveG4_ES	4/4	4	120			:
GIPI	Rock	739	MA_OverdriveG5_ES	4/4	4	120			:
GIPI	Rock	740	MA_Guitar Over1	1/4	4	180			:
GIPI	Rock	741	MA_Guitar Over2_ES	1/4	4	120			:

Main Category	Sub Category	ARP No.	ARP Name	Time Signature	Length	Original Tempo	Accent	Random SFX	Voice Type
GIPI	Rock	742	MA_ContempRock_XS	4/4	4	126			Od/Dist Guitar
GIPI	Rock	743	MB_ContempRock_XS	4/4	4	126			:
GIPI	Rock	744	MC_ContempRock_XS	4/4	4	126			:
GIPI	Rock	745	FA_ContempRock_XS	4/4	1	126			:
GIPI	Rock	746	FB_ContempRock_XS	4/4	1	126			:
GIPI	Rock	747	FC_ContempRock_XS	4/4	1	126			:
GIPI	Rock	748	BA_ContempRock_XS	4/4	1	126			:
GIPI	Rock	749	MA1_70s Rock	4/4	2	130			Clean Guitar
GIPI	Rock	750	MB1_70s Rock	4/4	2	130			:
GIPI	Rock	751	MC1_70s Rock	4/4	4	130			:
GIPI	Rock	752	MD1_70s Rock_ES	4/4	2	130			:
GIPI	Rock	753	MB2_70s Rock_ES	4/4	4	130			Od/Dist Guitar
GIPI	Rock	754	MC2_70s Rock_ES	4/4	2	130			:
GIPI	Rock	755	MD2_70s Rock_ES	4/4	2	130			:
GIPI	Rock	756	FC2_70s Rock_ES	4/4	2	130			:
GIPI	Rock	757	MA3_70s Rock_ES	4/4	2	130			:
GIPI	Rock	758	MB3_70s Rock_ES	4/4	2	130			:
GIPI	Rock	759	MC3_70s Rock_ES	4/4	1	130			:
GIPI	Rock	760	MD3_70s Rock_ES	4/4	4	130			:
GIPI	Rock	761	MA_OverTheTop1	4/4	2	120			"Over The Top"
GIPI	Rock	762	MA_OverTheTop2	4/4	2	120			:
GIPI	Rock	763	MA_OverTheTop3	4/4	2	120			:
GIPI	Rock	764	MA_OverTheTop4	4/4	4	120			:
GIPI	Rock	765	MA_OverTheTop5	4/4	4	120			:
GIPI	Rock	766	MA_AlternaRock1_ES	4/4	4	97			Od/Dist Guitar
GIPI	Rock	767	MB_AlternaRock1_ES	4/4	4	97			:
GIPI	Rock	768	MC_AlternaRock1_ES	4/4	4	97			:
GIPI	Rock	769	FA_AlternaRock1_ES	4/4	1	97			:
GIPI	Rock	770	FB_AlternaRock1_ES	4/4	1	97			:
GIPI	Rock	771	FC_AlternaRock1_ES	4/4	1	97			:
GIPI	Rock	772	BA_AlternaRock1_ES	4/4	1	97			:
GIPI	Rock	773	MA_AlternaRock2_ES	4/4	4	100			:
GIPI	Rock	774	MB_AlternaRock2_ES	4/4	4	100			:
GIPI	Rock	775	MC_AlternaRock2_ES	4/4	4	100			:
GIPI	Rock	776	FA_AlternaRock2_ES	4/4	1	100			:
GIPI	Rock	777	FB_AlternaRock2_ES	4/4	1	100			:
GIPI	Rock	778	FC_AlternaRock2_ES	4/4	1	100			:
GIPI	Rock	779	BA_AlternaRock2_ES	4/4	2	100			:
GIPI	Rock	780	MC1_Xover Rock_ES	4/4	2	100			:
GIPI	Rock	781	MD1_Xover Rock_ES	4/4	2	100			:
GIPI	Rock	782	FB1_Xover Rock_ES	4/4	1	100			:
GIPI	Rock	783	FC1_Xover Rock_ES	4/4	2	100			:
GIPI	Rock	784	MA2_Xover Rock_ES	4/4	2	100			:
GIPI	Rock	785	MB2_Xover Rock_ES	4/4	1	100			:
GIPI	Rock	786	IA2_Xover Rock_ES	4/4	2	100			Clean Guitar
GIPI	Rock	787	FA2_Xover Rock_ES	4/4	1	100			:
GIPI	Rock	788	MA_Guitar Pop 1_XS	4/4	4	100			Acoustic Guitar
GIPI	Rock	789	MB_Guitar Pop 1_XS	4/4	4	100			:
GIPI	Rock	790	MC_Guitar Pop 1_XS	4/4	4	100			:
GIPI	Rock	791	FA_Guitar Pop 1_XS	4/4	1	100			:
GIPI	Rock	792	FB_Guitar Pop 1_XS	4/4	1	100			:
GIPI	Rock	793	FC_Guitar Pop 1_XS	4/4	1	100			:
GIPI	Rock	794	BA_Guitar Pop 1_XS	4/4	1	100			:
GIPI	Rock	795	MA1_Guitar Pop 2	4/4	2	90			:
GIPI	Rock	796	MB1_Guitar Pop 2	4/4	1	90			:
GIPI	Rock	797	MC1_Guitar Pop 2	4/4	2	90			:
GIPI	Rock	798	IA1_Guitar Pop 2	4/4	1	90			:
GIPI	Rock	799	MA2_Guitar Pop 2	4/4	1	90			:
GIPI	Rock	800	IA2_Guitar Pop 2	4/4	1	90			Clean Guitar
GIPI	Rock	801	MA_Unplugged 3_XS	4/4	4	113			Acoustic Guitar
GIPI	Rock	802	MB_Unplugged 3_XS	4/4	4	113			:
GIPI	Rock	803	MC_Unplugged 3_XS	4/4	4	113			:
GIPI	Rock	804	FA_Unplugged 3_XS	4/4	1	113			:
GIPI	Rock	805	FB_Unplugged 3_XS	4/4	1	113			:
GIPI	Rock	806	FC_Unplugged 3_XS	4/4	1	113			:
GIPI	Rock	807	BA_Unplugged 3_XS	4/4	1	113			:
GIPI	Rock	808	MA_Unplugged 3_ES	4/4	4	113			:
GIPI	Rock	809	MB_Unplugged 3_ES	4/4	4	113			:
GIPI	Rock	810	MC_Unplugged 3_ES	4/4	4	113			:
GIPI	Rock	811	FA_Unplugged 3_ES	4/4	1	113			:
GIPI	Rock	812	FB_Unplugged 3_ES	4/4	1	113			:
GIPI	Rock	813	FC_Unplugged 3_ES	4/4	1	113			:
GIPI	Rock	814	BA_Unplugged 3_ES	4/4	1	113			:
GIPI	Rock	815	MA_Unplugged 4	4/4	4	120			:
GIPI	Rock	816	MB_Unplugged 4	4/4	2	120			:
GIPI	Rock	817	MC_Unplugged 4	4/4	2	120			:
GIPI	Rock	818	MD_Unplugged 4	4/4	2	120			:
GIPI	Rock	819	FA_Unplugged 4	4/4	1	120			:
GIPI	Rock	820	FB_Unplugged 4	4/4	1	120			:
GIPI	Rock	821	MA1_FingerPickin_ES	4/4	2	94			:
GIPI	Rock	822	MB1_FingerPickin_ES	4/4	2	94			:
GIPI	Rock	823	MC1_FingerPickin_ES	4/4	2	94			:
GIPI	Rock	824	MD1_FingerPickin_ES	4/4	3	94			:

Main Category	Sub Category	ARP No.	ARP Name	Time Signature	Length	Original Tempo	Accent	Random SFX	Voice Type
GIPI	Rock	825	IA1_FingerPickin	4/4	1	94			Acoustic Guitar
GIPI	Rock	826	FA1_FingerPickin_ES	4/4	1	94			:
GIPI	Rock	827	FB1_FingerPickin_ES	4/4	1	94			:
GIPI	Rock	828	MA2_FingerPickin	4/4	2	94			:
GIPI	Rock	829	MB2_FingerPickin	4/4	2	94			:
GIPI	Rock	830	MC2_FingerPickin	4/4	2	94			:
GIPI	Rock	831	MD2_FingerPickin	4/4	2	94			:
GIPI	Rock	832	IA2_FingerPickin	4/4	2	94			:
GIPI	Rock	833	FA2_FingerPickin	4/4	1	94			:
GIPI	Rock	834	FB2_FingerPickin	4/4	1	94			:
GIPI	Rock	835	MA_Pickin1	4/4	3	120			:
GIPI	Rock	836	MA_Pickin2	4/4	2	120			:
GIPI	Rock	837	MA_Pickin3	4/4	2	120			:
GIPI	Rock	838	MA1_Folk Rock_ES	4/4	2	120			:
GIPI	Rock	839	MB1_Folk Rock_ES	4/4	2	120			:
GIPI	Rock	840	IA1_Folk Rock_ES	4/4	1	120			:
GIPI	Rock	841	MA2_Folk Rock_ES	4/4	2	120			:
GIPI	Rock	842	MB2_Folk Rock_ES	4/4	2	120			:
GIPI	Rock	843	MC2_Folk Rock_ES	4/4	2	120			:
GIPI	Rock	844	IA2_Folk Rock_ES	4/4	1	120			:
GIPI	Rock	845	MC3_Folk Rock_ES	4/4	2	120			Clean Guitar
GIPI	Rock	846	MD3_Folk Rock_ES	4/4	2	120			:
GIPI	Rock	847	FA3_Folk Rock_ES	4/4	1	120			:
GIPI	Rock	848	MA_12 GuitarA1_ES	4/4	4	120			Acoustic Guitar
GIPI	Rock	849	MA_12 GuitarA2_ES	4/4	4	120			:
GIPI	Rock	850	MA_12 GuitarA3_ES	4/4	4	120			:
GIPI	Rock	851	MA_12 GuitarA4_ES	4/4	4	120			:
GIPI	Rock	852	MA_12 GuitarA5_ES	4/4	4	120			:
GIPI	Rock	853	MA_12 GuitarB1	4/4	1	97			:
GIPI	Rock	854	MA_12 GuitarB2	4/4	1	100			:
GIPI	Rock	855	MA_Worship Fast_XS	4/4	8	114			:
GIPI	Rock	856	MB_Worship Fast_XS	4/4	4	114			:
GIPI	Rock	857	MC_Worship Fast_XS	4/4	4	114			:
GIPI	Rock	858	FA_Worship Fast_XS	4/4	1	114			:
GIPI	Rock	859	FB_Worship Fast_XS	4/4	1	114			:
GIPI	Rock	860	FC_Worship Fast_XS	4/4	1	114			:
GIPI	Rock	861	BA_Worship Fast_XS	4/4	1	114			:
GIPI	Rock	862	MA_New Country_XS	4/4	2	118			:
GIPI	Rock	863	MB_New Country_XS	4/4	4	118			:
GIPI	Rock	864	MC_New Country_XS	4/4	2	118			:
GIPI	Rock	865	FA_New Country_XS	4/4	1	118			:
GIPI	Rock	866	FB_New Country_XS	4/4	1	118			:
GIPI	Rock	867	FC_New Country_XS	4/4	1	118			:
GIPI	Rock	868	BA_New Country_XS	4/4	1	118			:
GIPI	Rock	869	MA_New Country	4/4	2	118			:
GIPI	Rock	870	MB_New Country	4/4	4	118			:
GIPI	Rock	871	MC_New Country	4/4	2	118			:
GIPI	Rock	872	FA_New Country	4/4	1	118			:
GIPI	Rock	873	FB_New Country	4/4	1	118			:
GIPI	Rock	874	FC_New Country	4/4	1	118			:
GIPI	Rock	875	BA_New Country	4/4	1	118			:
GIPI	Rock	876	MA_BritPopSwing_XS	4/4	2	110			Clean Guitar
GIPI	Rock	877	MB_BritPopSwing_XS	4/4	2	110			:
GIPI	Rock	878	MC_BritPopSwing_XS	4/4	2	110			:
GIPI	Rock	879	FA_BritPopSwing_XS	4/4	1	110			:
GIPI	Rock	880	FB_BritPopSwing_XS	4/4	1	110			:
GIPI	Rock	881	FC_BritPopSwing_XS	4/4	1	110			:
GIPI	Rock	882	BA_BritPopSwing_XS	4/4	1	110			:
GIPI	Rock	883	MA_8Beat Ballad_XS	4/4	4	101			Acoustic Guitar
GIPI	Rock	884	MB_8Beat Ballad_XS	4/4	4	101			:
GIPI	Rock	885	MC_8Beat Ballad_XS	4/4	4	101			:
GIPI	Rock	886	FA_8Beat Ballad_XS	4/4	1	101			:
GIPI	Rock	887	FB_8Beat Ballad_XS	4/4	1	101			:
GIPI	Rock	888	FC_8Beat Ballad_XS	4/4	1	101			:
GIPI	Rock	889	BA_8Beat Ballad_XS	4/4	1	101			:
GIPI	Rock	890	MA_8Beat Ballad	4/4	4	101			:
GIPI	Rock	891	MB_8Beat Ballad	4/4	4	101			:
GIPI	Rock	892	MC_8Beat Ballad	4/4	4	101			:
GIPI	Rock	893	FA_8Beat Ballad	4/4	1	101			:
GIPI	Rock	894	FB_8Beat Ballad	4/4	1	101			:
GIPI	Rock	895	FC_8Beat Ballad	4/4	1	101			:
GIPI	Rock	896	BA_8Beat Ballad	4/4	1	101			:
GIPI	Rock	897	MA_8Beat Basic_XS	4/4	4	120			Clean Guitar
GIPI	Rock	898	MB_8Beat Basic_XS	4/4	4	120			:
GIPI	Rock	899	MC_8Beat Basic_XS	4/4	4	120			:
GIPI	Rock	900	FA_8Beat Basic_XS	4/4	1	120			:
GIPI	Rock	901	FB_8Beat Basic_XS	4/4	1	120			:
GIPI	Rock	902	FC_8Beat Basic_XS	4/4	1	120			:
GIPI	Rock	903	BA_8Beat Basic_XS	4/4	1	120			:
GIPI	Rock	904	MA_8Beat Basic_ES	4/4	4	120			:
GIPI	Rock	905	MB_8Beat Basic_ES	4/4	4	120			:
GIPI	Rock	906	MC_8Beat Basic_ES	4/4	4	120			:
GIPI	Rock	907	FA_8Beat Basic_ES	4/4	1	120			:

Main Category	Sub Category	ARP No.	ARP Name	Time Signature	Length	Original Tempo	Accent	Random SFX	Voice Type
GIPI	Rock	908	FB_8Beat Basic_ES	4/4	1	120			Clean Guitar
GIPI	Rock	909	FC_8Beat Basic_ES	4/4	1	120			:
GIPI	Rock	910	BA_8Beat Basic_ES	4/4	1	120			:
GIPI	Rock	911	MA1_8Beat Rock_XS	4/4	4	75			:
GIPI	Rock	912	MB1_8Beat Rock_XS	4/4	4	75			:
GIPI	Rock	913	MC1_8Beat Rock_XS	4/4	4	75			:
GIPI	Rock	914	FA1_8Beat Rock_XS	4/4	1	75			:
GIPI	Rock	915	FB1_8Beat Rock_XS	4/4	1	75			:
GIPI	Rock	916	FC1_8Beat Rock_XS	4/4	1	75			:
GIPI	Rock	917	BA1_8Beat Rock_XS	4/4	1	75			:
GIPI	Rock	918	MA1_8Beat Rock_ES	4/4	4	75			:
GIPI	Rock	919	MB1_8Beat Rock_ES	4/4	4	75			:
GIPI	Rock	920	MC1_8Beat Rock_ES	4/4	4	75			:
GIPI	Rock	921	FA1_8Beat Rock_ES	4/4	1	75			:
GIPI	Rock	922	FB1_8Beat Rock_ES	4/4	1	75			:
GIPI	Rock	923	FC1_8Beat Rock_ES	4/4	1	75			:
GIPI	Rock	924	BA1_8Beat Rock_ES	4/4	1	75			:
GIPI	Rock	925	MA2_8Beat Rock_XS	4/4	4	75			Od/Dist Guitar
GIPI	Rock	926	MB2_8Beat Rock_XS	4/4	4	75			:
GIPI	Rock	927	MC2_8Beat Rock_XS	4/4	4	75			:
GIPI	Rock	928	FA2_8Beat Rock_XS	4/4	1	75			:
GIPI	Rock	929	FB2_8Beat Rock_XS	4/4	1	75			:
GIPI	Rock	930	FC2_8Beat Rock_XS	4/4	1	75			:
GIPI	Rock	931	BA2_8Beat Rock_XS	4/4	1	75			:
GIPI	Rock	932	MA2_8Beat Rock_ES	4/4	4	75			:
GIPI	Rock	933	MB2_8Beat Rock_ES	4/4	4	75			:
GIPI	Rock	934	MC2_8Beat Rock_ES	4/4	4	75			:
GIPI	Rock	935	FA2_8Beat Rock_ES	4/4	1	75			:
GIPI	Rock	936	FB2_8Beat Rock_ES	4/4	1	75			:
GIPI	Rock	937	FC2_8Beat Rock_ES	4/4	1	75			:
GIPI	Rock	938	BA2_8Beat Rock_ES	4/4	1	75			:
GIPI	Rock	939	MA_8Beat Soft_XS	4/4	4	100			Acoustic Guitar
GIPI	Rock	940	MB_8Beat Soft_XS	4/4	4	100			:
GIPI	Rock	941	MC_8Beat Soft_XS	4/4	4	100			:
GIPI	Rock	942	FA_8Beat Soft_XS	4/4	1	100			:
GIPI	Rock	943	FB_8Beat Soft_XS	4/4	1	100			:
GIPI	Rock	944	FC_8Beat Soft_XS	4/4	1	100			:
GIPI	Rock	945	BA_8Beat Soft_XS	4/4	1	100			:
GIPI	Rock	946	MA_8Beat Soft_ES	4/4	4	100			:
GIPI	Rock	947	MB_8Beat Soft_ES	4/4	4	100			:
GIPI	Rock	948	MC_8Beat Soft_ES	4/4	4	100			:
GIPI	Rock	949	FA_8Beat Soft_ES	4/4	1	100			:
GIPI	Rock	950	FB_8Beat Soft_ES	4/4	1	100			:
GIPI	Rock	951	FC_8Beat Soft_ES	4/4	1	100			:
GIPI	Rock	952	BA_8Beat Soft_ES	4/4	1	100			:
GIPI	Rock	953	MA1_Soft Rock_ES	4/4	4	120			:
GIPI	Rock	954	MB1_Soft Rock_ES	4/4	4	120			:
GIPI	Rock	955	MC1_Soft Rock_ES	4/4	2	120			:
GIPI	Rock	956	MD1_Soft Rock_ES	4/4	2	120			:
GIPI	Rock	957	IA1_Soft Rock_ES	4/4	1	120			:
GIPI	Rock	958	FA1_Soft Rock_ES	4/4	1	120			:
GIPI	Rock	959	FB1_Soft Rock_ES	4/4	1	120			:
GIPI	Rock	960	MD2_Soft Rock_ES	4/4	2	120			Od/Dist Guitar
GIPI	Rock	961	FB2_Soft Rock_ES	4/4	1	120			:
GIPI	Rock	962	MA_Slowfeel	4/4	1	74			Acoustic Guitar
GIPI	Rock	963	MB_Slowfeel	4/4	1	74			:
GIPI	Rock	964	MC_Slowfeel	4/4	1	74			Clean Guitar
GIPI	Rock	965	MA_16Bt Ballad1_XS	4/4	4	75			:
GIPI	Rock	966	MB_16Bt Ballad1_XS	4/4	4	75			:
GIPI	Rock	967	MC_16Bt Ballad1_XS	4/4	4	75			:
GIPI	Rock	968	FA_16Bt Ballad1_XS	4/4	1	75			:
GIPI	Rock	969	FB_16Bt Ballad1_XS	4/4	1	75			:
GIPI	Rock	970	FC_16Bt Ballad1_XS	4/4	1	75			:
GIPI	Rock	971	BA_16Bt Ballad1_XS	4/4	1	75			:
GIPI	Rock	972	MA_16Bt Ballad1_ES	4/4	4	75			:
GIPI	Rock	973	MB_16Bt Ballad1_ES	4/4	4	75			:
GIPI	Rock	974	MC_16Bt Ballad1_ES	4/4	4	75			:
GIPI	Rock	975	FA_16Bt Ballad1_ES	4/4	1	75			:
GIPI	Rock	976	FB_16Bt Ballad1_ES	4/4	1	75			:
GIPI	Rock	977	FC_16Bt Ballad1_ES	4/4	1	75			:
GIPI	Rock	978	BA_16Bt Ballad1_ES	4/4	1	75			:
GIPI	Rock	979	MA_16BeatBasic1_XS	4/4	4	90			:
GIPI	Rock	980	MB_16BeatBasic1_XS	4/4	4	90			:
GIPI	Rock	981	MC_16BeatBasic1_XS	4/4	4	90			:
GIPI	Rock	982	FA_16BeatBasic1_XS	4/4	1	90			:
GIPI	Rock	983	FB_16BeatBasic1_XS	4/4	1	90			:
GIPI	Rock	984	FC_16BeatBasic1_XS	4/4	1	90			:
GIPI	Rock	985	BA_16BeatBasic1_XS	4/4	1	90			:
GIPI	Rock	986	MA_16BeatBasic1_ES	4/4	4	90			:
GIPI	Rock	987	MB_16BeatBasic1_ES	4/4	4	90			:
GIPI	Rock	988	MC_16BeatBasic1_ES	4/4	4	90			:
GIPI	Rock	989	FA_16BeatBasic1_ES	4/4	1	90			:
GIPI	Rock	990	FB_16BeatBasic1_ES	4/4	1	90			:

Arpeggio Type List

Main Category	Sub Category	ARP No.	ARP Name	Time Signature	Length	Original Tempo	Accent	Random SFX	Voice Type
GIPI	Rock	991	FC_16BeatBasic1_ES	4/4	1	90			Clean Guitar
GIPI	Rock	992	BA_16BeatBasic1_ES	4/4	1	90			:
GIPI	Rock	993	MA_16Beat Rock_XS	4/4	4	86			*Over The Top*
GIPI	Rock	994	MB_16Beat Rock_XS	4/4	4	86			:
GIPI	Rock	995	MC_16Beat Rock_XS	4/4	4	86			:
GIPI	Rock	996	FA_16Beat Rock_XS	4/4	1	86			:
GIPI	Rock	997	FB_16Beat Rock_XS	4/4	1	86			:
GIPI	Rock	998	FC_16Beat Rock_XS	4/4	1	86			:
GIPI	Rock	999	BA_16Beat Rock_XS	4/4	1	86			:
GIPI	Rock	1000	MA_16Beat Rock	4/4	4	86			:
GIPI	Rock	1001	MB_16Beat Rock_ES	4/4	4	86			:
GIPI	Rock	1002	MC_16Beat Rock_ES	4/4	4	86			:
GIPI	Rock	1003	FA_16Beat Rock	4/4	1	86			:
GIPI	Rock	1004	FB_16Beat Rock_ES	4/4	1	86			:
GIPI	Rock	1005	FC_16Beat Rock_ES	4/4	1	86			:
GIPI	Rock	1006	BA_16Beat Rock_ES	4/4	1	86			:
GIPI	Rock	1007	MA_Analog Pop	4/4	2	93			Clean Guitar
GIPI	Rock	1008	MC_Analog Pop	4/4	1	93			:
GIPI	Rock	1009	IA_Analog Pop	4/4	1	93			:
GIPI	Rock	1010	MA_6/8 Pop_XS	4/4	4	100			Od/Dist Guitar
GIPI	Rock	1011	MB_6/8 Pop_XS	4/4	4	100			:
GIPI	Rock	1012	MC_6/8 Pop_XS	4/4	4	100			:
GIPI	Rock	1013	FA_6/8 Pop_XS	4/4	1	100			:
GIPI	Rock	1014	FB_6/8 Pop_XS	4/4	1	100			:
GIPI	Rock	1015	FC_6/8 Pop_XS	4/4	1	100			:
GIPI	Rock	1016	BA_6/8 Pop_XS	4/4	1	100			:
GIPI	Rock	1017	MA_6/8 Pop_ES	4/4	4	100			:
GIPI	Rock	1018	MB_6/8 Pop_ES	4/4	4	100			:
GIPI	Rock	1019	MC_6/8 Pop_ES	4/4	4	100			:
GIPI	Rock	1020	FA_6/8 Pop_ES	4/4	1	100			:
GIPI	Rock	1021	FB_6/8 Pop_ES	4/4	1	100			:
GIPI	Rock	1022	FC_6/8 Pop_ES	4/4	1	100			:
GIPI	Rock	1023	BA_6/8 Pop_ES	4/4	1	100			:
GIPI	Rock	1024	MA_6/8 Ballad_XS	6/8	4	87			:
GIPI	Rock	1025	MB_6/8 Ballad_XS	6/8	4	87			:
GIPI	Rock	1026	MC_6/8 Ballad_XS	6/8	4	87			:
GIPI	Rock	1027	FA_6/8 Ballad_XS	6/8	1	87			:
GIPI	Rock	1028	FB_6/8 Ballad_XS	6/8	1	87			:
GIPI	Rock	1029	FC_6/8 Ballad_XS	6/8	1	87			:
GIPI	Rock	1030	BA_6/8 Ballad_XS	6/8	1	87			:
GIPI	Rock	1031	MA_6/8 Ballad_ES	6/8	4	87			:
GIPI	Rock	1032	MB_6/8 Ballad_ES	6/8	4	87			:
GIPI	Rock	1033	MC_6/8 Ballad_ES	6/8	4	87			:
GIPI	Rock	1034	FA_6/8 Ballad_ES	6/8	1	87			:
GIPI	Rock	1035	FB_6/8 Ballad_ES	6/8	1	87			:
GIPI	Rock	1036	FC_6/8 Ballad_ES	6/8	1	87			:
GIPI	Rock	1037	BA_6/8 Ballad_ES	6/8	1	87			:
GIPI	Rock	1038	MA_ProgresRock1_XS	4/4	4	110			*DriveWah (2handGr)*
GIPI	Rock	1039	MB_ProgresRock1_XS	4/4	3	110			:
GIPI	Rock	1040	MC_ProgresRock1_XS	4/4	4	110			:
GIPI	Rock	1041	FA_ProgresRock1_XS	4/4	1	110			:
GIPI	Rock	1042	FB_ProgresRock1_XS	4/4	1	110			:
GIPI	Rock	1043	FC_ProgresRock1_XS	4/4	1	110			:
GIPI	Rock	1044	BA_ProgresRock1_XS	4/4	1	110			:
GIPI	Rock	1045	MA_ProgresRock1_ES	4/4	4	110			:
GIPI	Rock	1046	MB_ProgresRock1_ES	4/4	3	110			:
GIPI	Rock	1047	MC_ProgresRock1_ES	4/4	4	110			:
GIPI	Rock	1048	FA_ProgresRock1_ES	4/4	1	110			:
GIPI	Rock	1049	FB_ProgresRock1_ES	4/4	1	110			:
GIPI	Rock	1050	FC_ProgresRock1_ES	4/4	1	110			:
GIPI	Rock	1051	BA_ProgresRock1_ES	4/4	1	110			:
GIPI	Rock	1052	MA_ProgresRock2_XS	4/4	4	120			Clean Guitar
GIPI	Rock	1053	MB_ProgresRock2_XS	4/4	4	120			:
GIPI	Rock	1054	MC_ProgresRock2_XS	4/4	4	120			:
GIPI	Rock	1055	FA_ProgresRock2_XS	4/4	1	120			:
GIPI	Rock	1056	FB_ProgresRock2_XS	4/4	1	120			:
GIPI	Rock	1057	FC_ProgresRock2_XS	4/4	1	120			:
GIPI	Rock	1058	BA_ProgresRock2_XS	4/4	1	120			:
GIPI	Rock	1059	MA_ProgresRock2_ES	4/4	4	120			:
GIPI	Rock	1060	MB_ProgresRock2_ES	4/4	4	120			:
GIPI	Rock	1061	MC_ProgresRock2_ES	4/4	4	120			:
GIPI	Rock	1062	FA_ProgresRock2_ES	4/4	1	120			:
GIPI	Rock	1063	FB_ProgresRock2_ES	4/4	1	120			:
GIPI	Rock	1064	FC_ProgresRock2_ES	4/4	1	120			:
GIPI	Rock	1065	BA_ProgresRock2_ES	4/4	1	120			:
GIPI	Rock	1066	MA_Rock Guitar1	4/4	1	120			Od/Dist Guitar
GIPI	Rock	1067	MA_Rock Guitar2	4/4	1	120			:
GIPI	Rock	1068	MA_Rock Guitar3	4/4	1	120			:
GIPI	R&B	1069	MA_Funk 3	4/4	2	132			Clean Guitar
GIPI	R&B	1070	MB_Funk 3	4/4	1	132			:
GIPI	R&B	1071	MC_Funk 3	4/4	1	132			:
GIPI	R&B	1072	MD_Funk 3	4/4	4	132			:
GIPI	R&B	1073	IA_Funk 3	4/4	1	132			:

Main Category	Sub Category	ARP No.	ARP Name	Time Signature	Length	Original Tempo	Accent	Random SFX	Voice Type
GIPI	R&B	1074	FB_Funk 3	4/4	1	132			Clean Guitar
GIPI	R&B	1075	FC_Funk 3	4/4	2	132			:
GIPI	R&B	1076	MA_Cool Funk_ES	4/4	2	96			:
GIPI	R&B	1077	MB_Cool Funk	4/4	1	96			:
GIPI	R&B	1078	MD_Cool Funk	4/4	2	96			:
GIPI	R&B	1079	IA_Cool Funk	4/4	2	96			:
GIPI	R&B	1080	FC_Cool Funk	4/4	1	96			:
GIPI	R&B	1081	MA_Jazz Funk 2	4/4	2	120			:
GIPI	R&B	1082	MB_Jazz Funk 2	4/4	2	120			:
GIPI	R&B	1083	MC_Jazz Funk 2	4/4	1	120			:
GIPI	R&B	1084	MD_Jazz Funk 2	4/4	2	120			:
GIPI	R&B	1085	IA_Jazz Funk 2	4/4	2	120			:
GIPI	R&B	1086	FB_Jazz Funk 2	4/4	1	120			:
GIPI	R&B	1087	FC_Jazz Funk 2	4/4	1	120			:
GIPI	R&B	1088	MA_Funky1	4/4	2	120			:
GIPI	R&B	1089	MA_Funky2	4/4	2	120			:
GIPI	R&B	1090	MA_Funky3	4/4	2	120			:
GIPI	R&B	1091	MA_Funky4	4/4	1	120			:
GIPI	R&B	1092	MA_Funk Guitar	4/4	2	116			Mute Guitar
GIPI	R&B	1093	MA_Pop Shuffle1_XS	4/4	4	94			Clean Guitar
GIPI	R&B	1094	MB_Pop Shuffle1_XS	4/4	4	94			:
GIPI	R&B	1095	MC_Pop Shuffle1_XS	4/4	4	94			:
GIPI	R&B	1096	FA_Pop Shuffle1_XS	4/4	1	94			:
GIPI	R&B	1097	FB_Pop Shuffle1_XS	4/4	1	94			:
GIPI	R&B	1098	FC_Pop Shuffle1_XS	4/4	1	94			:
GIPI	R&B	1099	BA_Pop Shuffle1_XS	4/4	1	94			:
GIPI	R&B	1100	MA_Pop Shuffle1_ES	4/4	4	94			:
GIPI	R&B	1101	MB_Pop Shuffle1_ES	4/4	4	94			:
GIPI	R&B	1102	MC_Pop Shuffle1_ES	4/4	4	94			:
GIPI	R&B	1103	FA_Pop Shuffle1_ES	4/4	1	94			:
GIPI	R&B	1104	FB_Pop Shuffle1_ES	4/4	1	94			:
GIPI	R&B	1105	FC_Pop Shuffle1_ES	4/4	1	94			:
GIPI	R&B	1106	BA_Pop Shuffle1_ES	4/4	1	94			:
GIPI	R&B	1107	MB_R&B Disco_ES	4/4	2	110			Mute Guitar
GIPI	R&B	1108	MC_R&B Disco_ES	4/4	2	110			:
GIPI	R&B	1109	MD_R&B Disco_ES	4/4	2	110			:
GIPI	R&B	1110	FB_R&B Disco_ES	4/4	1	110			:
GIPI	R&B	1111	FC_R&B Disco_ES	4/4	2	110			:
GIPI	R&B	1112	MA_New R&B 2	4/4	1	97			Acoustic Guitar
GIPI	R&B	1113	MB_New R&B 2	4/4	1	123			:
GIPI	R&B	1114	MC_New R&B 2	4/4	1	97			:
GIPI	R&B	1115	IA_New R&B 2_ES	4/4	2	97			:
GIPI	R&B	1116	FA_New R&B 2	4/4	1	97			:
GIPI	R&B	1117	FB_New R&B 2	4/4	1	97			:
GIPI	R&B	1118	MA_New R&B 3	4/4	2	90			:
GIPI	R&B	1119	MB_New R&B 3	4/4	2	90			:
GIPI	R&B	1120	MC_New R&B 3_ES	4/4	2	90			:
GIPI	R&B	1121	MD_New R&B 3	4/4	2	90			:
GIPI	R&B	1122	MA_Pop R&B_XS	4/4	4	67			*Hip-Hop Nylon Guitar*
GIPI	R&B	1123	MB_Pop R&B_XS	4/4	4	67			:
GIPI	R&B	1124	MC_Pop R&B_XS	4/4	4	67			:
GIPI	R&B	1125	FA_Pop R&B_XS	4/4	1	67			:
GIPI	R&B	1126	FB_Pop R&B_XS	4/4	1	67			:
GIPI	R&B	1127	FC_Pop R&B_XS	4/4	1	67			:
GIPI	R&B	1128	MA_H-R&B Pop_XS	4/4	4	140			Acoustic Guitar
GIPI	R&B	1129	MB_H-R&B Pop_XS	4/4	4	140			:
GIPI	R&B	1130	MC_H-R&B Pop_XS	4/4	4	140			:
GIPI	R&B	1131	FA_H-R&B Pop_XS	4/4	1	140			:
GIPI	R&B	1132	MD_6/8 R&B	4/4	2	61			Clean Guitar
GIPI	R&B	1133	FB_6/8 R&B	4/4	1	61			:
GIPI	R&B	1134	FC_6/8 R&B	4/4	1	61			:
GIPI	R&B	1135	MA_Smooth 1	4/4	2	115			Acoustic Guitar
GIPI	R&B	1136	MB_Smooth 1	4/4	2	115			:
GIPI	R&B	1137	MC_Smooth 1	4/4	2	115			:
GIPI	R&B	1138	MD_Smooth 1	4/4	2	115			:
GIPI	R&B	1139	IA_Smooth 1	4/4	1	115			:
GIPI	R&B	1140	FA_Smooth 1	4/4	1	115			:
GIPI	R&B	1141	FB_Smooth 1	4/4	1	115			:
GIPI	R&B	1142	FC_Smooth 1	4/4	2	115			:
GIPI	R&B	1143	BA_Smooth 1	4/4	2	115			:
GIPI	R&B	1144	MA1_Flip Hop 1	4/4	1	132			Clean Guitar
GIPI	R&B	1145	MB1_Flip Hop 1	4/4	2	132			:
GIPI	R&B	1146	MC1_Flip Hop 1	4/4	2	132			Mute Guitar
GIPI	R&B	1147	MD1_Flip Hop 1	4/4	2	132			:
GIPI	R&B	1148	FA1_Flip Hop 1	4/4	1	132			:
GIPI	R&B	1149	FB1_Flip Hop 1	4/4	1	132			:
GIPI	R&B	1150	FA2_Flip Hop 1	4/4	1	132			Acoustic Guitar
GIPI	R&B	1151	FB2_Flip Hop 1_ES	4/4	1	132			:
GIPI	R&B	1152	FC2_Flip Hop 1	4/4	2	132			:
GIPI	R&B	1153	MA_PepRally_ES	4/4	1	75			Clean Guitar
GIPI	R&B	1154	MB_PepR						

Arpeggio Type List

Main Category	Sub Category	ARP No.	ARP Name	Time Signature	Length	Original Tempo	Accent	Random SFX	Voice Type
GIPI	R&B	1157	MA_Hip Hop 2_ES	4/4	2	94			Mute Guitar
GIPI	R&B	1158	MC_Hip Hop 2_ES	4/4	2	94			:
GIPI	R&B	1159	MD_Hip Hop 2_ES	4/4	2	94			:
GIPI	R&B	1160	IA_Hip Hop 2_ES	4/4	2	94			:
GIPI	R&B	1161	MA1_Hip Hop 3	4/4	2	104			Acoustic Guitar
GIPI	R&B	1162	MB1_Hip Hop 3	4/4	2	104			:
GIPI	R&B	1163	MC1_Hip Hop 3	4/4	2	104			:
GIPI	R&B	1164	MD1_Hip Hop 3	4/4	2	104			:
GIPI	R&B	1165	FC1_Hip Hop 3	4/4	2	104			:
GIPI	R&B	1166	MA2_Hip Hop 3_ES	4/4	2	104			Mute Guitar
GIPI	R&B	1167	MB2_Hip Hop 3_ES	4/4	2	104			:
GIPI	R&B	1168	MD2_Hip Hop 3_ES	4/4	2	104			:
GIPI	R&B	1169	FA2_Hip Hop 3_ES	4/4	1	104			:
GIPI	R&B	1170	FC2_Hip Hop 3_ES	4/4	2	104			:
GIPI	R&B	1171	MA1_Hip Hop 6_XS	4/4	4	96			Acoustic Guitar
GIPI	R&B	1172	MB1_Hip Hop 6_XS	4/4	4	96			:
GIPI	R&B	1173	MC1_Hip Hop 6_XS	4/4	4	96			:
GIPI	R&B	1174	FA1_Hip Hop 6_XS	4/4	1	96			:
GIPI	R&B	1175	FB1_Hip Hop 6_XS	4/4	1	96			:
GIPI	R&B	1176	FC1_Hip Hop 6_XS	4/4	1	96			:
GIPI	R&B	1177	BA1_Hip Hop 6_XS	4/4	1	96			:
GIPI	R&B	1178	MA2_Hip Hop 6_XS	4/4	4	96			Od/Dist Guitar
GIPI	R&B	1179	MB2_Hip Hop 6_XS	4/4	4	96			:
GIPI	R&B	1180	MC2_Hip Hop 6_XS	4/4	4	96			:
GIPI	R&B	1181	FA2_Hip Hop 6_XS	4/4	1	96			:
GIPI	R&B	1182	FB2_Hip Hop 6_XS	4/4	1	96			:
GIPI	R&B	1183	FC2_Hip Hop 6_XS	4/4	1	96			:
GIPI	R&B	1184	BA2_Hip Hop 6_XS	4/4	1	96			:
GIPI	R&B	1185	MA_Hip Rock 1_XS	4/4	4	90			:
GIPI	R&B	1186	MB_Hip Rock 1_XS	4/4	4	90			:
GIPI	R&B	1187	MC_Hip Rock 1_XS	4/4	4	90			:
GIPI	R&B	1188	FA_Hip Rock 1_XS	4/4	1	90			:
GIPI	R&B	1189	FB_Hip Rock 1_XS	4/4	1	90			:
GIPI	R&B	1190	FC_Hip Rock 1_XS	4/4	1	90			:
GIPI	R&B	1191	MA_Hip Rock 2_XS	4/4	4	132			:
GIPI	R&B	1192	MB_Hip Rock 2_XS	4/4	4	132			:
GIPI	R&B	1193	MC_Hip Rock 2_XS	4/4	4	132			:
GIPI	R&B	1194	FA_Hip Rock 2_XS	4/4	1	132			:
GIPI	R&B	1195	FB_Hip Rock 2_XS	4/4	1	132			:
GIPI	R&B	1196	FC_Hip Rock 2_XS	4/4	1	132			:
GIPI	R&B	1197	BA_Hip Rock 2_XS	4/4	1	132			:
GIPI	R&B	1198	MB1_ClasichipHop_ES	4/4	2	90			Clean Guitar
GIPI	R&B	1199	MC1_ClasichipHop_ES	4/4	2	90			:
GIPI	R&B	1200	MA2_ClasichipHop	4/4	2	90			:
GIPI	R&B	1201	MB2_ClasichipHop	4/4	2	90			:
GIPI	R&B	1202	MC2_ClasichipHop	4/4	2	90			:
GIPI	R&B	1203	IA2_ClasichipHop	4/4	4	90			:
GIPI	R&B	1204	MD3_ClasichipHop	4/4	2	90			:
GIPI	R&B	1205	FC3_ClasichipHop_ES	4/4	2	90			:
GIPI	R&B	1206	MA_Soul 2	4/4	1	120			:
GIPI	R&B	1207	MB_Soul 2	4/4	1	120			:
GIPI	R&B	1208	MC_Soul 2	4/4	1	120			:
GIPI	R&B	1209	MD_Soul 2	4/4	4	120			:
GIPI	R&B	1210	FC_Soul 2	4/4	4	120			:
GIPI	R&B	1211	MA_New Gospel_ES	4/4	2	90			Mute Guitar
GIPI	R&B	1212	MB_New Gospel_ES	4/4	2	90			:
GIPI	R&B	1213	MC_New Gospel_ES	4/4	2	90			:
GIPI	R&B	1214	MD_New Gospel_ES	4/4	2	90			:
GIPI	R&B	1215	IA_New Gospel_ES	4/4	1	90			:
GIPI	R&B	1216	FA_New Gospel_ES	4/4	1	90			:
GIPI	R&B	1217	FB_New Gospel_ES	4/4	1	90			:
GIPI	R&B	1218	FC_New Gospel_ES	4/4	2	90			:
GIPI	R&B	1219	MA_CleanGuitarA1	4/4	2	120			Clean Guitar
GIPI	R&B	1220	MA_CleanGuitarA2	4/4	2	120			:
GIPI	R&B	1221	MA_CleanGuitarA3	4/4	2	120			:
GIPI	R&B	1222	MA_CleanGuitarA4	4/4	2	120			:
GIPI	R&B	1223	MA_CleanGuitarB1_ES	4/4	4	127			:
GIPI	R&B	1224	MA_CleanGuitarB2_ES	4/4	4	107			:
GIPI	R&B	1225	MA_CleanGuitarB3_ES	4/4	4	107			:
GIPI	R&B	1226	MA_CleanGuitarB4_ES	4/4	4	107			:
GIPI	R&B	1227	MA_CleanGuitarB5_ES	4/4	4	107			:
GIPI	R&B	1228	MA_News1	4/4	2	120			:
GIPI	R&B	1229	MA_News2	4/4	2	120			Mute Guitar
GIPI	R&B	1230	MA_Spanky	4/4	2	105			Clean Guitar
GIPI	Elect	1231	MA1_Chill Out	4/4	2	79			:
GIPI	Elect	1232	MA2_Chill Out	4/4	1	79			Acoustic Guitar
GIPI	Elect	1233	MB2_Chill Out	4/4	2	79			:
GIPI	Elect	1234	MC2_Chill Out	4/4	2	79			:
GIPI	Elect	1235	MD2_Chill Out	4/4	2	79			:
GIPI	Elect	1236	MA_Big Beat 1_ES	4/4	4	115			Od/Dist Guitar
GIPI	Elect	1237	MB_Big Beat 1_ES	4/4	4	115			:
GIPI	Elect	1238	MC_Big Beat 1_ES	4/4	4	115			:
GIPI	Elect	1239	FA_Big Beat 1_ES	4/4	1	115			:

Main Category	Sub Category	ARP No.	ARP Name	Time Signature	Length	Original Tempo	Accent	Random SFX	Voice Type
GIPI	Elect	1240	FB_Big Beat 1_ES	4/4	1	115			Od/Dist Guitar
GIPI	Elect	1241	FC_Big Beat 1_ES	4/4	1	115			:
GIPI	Elect	1242	BA_Big Beat 1_ES	4/4	1	115			:
GIPI	Elect	1243	MA_Big Beat 2_ES	4/4	4	145			:
GIPI	Elect	1244	MB_Big Beat 2_ES	4/4	8	145			:
GIPI	Elect	1245	MC_Big Beat 2_ES	4/4	4	145			:
GIPI	Elect	1246	FA_Big Beat 2_ES	4/4	1	145			:
GIPI	Elect	1247	FB_Big Beat 2_ES	4/4	1	145			:
GIPI	Elect	1248	FC_Big Beat 2_ES	4/4	1	145			:
GIPI	Elect	1249	BA_Big Beat 2_ES	4/4	2	145			:
GIPI	Elect	1250	MA1_Retro Pop_ES	4/4	2	126			Acoustic Guitar
GIPI	Elect	1251	MA2_Retro Pop_ES	4/4	2	126			Clean Guitar
GIPI	Elect	1252	MA_Disco House	4/4	2	128			:
GIPI	Elect	1253	MB_Disco House	4/4	2	128			:
GIPI	Elect	1254	MC_Disco House	4/4	2	128			:
GIPI	Elect	1255	MD_Disco House	4/4	2	128			:
GIPI	Elect	1256	IA_Disco House	4/4	4	128			:
GIPI	Elect	1257	FA_Disco House	4/4	1	128			:
GIPI	Elect	1258	FB_Disco House	4/4	1	128			:
GIPI	Elect	1259	FC_Disco House	4/4	4	128			:
GIPI	Jazz	1260	MA_AcousticJazz_ES	4/4	4	204			:
GIPI	Jazz	1261	MB_AcousticJazz_ES	4/4	4	204			:
GIPI	Jazz	1262	MC_AcousticJazz_ES	4/4	4	204			:
GIPI	Jazz	1263	MD_AcousticJazz_ES	4/4	4	204			:
GIPI	Jazz	1264	IA_AcousticJazz_ES	4/4	4	204			:
GIPI	Jazz	1265	FA_AcousticJazz_ES	4/4	1	204			:
GIPI	Jazz	1266	FB_AcousticJazz_ES	4/4	1	204			:
GIPI	Jazz	1267	FC_AcousticJazz_ES	4/4	4	204			:
GIPI	Jazz	1268	MA_Modern Jazz_XS	4/4	16	218			:
GIPI	Jazz	1269	MB_Modern Jazz_XS	4/4	16	218			:
GIPI	Jazz	1270	MC_Modern Jazz_XS	4/4	16	218			:
GIPI	Jazz	1271	FA_Modern Jazz_XS	4/4	1	218			:
GIPI	Jazz	1272	FB_Modern Jazz_XS	4/4	1	218			:
GIPI	Jazz	1273	FC_Modern Jazz_XS	4/4	1	218			:
GIPI	Jazz	1274	BA_Modern Jazz_XS	4/4	1	218			:
GIPI	Jazz	1275	MA_R&R Shuffle_XS	4/4	4	192			:
GIPI	Jazz	1276	MB_R&R Shuffle_XS	4/4	4	192			:
GIPI	Jazz	1277	MC_R&R Shuffle_XS	4/4	4	192			:
GIPI	Jazz	1278	FA_R&R Shuffle_XS	4/4	1	192			:
GIPI	Jazz	1279	FB_R&R Shuffle_XS	4/4	1	192			:
GIPI	Jazz	1280	FC_R&R Shuffle_XS	4/4	1	192			:
GIPI	Jazz	1281	BA_R&R Shuffle_XS	4/4	1	192			:
GIPI	Jazz	1282	MA_Slow Blues 2_XS	4/4	4	72			"Mid Drive (2handGtr)"
GIPI	Jazz	1283	MB_Slow Blues 2_XS	4/4	4	72			:
GIPI	Jazz	1284	MC_Slow Blues 2_XS	4/4	4	72			:
GIPI	Jazz	1285	FA_Slow Blues 2_XS	4/4	1	72			:
GIPI	Jazz	1286	FB_Slow Blues 2_XS	4/4	1	72			:
GIPI	Jazz	1287	FC_Slow Blues 2_XS	4/4	1	72			:
GIPI	Jazz	1288	BA_Slow Blues 2_XS	4/4	1	72			:
GIPI	Jazz	1289	MA_Slow Blues 2_ES	4/4	4	72			:
GIPI	Jazz	1290	MB_Slow Blues 2_ES	4/4	4	72			:
GIPI	Jazz	1291	MC_Slow Blues 2_ES	4/4	4	72			:
GIPI	Jazz	1292	FA_Slow Blues 2_ES	4/4	1	72			:
GIPI	Jazz	1293	FB_Slow Blues 2_ES	4/4	1	72			:
GIPI	Jazz	1294	FC_Slow Blues 2_ES	4/4	1	72			:
GIPI	Jazz	1295	BA_Slow Blues 2_ES	4/4	1	72			:
GIPI	World	1296	MA1_Reggae 1	4/4	1	102			Clean Guitar
GIPI	World	1297	MB1_Reggae 1	4/4	2	102			:
GIPI	World	1298	MD1_Reggae 1	4/4	2	90			:
GIPI	World	1299	IA1_Reggae 1	4/4	1	102			:
GIPI	World	1300	FC1_Reggae 1	4/4	2	96			:
GIPI	World	1301	MA2_Reggae 1	4/4	4	102			Mute Guitar
GIPI	World	1302	MB2_Reggae 1	4/4	4	102			:
GIPI	World	1303	MA_Reggae 2	4/4	2	92			Clean Guitar
GIPI	World	1304	MB_Reggae 2	4/4	1	92			:
GIPI	World	1305	IA_Reggae 2	4/4	2	92			:
GIPI	World	1306	MA_Montuno_ES	4/4	2	100			Acoustic Guitar
GIPI	World	1307	MB_Montuno_ES	4/4	2	100			:
GIPI	World	1308	MC_Montuno/1_ES	4/4	2	100			:
GIPI	World	1309	MD_Montuno/2_ES	4/4	4	100			:
GIPI	World	1310	IA_Montuno/1_ES	4/4	2	100			:
GIPI	World	1311	MD_Montuno/2_ES	4/4	2	100			:
GIPI	World	1312	IA_Montuno_ES	4/4	2	100			:
GIPI	World	1313	FA_Montuno_ES	4/4	1	100			:
GIPI	World	1314	FC_Montuno_ES	4/4	1	100			:
GIPI	World	1315	MA_Samba	4/4	4	120			:
GIPI	World	1316	MB_Samba	4/4	4	120			:
GIPI	World	1317	MD_Samba	4/4	4	120			:
GIPI	World	1318	IA_Samba	4/4	2	120			:
GIPI	World	1319	MA_Bomba_XS	4/4	4	99			:
GIPI	World	1320	MB_Bomba_XS	4/4	4	99			

Arpeggio Type List

Main Category	Sub Category	ARP No.	ARP Name	Time Signature	Length	Original Tempo	Accent	Random SFX	Voice Type
GIPI	World	1323	FB_Bomba_XS	4/4	1	99			Acoustic Guitar
GIPI	World	1324	FC_Bomba_XS	4/4	1	99			:
GIPI	World	1325	BA_Bomba_XS	4/4	1	99			:
GIPI	World	1326	MA_Bomba_ES	4/4	4	99			:
GIPI	World	1327	MB_Bomba	4/4	4	99			:
GIPI	World	1328	MC_Bomba_ES	4/4	4	99			:
GIPI	World	1329	FA_Bomba	4/4	1	99			:
GIPI	World	1330	FB_Bomba	4/4	1	99			:
GIPI	World	1331	FC_Bomba_ES	4/4	1	99			:
GIPI	World	1332	BA_Bomba	4/4	1	99			:
GIPI	World	1333	MA_Guaguanco_XS	4/4	4	120			:
GIPI	World	1334	MB_Guaguanco_XS	4/4	4	120			:
GIPI	World	1335	MC_Guaguanco_XS	4/4	4	120			:
GIPI	World	1336	FA_Guaguanco_XS	4/4	1	120			:
GIPI	World	1337	FB_Guaguanco_XS	4/4	1	120			:
GIPI	World	1338	FC_Guaguanco_XS	4/4	1	120			:
GIPI	World	1339	BA_Guaguanco_XS	4/4	1	120			:
GIPI	World	1340	MC1_Latin Rock	4/4	2	120			Clean Guitar
GIPI	World	1341	FB1_Latin Rock	4/4	1	120			:
GIPI	World	1342	MB2_Latin Rock	4/4	1	120			Acoustic Guitar
GIPI	World	1343	MC2_Latin Rock	4/4	2	120			:
GIPI	World	1344	MA_LatinPhrase1	4/4	2	120			:
GIPI	World	1345	MA_LatinPhrase2	4/4	2	120			:
GIPI	World	1346	MA_LatinPhrase3	4/4	1	120			:
GIPI	World	1347	MA_SteelGuitar1_ES	4/4	4	120			:
GIPI	World	1348	MA_SteelGuitar2_ES	4/4	4	120			:
GIPI	World	1349	MA_SteelGuitar3_ES	4/4	4	120			:
GIPI	World	1350	MA_SteelGuitar4_ES	4/4	4	120			:
GIPI	World	1351	MA1_Spanish Pop	4/4	2	120			:
GIPI	World	1352	MB1_Spanish Pop	4/4	2	120			:
GIPI	World	1353	MD1_Spanish Pop	4/4	2	120			:
GIPI	World	1354	FA1_Spanish Pop	4/4	1	120			:
GIPI	World	1355	FB1_Spanish Pop	4/4	1	120			:
GIPI	World	1356	IA2_Spanish Pop	4/4	4	120			:
GIPI	World	1357	FC2_Spanish Pop	4/4	3	120			:
GIPI	World	1358	MA3_Spanish Pop	4/4	2	120			:
GIPI	World	1359	MB3_Spanish Pop	4/4	2	120			:
GIPI	World	1360	MC3_Spanish Pop	4/4	2	120			:
GIPI	World	1361	MD3_Spanish Pop	4/4	2	120			:
GIPI	World	1362	IA3_Spanish Pop	4/4	4	120			:
GIPI	World	1363	FA3_Spanish Pop	4/4	1	120			:
GIPI	World	1364	FB3_Spanish Pop	4/4	1	120			:
GIPI	World	1365	MB1_Turkish_ES	4/4	2	105			Kotoun
GIPI	World	1366	MD1_Turkish_ES	9/8	2	125			:
GIPI	World	1367	ME1_Turkish_ES	4/4	2	105			:
GIPI	World	1368	IA1_Turkish_ES	4/4	2	86			:
GIPI	World	1369	MF2_Turkish_ES	4/4	2	105			Kanun
GIPI	World	1370	MA3_Turkish_ES	4/4	2	105			Bouzuki
GIPI	Genrl	1371	MA_Strum1	4/4	1	120			Acoustic Guitar
GIPI	Genrl	1372	MA_Strum2	4/4	2	120			:
GIPI	Genrl	1373	MA_Strum3	4/4	4	120			:
GIPI	Genrl	1374	MA_Strum4	4/4	2	120			:
GIPI	Genrl	1375	MA_Strum5	4/4	2	120			:
GIPI	Genrl	1376	MA_Strum6	4/4	2	120			:
GIPI	Genrl	1377	MA_Strum7	4/4	2	120			:
GIPI	Genrl	1378	MA_Strum8	4/4	2	120			:
GIPI	Genrl	1379	MA_Strum9	4/4	2	120			:
GIPI	Genrl	1380	MA_Strum10	4/4	2	120			:
GIPI	Genrl	1381	MA_Guitar Arp1	4/4	1	120			:
GIPI	Genrl	1382	MA_Guitar Arp2	4/4	1	120			:
GIPI	Genrl	1383	MA_Guitar Arp3	4/4	1	120			:
GIPI	Genrl	1384	MA_Guitar Arp4	4/4	1	120			:
GIPI	Genrl	1385	MA_RollIArp	4/4	4	60			:
GIPI	Genrl	1386	Tremolo	4/4	1	100			:
GIPI	Genrl	1387	Lick1	4/4	4	120			Od/Dist Guitar
GIPI	Genrl	1388	Lick2	4/4	4	120			:
GIPI	Genrl	1389	Lick3	4/4	4	120			:
GIPI	Genrl	1390	Lick4	4/4	2	120			:
GIPI	Genrl	1391	Lick5	4/4	4	120			:
GIPI	Genrl	1392	Lick6	4/4	1	120			:
GIMG	Rock	1393	MA1_StandardRock_XS	4/4	4	131		○	"Mega 60s Tube Tone"
GIMG	Rock	1394	MB1_StandardRock_XS	4/4	4	131		○	:
GIMG	Rock	1395	MC1_StandardRock_XS	4/4	4	131		○	:
GIMG	Rock	1396	FA1_StandardRock_XS	4/4	1	131		○	:
GIMG	Rock	1397	FB1_StandardRock_XS	4/4	1	131		○	:
GIMG	Rock	1398	FC1_StandardRock_XS	4/4	1	131		○	:
GIMG	Rock	1399	BA1_StandardRock_XS	4/4	1	131		○	:
GIMG	Rock	1400	MA2_StandardRock_XS	4/4	4	131		○	"Mega 1coil Slap Dist"
GIMG	Rock	1401	MB2_StandardRock_XS	4/4	4	131		○	:
GIMG	Rock	1402	MC2_StandardRock_XS	4/4	4	131		○	:
GIMG	Rock	1403	FA2_StandardRock_XS	4/4	1	131		○	:
GIMG	Rock	1404	FB2_StandardRock_XS	4/4	1	131		○	:
GIMG	Rock	1405	FC2_StandardRock_XS	4/4	1	131		○	:

Main Category	Sub Category	ARP No.	ARP Name	Time Signature	Length	Original Tempo	Accent	Random SFX	Voice Type
GIMG	Rock	1406	BA2_StandardRock_XS	4/4	1	131		○	"Mega 1coil Slap Dist"
GIMG	Rock	1407	MA1_Ovdr PowerRk_XS	4/4	4	120		○	"Mega Ovdr Distortion"
GIMG	Rock	1408	MB1_Ovdr PowerRk_XS	4/4	4	120		○	:
GIMG	Rock	1409	MC1_Ovdr PowerRk_XS	4/4	4	120		○	:
GIMG	Rock	1410	FA1_Ovdr PowerRk_XS	4/4	1	120		○	:
GIMG	Rock	1411	FB1_Ovdr PowerRk_XS	4/4	1	120		○	:
GIMG	Rock	1412	FC1_Ovdr PowerRk_XS	4/4	1	120		○	:
GIMG	Rock	1413	BA1_Ovdr PowerRk_XS	4/4	1	120		○	:
GIMG	Rock	1414	MA1_Ovdr PowerRk	4/4	4	120		○	:
GIMG	Rock	1415	MB1_Ovdr PowerRk	4/4	4	120		○	:
GIMG	Rock	1416	MC1_Ovdr PowerRk	4/4	4	120		○	:
GIMG	Rock	1417	FA1_Ovdr PowerRk	4/4	1	120		○	:
GIMG	Rock	1418	FB1_Ovdr PowerRk	4/4	1	120		○	:
GIMG	Rock	1419	FC1_Ovdr PowerRk	4/4	1	120		○	:
GIMG	Rock	1420	BA1_Ovdr PowerRk	4/4	1	120		○	:
GIMG	Rock	1421	MA2_Ovdr PowerRk_XS	4/4	4	120		○	"Mega Ovdr Fuzz"
GIMG	Rock	1422	MB2_Ovdr PowerRk_XS	4/4	4	120		○	:
GIMG	Rock	1423	MC2_Ovdr PowerRk_XS	4/4	4	120		○	:
GIMG	Rock	1424	FA2_Ovdr PowerRk_XS	4/4	1	120		○	:
GIMG	Rock	1425	FB2_Ovdr PowerRk_XS	4/4	1	120		○	:
GIMG	Rock	1426	FC2_Ovdr PowerRk_XS	4/4	1	120		○	:
GIMG	Rock	1427	BA2_Ovdr PowerRk_XS	4/4	1	120		○	:
GIMG	Rock	1428	MA2_Ovdr PowerRk	4/4	4	120		○	:
GIMG	Rock	1429	MB2_Ovdr PowerRk	4/4	4	120		○	:
GIMG	Rock	1430	MC2_Ovdr PowerRk	4/4	4	120		○	:
GIMG	Rock	1431	FA2_Ovdr PowerRk	4/4	1	120		○	:
GIMG	Rock	1432	FB2_Ovdr PowerRk	4/4	1	120		○	:
GIMG	Rock	1433	FC2_Ovdr PowerRk	4/4	1	120		○	:
GIMG	Rock	1434	BA2_Ovdr PowerRk	4/4	1	120		○	:
GIMG	Rock	1435	MA_ContempRock_XS	4/4	4	126		○	"Mega 1coil Slap Dist"
GIMG	Rock	1436	MB_ContempRock_XS	4/4	4	126		○	:
GIMG	Rock	1437	MC_ContempRock_XS	4/4	4	126		○	:
GIMG	Rock	1438	FA_ContempRock_XS	4/4	1	126		○	:
GIMG	Rock	1439	FB_ContempRock_XS	4/4	1	126		○	:
GIMG	Rock	1440	FC_ContempRock_XS	4/4	1	126		○	:
GIMG	Rock	1441	BA_ContempRock_XS	4/4	1	126		○	:
GIMG	Rock	1442	MA1_Hard Rock_XS	4/4	4	120		○	"Mega 60s Tube Tone"
GIMG	Rock	1443	MB1_Hard Rock_XS	4/4	4	120		○	:
GIMG	Rock	1444	MC1_Hard Rock_XS	4/4	4	120		○	:
GIMG	Rock	1445	FA1_Hard Rock_XS	4/4	1	120		○	:
GIMG	Rock	1446	FB1_Hard Rock_XS	4/4	1	120		○	:
GIMG	Rock	1447	FC1_Hard Rock_XS	4/4	1	120		○	:
GIMG	Rock	1448	BA1_Hard Rock_XS	4/4	1	120		○	:
GIMG	Rock	1449	MA2_Hard Rock_XS	4/4	4	120		○	:
GIMG	Rock	1450	MB2_Hard Rock_XS	4/4	4	120		○	:
GIMG	Rock	1451	MC2_Hard Rock_XS	4/4	4	120		○	:
GIMG	Rock	1452	FA2_Hard Rock_XS	4/4	1	120		○	:
GIMG	Rock	1453	FB2_Hard Rock_XS	4/4	1	120		○	:
GIMG	Rock	1454	FC2_Hard Rock_XS	4/4	1	120		○	:
GIMG	Rock	1455	BA2_Hard Rock_XS	4/4	1	120		○	:
GIMG	Rock	1456	MA1_Blues Rock_XS	4/4	4	120		○	"Mega 60s Dist Stack"
GIMG	Rock	1457	MB1_Blues Rock_XS	4/4	4	120		○	:
GIMG	Rock	1458	MC1_Blues Rock_XS	4/4	4	120		○	:
GIMG	Rock	1459	FA1_Blues Rock_XS	4/4	1	120		○	:
GIMG	Rock	1460	FB1_Blues Rock_XS	4/4	1	120		○	:
GIMG	Rock	1461	FC1_Blues Rock_XS	4/4	1	120		○	:
GIMG	Rock	1462	BA1_Blues Rock_XS	4/4	1	120		○	:
GIMG	Rock	1463	MA2_Blues Rock_XS	4/4	4	120		○	"Mega 60s Tube Tone"
GIMG	Rock	1464	MB2_Blues Rock_XS	4/4	4	120		○	:
GIMG	Rock	1465	MC2_Blues Rock_XS	4/4	4	120		○	:
GIMG	Rock	1466	FA2_Blues Rock_XS	4/4	1	120		○	:
GIMG	Rock	1467	FB2_Blues Rock_XS	4/4	1	120		○	:
GIMG	Rock	1468	FC2_Blues Rock_XS	4/4	1	120		○	:
GIMG	Rock	1469	BA2_Blues Rock_XS	4/4	1	120		○	:
GIMG	Rock	1470	MA_Rock & Roll_XS	4/4	4	172		○	"Mega 60s Clean"
GIMG	Rock	1471	MB_Rock & Roll_XS	4/4	4	172		○	:
GIMG	Rock	1472	MC_Rock & Roll_XS	4/4	4	172		○	:
GIMG	Rock	1473	FA_Rock & Roll_XS	4/4	1	172		○	:
GIMG	Rock	1474	FB_Rock & Roll_XS	4/4	1	172		○	:
GIMG	Rock	1475	FC_Rock & Roll_XS	4/4	1	172		○	:
GIMG	Rock	1476	BA_Rock & Roll_XS	4/4	1	172		○	:
GIMG	Rock	1477	MA_Guitar Pop 1_XS	4/4	4	100		○	"Mega 60s ChorusCombo"
GIMG	Rock	1478	MB_Guitar Pop 1_XS	4/4	4	100		○	:
GIMG	Rock	1479	MC_Guitar Pop 1_XS	4/4	4	100		○	:
GIMG	Rock	1480	FA_Guitar Pop 1_XS	4/4	1	100		○	:
GIMG	Rock	1481	FB_Guitar Pop 1_XS	4/4	1	100		○	:
GIMG	Rock	1482	FC_Guitar Pop 1_XS	4/4	1	100		○	:
GIMG	Rock	1483	BA_Guitar Pop 1_XS	4/4	1	100		○	:
GIMG	Rock	1484	MA1_Acoustic Pop_XS	4/4	4	110		○	"Mega Steel"
GIMG	Rock	1485	MB1_Acoustic Pop_XS	4/4	4	110			

Arpeggio Type List

Main Category	Sub Category	ARP No.	ARP Name	Time Signature	Length	Original Tempo	Accent	Random SFX	Voice Type
GIMG	Rock	1489	FC1_Acoustic Pop_XS	4/4	1	110		○	"Mega Steel"
GIMG	Rock	1490	MA2_Acoustic Pop_XS	4/4	4	110		○	"Mega 60s Clean"
GIMG	Rock	1491	MB2_Acoustic Pop_XS	4/4	4	110		○	:
GIMG	Rock	1492	MC2_Acoustic Pop_XS	4/4	4	110		○	:
GIMG	Rock	1493	FA2_Acoustic Pop_XS	4/4	1	110		○	:
GIMG	Rock	1494	FB2_Acoustic Pop_XS	4/4	1	110		○	:
GIMG	Rock	1495	FC2_Acoustic Pop_XS	4/4	1	110		○	:
GIMG	Rock	1496	MA1_GuitarBallad_XS	4/4	8	94		○	"Mega Steel"
GIMG	Rock	1497	MB1_GuitarBallad_XS	4/4	8	94		○	:
GIMG	Rock	1498	MC1_GuitarBallad_XS	4/4	8	94		○	:
GIMG	Rock	1499	FA1_GuitarBallad_XS	4/4	1	94		○	:
GIMG	Rock	1500	FB1_GuitarBallad_XS	4/4	1	94		○	:
GIMG	Rock	1501	FC1_GuitarBallad_XS	4/4	1	94		○	:
GIMG	Rock	1502	BA1_GuitarBallad_XS	4/4	1	94		○	:
GIMG	Rock	1503	MA1_GuitarBallad	4/4	8	94		○	:
GIMG	Rock	1504	MB1_GuitarBallad	4/4	8	94		○	:
GIMG	Rock	1505	MC1_GuitarBallad	4/4	8	94		○	:
GIMG	Rock	1506	FA1_GuitarBallad	4/4	1	94		○	:
GIMG	Rock	1507	FB1_GuitarBallad	4/4	1	94		○	:
GIMG	Rock	1508	FC1_GuitarBallad	4/4	1	94		○	:
GIMG	Rock	1509	BA1_GuitarBallad	4/4	1	94		○	:
GIMG	Rock	1510	MA2_GuitarBallad_XS	4/4	8	94		○	"Mega Nylon"
GIMG	Rock	1511	MB2_GuitarBallad_XS	4/4	8	94		○	:
GIMG	Rock	1512	MC2_GuitarBallad_XS	4/4	8	94		○	:
GIMG	Rock	1513	FA2_GuitarBallad_XS	4/4	1	94		○	:
GIMG	Rock	1514	FB2_GuitarBallad_XS	4/4	1	94		○	:
GIMG	Rock	1515	FC2_GuitarBallad_XS	4/4	1	94		○	:
GIMG	Rock	1516	BA2_GuitarBallad_XS	4/4	1	94		○	:
GIMG	Rock	1517	MA2_GuitarBallad	4/4	8	94		○	:
GIMG	Rock	1518	MB2_GuitarBallad	4/4	8	94		○	:
GIMG	Rock	1519	MC2_GuitarBallad	4/4	8	94		○	:
GIMG	Rock	1520	FA2_GuitarBallad	4/4	1	94		○	:
GIMG	Rock	1521	FB2_GuitarBallad	4/4	1	94		○	:
GIMG	Rock	1522	FC2_GuitarBallad	4/4	1	94		○	:
GIMG	Rock	1523	BA2_GuitarBallad	4/4	1	94		○	:
GIMG	Rock	1524	MA_Unplugged 1_XS	4/4	4	120		○	"Mega Steel"
GIMG	Rock	1525	MB_Unplugged 1_XS	4/4	4	120		○	:
GIMG	Rock	1526	MC_Unplugged 1_XS	4/4	4	120		○	:
GIMG	Rock	1527	FA_Unplugged 1_XS	4/4	1	120		○	:
GIMG	Rock	1528	FB_Unplugged 1_XS	4/4	1	120		○	:
GIMG	Rock	1529	FC_Unplugged 1_XS	4/4	1	120		○	:
GIMG	Rock	1530	BA_Unplugged 1_XS	4/4	1	120		○	:
GIMG	Rock	1531	MA_Unplugged 1	4/4	4	120		○	:
GIMG	Rock	1532	MB_Unplugged 1	4/4	4	120		○	:
GIMG	Rock	1533	MC_Unplugged 1	4/4	4	120		○	:
GIMG	Rock	1534	FA_Unplugged 1	4/4	1	120		○	:
GIMG	Rock	1535	FB_Unplugged 1	4/4	1	120		○	:
GIMG	Rock	1536	FC_Unplugged 1	4/4	1	120		○	:
GIMG	Rock	1537	BA_Unplugged 1	4/4	1	120		○	:
GIMG	Rock	1538	MA_Unplugged 2_XS	4/4	8	120		○	:
GIMG	Rock	1539	MB_Unplugged 2_XS	4/4	8	120		○	:
GIMG	Rock	1540	MC_Unplugged 2_XS	4/4	8	120		○	:
GIMG	Rock	1541	FA_Unplugged 2_XS	4/4	1	120		○	:
GIMG	Rock	1542	FB_Unplugged 2_XS	4/4	1	120		○	:
GIMG	Rock	1543	FC_Unplugged 2_XS	4/4	1	120		○	:
GIMG	Rock	1544	BA_Unplugged 2_XS	4/4	1	120		○	:
GIMG	Rock	1545	MA_Unplugged 2	4/4	8	120		○	:
GIMG	Rock	1546	MB_Unplugged 2	4/4	8	120		○	:
GIMG	Rock	1547	MC_Unplugged 2	4/4	8	120		○	:
GIMG	Rock	1548	FA_Unplugged 2	4/4	1	120		○	:
GIMG	Rock	1549	FB_Unplugged 2	4/4	1	120		○	:
GIMG	Rock	1550	FC_Unplugged 2	4/4	1	120		○	:
GIMG	Rock	1551	BA_Unplugged 2	4/4	1	120		○	:
GIMG	Rock	1552	MA1_Worship Slow_XS	4/4	4	75		○	:
GIMG	Rock	1553	MB1_Worship Slow_XS	4/4	4	75		○	:
GIMG	Rock	1554	MC1_Worship Slow_XS	4/4	4	75		○	:
GIMG	Rock	1555	FA1_Worship Slow_XS	4/4	1	75		○	:
GIMG	Rock	1556	FB1_Worship Slow_XS	4/4	1	75		○	:
GIMG	Rock	1557	FC1_Worship Slow_XS	4/4	1	75		○	:
GIMG	Rock	1558	BA1_Worship Slow_XS	4/4	1	75		○	:
GIMG	Rock	1559	MA2_Worship Slow_XS	4/4	4	75		○	"Mega Nylon"
GIMG	Rock	1560	MB2_Worship Slow_XS	4/4	4	75		○	:
GIMG	Rock	1561	MC2_Worship Slow_XS	4/4	4	75		○	:
GIMG	Rock	1562	FA2_Worship Slow_XS	4/4	1	75		○	:
GIMG	Rock	1563	FB2_Worship Slow_XS	4/4	1	75		○	:
GIMG	Rock	1564	FC2_Worship Slow_XS	4/4	1	75		○	:
GIMG	Rock	1565	BA2_Worship Slow_XS	4/4	1	75		○	:
GIMG	Rock	1566	MA1_Worship Med_XS	4/4	8	140		○	"Mega Steel"
GIMG	Rock	1567	MB1_Worship Med_XS	4/4	4	140		○	:
GIMG	Rock	1568	MC1_Worship Med_XS	4/4	4	140		○	:
GIMG	Rock	1569	FA1_Worship Med_XS	4/4	1	140		○	:
GIMG	Rock	1570	FB1_Worship Med_XS	4/4	1	140		○	:
GIMG	Rock	1571	FC1_Worship Med_XS	4/4	1	140		○	:

Main Category	Sub Category	ARP No.	ARP Name	Time Signature	Length	Original Tempo	Accent	Random SFX	Voice Type
GIMG	Rock	1572	BA1_Worship Med_XS	4/4	1	140		○	"Mega Steel"
GIMG	Rock	1573	MA2_Worship Med_XS	4/4	8	140		○	"Mega Nylon"
GIMG	Rock	1574	MB2_Worship Med_XS	4/4	4	140		○	:
GIMG	Rock	1575	MC2_Worship Med_XS	4/4	4	140		○	:
GIMG	Rock	1576	FA2_Worship Med_XS	4/4	1	140		○	:
GIMG	Rock	1577	FB2_Worship Med_XS	4/4	1	140		○	:
GIMG	Rock	1578	FC2_Worship Med_XS	4/4	1	140		○	:
GIMG	Rock	1579	BA2_Worship Med_XS	4/4	1	140		○	:
GIMG	Rock	1580	MA_Worship Fast_XS	4/4	8	114		○	"Mega Steel"
GIMG	Rock	1581	MB_Worship Fast_XS	4/4	4	114		○	:
GIMG	Rock	1582	MC_Worship Fast_XS	4/4	4	114		○	:
GIMG	Rock	1583	FA_Worship Fast_XS	4/4	1	114		○	:
GIMG	Rock	1584	FB_Worship Fast_XS	4/4	1	114		○	:
GIMG	Rock	1585	FC_Worship Fast_XS	4/4	1	114		○	:
GIMG	Rock	1586	BA_Worship Fast_XS	4/4	1	114		○	:
GIMG	Rock	1587	MA_New Country_XS	4/4	2	118		○	"Mega 60s Clean"
GIMG	Rock	1588	MB_New Country_XS	4/4	4	118		○	:
GIMG	Rock	1589	MC_New Country_XS	4/4	2	118		○	:
GIMG	Rock	1590	FA_New Country_XS	4/4	1	118		○	:
GIMG	Rock	1591	FB_New Country_XS	4/4	1	118		○	:
GIMG	Rock	1592	FC_New Country_XS	4/4	1	118		○	:
GIMG	Rock	1593	BA_New Country_XS	4/4	1	118		○	:
GIMG	Rock	1594	MA_New Country	4/4	2	118		○	:
GIMG	Rock	1595	MB_New Country	4/4	4	118		○	:
GIMG	Rock	1596	MC_New Country	4/4	2	118		○	:
GIMG	Rock	1597	FA_New Country	4/4	1	118		○	:
GIMG	Rock	1598	FB_New Country	4/4	1	118		○	:
GIMG	Rock	1599	FC_New Country	4/4	1	118		○	:
GIMG	Rock	1600	BA_New Country	4/4	1	118		○	:
GIMG	Rock	1601	MA1_VintageGiPop_XS	4/4	4	148		○	"Mega Steel"
GIMG	Rock	1602	MB1_VintageGiPop_XS	4/4	4	148		○	:
GIMG	Rock	1603	MC1_VintageGiPop_XS	4/4	4	148		○	:
GIMG	Rock	1604	FA1_VintageGiPop_XS	4/4	1	148		○	:
GIMG	Rock	1605	FB1_VintageGiPop_XS	4/4	1	148		○	:
GIMG	Rock	1606	FC1_VintageGiPop_XS	4/4	1	148		○	:
GIMG	Rock	1607	BA1_VintageGiPop_XS	4/4	1	148		○	:
GIMG	Rock	1608	MA2_VintageGiPop_XS	4/4	4	148		○	"Mega 60s Clean"
GIMG	Rock	1609	MB2_VintageGiPop_XS	4/4	4	148		○	:
GIMG	Rock	1610	MC2_VintageGiPop_XS	4/4	4	148		○	:
GIMG	Rock	1611	FA2_VintageGiPop_XS	4/4	1	148		○	:
GIMG	Rock	1612	FB2_VintageGiPop_XS	4/4	1	148		○	:
GIMG	Rock	1613	FC2_VintageGiPop_XS	4/4	1	148		○	:
GIMG	Rock	1614	BA2_VintageGiPop_XS	4/4	1	148		○	:
GIMG	Rock	1615	MA1_WestCoastPop_XS	4/4	4	100		○	"Mega Steel"
GIMG	Rock	1616	MB1_WestCoastPop_XS	4/4	4	100		○	:
GIMG	Rock	1617	MC1_WestCoastPop_XS	4/4	4	100		○	:
GIMG	Rock	1618	FA1_WestCoastPop_XS	4/4	1	100		○	:
GIMG	Rock	1619	FB1_WestCoastPop_XS	4/4	1	100		○	:
GIMG	Rock	1620	FC1_WestCoastPop_XS	4/4	1	100		○	:
GIMG	Rock	1621	BA1_WestCoastPop_XS	4/4	1	100		○	:
GIMG	Rock	1622	MA2_WestCoastPop_XS	4/4	4	100		○	"Mega 60s Tube Tone"
GIMG	Rock	1623	MB2_WestCoastPop_XS	4/4	4	100		○	:
GIMG	Rock	1624	MC2_WestCoastPop_XS	4/4	4	100		○	:
GIMG	Rock	1625	FA2_WestCoastPop_XS	4/4	1	100		○	:
GIMG	Rock	1626	FB2_WestCoastPop_XS	4/4	1	100		○	:
GIMG	Rock	1627	FC2_WestCoastPop_XS	4/4	1	100		○	:
GIMG	Rock	1628	BA2_WestCoastPop_XS	4/4	1	100		○	:
GIMG	Rock	1629	MA1_Brit Pop_XS	4/4	2	86		○	"Mega Steel"
GIMG	Rock	1630	MB1_Brit Pop_XS	4/4	2	86		○	:
GIMG	Rock	1631	MC1_Brit Pop_XS	4/4	2	86		○	:
GIMG	Rock	1632	FA1_Brit Pop_XS	4/4	1	86		○	:
GIMG	Rock	1633	FB1_Brit Pop_XS	4/4	1	86		○	:
GIMG	Rock	1634	FC1_Brit Pop_XS	4/4	1	86		○	:
GIMG	Rock	1635	BA1_Brit Pop_XS	4/4	1	86		○	:
GIMG	Rock	1636	MA1_Brit Pop	4/4	2	86		○	:
GIMG	Rock	1637	MB1_Brit Pop	4/4	2	86		○	:
GIMG	Rock	1638	MC1_Brit Pop	4/4	2	86		○	:
GIMG	Rock	1639	FA1_Brit Pop	4/4	1	86		○	:
GIMG	Rock	1640	FB1_Brit Pop	4/4	1	86		○	:
GIMG	Rock	1641	FC1_Brit Pop	4/4	1	86		○	:
GIMG	Rock	1642	BA1_Brit Pop	4/4	1	86		○	:
GIMG	Rock	1643	MA2_Brit Pop_XS	4/4	2	86		○	"Mega 1coil SlapClean"
GIMG	Rock	1644	MB2_Brit Pop_XS	4/4	2	86		○	:
GIMG	Rock	1645	MC2_Brit Pop_XS	4/4	2	86		○	:
GIMG	Rock	1646	FA2_Brit Pop_XS	4/4	1	86		○	:
GIMG	Rock	1647	FB2_Brit Pop_XS	4/4	1	86		○	:
GIMG	Rock	1648	FC2_Brit Pop_XS	4/4	1	86		○	:
GIMG	Rock	1649	BA2_Brit Pop_XS	4/4	1	86		○	:
GIMG	Rock	1650	MA2_Brit Pop	4/4	2	86		○	:
GIMG	Rock	1651	MB2_Brit Pop						

Arpeggio Type List

Main Category	Sub Category	ARP No.	ARP Name	Time Signature	Length	Original Tempo	Accent	Random SFX	Voice Type
GIMG	Rock	1655	FC2_Brit Pop	4/4	1	86		○	"Mega 1coil SlapClean"
GIMG	Rock	1656	BA2_Brit Pop	4/4	1	86		○	:
GIMG	Rock	1657	MA_BritPopSwing_XS	4/4	2	110		○	"Mega Steel"
GIMG	Rock	1658	MB_BritPopSwing_XS	4/4	2	110		○	:
GIMG	Rock	1659	MC_BritPopSwing_XS	4/4	2	110		○	:
GIMG	Rock	1660	FA_BritPopSwing_XS	4/4	1	110		○	:
GIMG	Rock	1661	FB_BritPopSwing_XS	4/4	1	110		○	:
GIMG	Rock	1662	FC_BritPopSwing_XS	4/4	1	110		○	:
GIMG	Rock	1663	BA_BritPopSwing_XS	4/4	1	110		○	:
GIMG	Rock	1664	MA_BritPopSwing	4/4	2	110		○	:
GIMG	Rock	1665	MB_BritPopSwing	4/4	2	110		○	:
GIMG	Rock	1666	MC_BritPopSwing	4/4	2	110		○	:
GIMG	Rock	1667	FA_BritPopSwing	4/4	1	110		○	:
GIMG	Rock	1668	FB_BritPopSwing	4/4	1	110		○	:
GIMG	Rock	1669	FC_BritPopSwing	4/4	1	110		○	:
GIMG	Rock	1670	BA_BritPopSwing	4/4	1	110		○	:
GIMG	Rock	1671	MA_EP Ballad_XS	4/4	2	60		○	"Mega 1coil SlapClean"
GIMG	Rock	1672	MB_EP Ballad_XS	4/4	2	60		○	:
GIMG	Rock	1673	MC_EP Ballad_XS	4/4	2	60		○	:
GIMG	Rock	1674	FA_EP Ballad_XS	4/4	1	60		○	:
GIMG	Rock	1675	FB_EP Ballad_XS	4/4	1	60		○	:
GIMG	Rock	1676	FC_EP Ballad_XS	4/4	1	60		○	:
GIMG	Rock	1677	BA_EP Ballad_XS	4/4	1	60		○	:
GIMG	Rock	1678	MA_Cool 8Beat_XS	4/4	2	100		○	"Mega 60s ChorusCombo"
GIMG	Rock	1679	MB_Cool 8Beat_XS	4/4	2	100		○	:
GIMG	Rock	1680	MC_Cool 8Beat_XS	4/4	2	100		○	:
GIMG	Rock	1681	FA_Cool 8Beat_XS	4/4	1	100		○	:
GIMG	Rock	1682	FB_Cool 8Beat_XS	4/4	1	100		○	:
GIMG	Rock	1683	FC_Cool 8Beat_XS	4/4	1	100		○	:
GIMG	Rock	1684	BA_Cool 8Beat_XS	4/4	1	100		○	:
GIMG	R&B	1685	MA_Funk 1_XS	4/4	8	104		○	"Mega 1coil SlapClean"
GIMG	R&B	1686	MB_Funk 1_XS	4/4	8	104		○	:
GIMG	R&B	1687	MC_Funk 1_XS	4/4	8	104		○	:
GIMG	R&B	1688	FA_Funk 1_XS	4/4	1	104		○	:
GIMG	R&B	1689	FB_Funk 1_XS	4/4	1	104		○	:
GIMG	R&B	1690	FC_Funk 1_XS	4/4	1	104		○	:
GIMG	R&B	1691	BA_Funk 1_XS	4/4	1	104		○	:
GIMG	R&B	1692	MA1_Funk PopRock_XS	4/4	4	95		○	"Mega 60s Clean"
GIMG	R&B	1693	MB1_Funk PopRock_XS	4/4	4	95		○	:
GIMG	R&B	1694	MC1_Funk PopRock_XS	4/4	4	95		○	:
GIMG	R&B	1695	FA1_Funk PopRock_XS	4/4	1	95		○	:
GIMG	R&B	1696	FB1_Funk PopRock_XS	4/4	1	95		○	:
GIMG	R&B	1697	FC1_Funk PopRock_XS	4/4	1	95		○	:
GIMG	R&B	1698	BA1_Funk PopRock_XS	4/4	1	95		○	:
GIMG	R&B	1699	MA1_Funk PopRock	4/4	4	94		○	:
GIMG	R&B	1700	MB1_Funk PopRock	4/4	4	94		○	:
GIMG	R&B	1701	MC1_Funk PopRock	4/4	4	94		○	:
GIMG	R&B	1702	FA1_Funk PopRock	4/4	1	94		○	:
GIMG	R&B	1703	FB1_Funk PopRock	4/4	1	94		○	:
GIMG	R&B	1704	FC1_Funk PopRock	4/4	1	94		○	:
GIMG	R&B	1705	BA1_Funk PopRock	4/4	1	94		○	:
GIMG	R&B	1706	MA2_Funk PopRock_XS	4/4	4	95		○	"Mega 1coil Slap Dist"
GIMG	R&B	1707	MB2_Funk PopRock_XS	4/4	4	95		○	:
GIMG	R&B	1708	MC2_Funk PopRock_XS	4/4	4	95		○	:
GIMG	R&B	1709	FA2_Funk PopRock_XS	4/4	1	95		○	:
GIMG	R&B	1710	FB2_Funk PopRock_XS	4/4	1	95		○	:
GIMG	R&B	1711	FC2_Funk PopRock_XS	4/4	1	95		○	:
GIMG	R&B	1712	BA2_Funk PopRock_XS	4/4	1	95		○	:
GIMG	R&B	1713	MA2_Funk PopRock	4/4	4	94		○	:
GIMG	R&B	1714	MB2_Funk PopRock	4/4	4	94		○	:
GIMG	R&B	1715	MC2_Funk PopRock	4/4	4	94		○	:
GIMG	R&B	1716	FA2_Funk PopRock	4/4	1	94		○	:
GIMG	R&B	1717	FB2_Funk PopRock	4/4	1	94		○	:
GIMG	R&B	1718	FC2_Funk PopRock	4/4	1	94		○	:
GIMG	R&B	1719	BA2_Funk PopRock	4/4	1	94		○	:
GIMG	R&B	1720	MA_Jazz Funk 1_XS	4/4	4	120		○	"Mega 60s Clean"
GIMG	R&B	1721	MB_Jazz Funk 1_XS	4/4	4	120		○	:
GIMG	R&B	1722	MC_Jazz Funk 1_XS	4/4	4	120		○	:
GIMG	R&B	1723	FA_Jazz Funk 1_XS	4/4	1	120		○	:
GIMG	R&B	1724	FB_Jazz Funk 1_XS	4/4	1	120		○	:
GIMG	R&B	1725	FC_Jazz Funk 1_XS	4/4	1	120		○	:
GIMG	R&B	1726	BA_Jazz Funk 1_XS	4/4	1	120		○	:
GIMG	R&B	1727	MA_Jazz Funk 1	4/4	4	120		○	:
GIMG	R&B	1728	MB_Jazz Funk 1	4/4	4	120		○	:
GIMG	R&B	1729	MC_Jazz Funk 1	4/4	4	120		○	:
GIMG	R&B	1730	FA_Jazz Funk 1	4/4	1	120		○	:
GIMG	R&B	1731	FB_Jazz Funk 1	4/4	1	120		○	:
GIMG	R&B	1732	FC_Jazz Funk 1	4/4	1	120		○	:
GIMG	R&B	1733	BA_Jazz Funk 1	4/4	1	120		○	:
GIMG	R&B	1734	MA_Jazz Pop_XS	4/4	2	102		○	"Mega 60s ChorusCombo"
GIMG	R&B	1735	MB_Jazz Pop_XS	4/4	2	102		○	:
GIMG	R&B	1736	MC_Jazz Pop_XS	4/4	2	102		○	:
GIMG	R&B	1737	FA_Jazz Pop_XS	4/4	1	102		○	:

Main Category	Sub Category	ARP No.	ARP Name	Time Signature	Length	Original Tempo	Accent	Random SFX	Voice Type
GIMG	R&B	1738	FB_Jazz Pop_XS	4/4	1	102		○	"Mega 60s ChorusCombo"
GIMG	R&B	1739	FC_Jazz Pop_XS	4/4	1	102		○	:
GIMG	R&B	1740	BA_Jazz Pop_XS	4/4	1	102		○	:
GIMG	R&B	1741	MA_Jazz Pop	4/4	2	102		○	:
GIMG	R&B	1742	MB_Jazz Pop	4/4	2	102		○	:
GIMG	R&B	1743	MC_Jazz Pop	4/4	2	102		○	:
GIMG	R&B	1744	FA_Jazz Pop	4/4	1	102		○	:
GIMG	R&B	1745	FB_Jazz Pop	4/4	1	102		○	:
GIMG	R&B	1746	FC_Jazz Pop	4/4	1	102		○	:
GIMG	R&B	1747	BA_Jazz Pop	4/4	1	102		○	:
GIMG	R&B	1748	MA_Slow & Easy_XS	4/4	4	72		○	"Mega 60s Clean"
GIMG	R&B	1749	MB_Slow & Easy_XS	4/4	4	72		○	:
GIMG	R&B	1750	MC_Slow & Easy_XS	4/4	4	72		○	:
GIMG	R&B	1751	FA_Slow & Easy_XS	4/4	1	72		○	:
GIMG	R&B	1752	FB_Slow & Easy_XS	4/4	1	72		○	:
GIMG	R&B	1753	FC_Slow & Easy_XS	4/4	1	72		○	:
GIMG	R&B	1754	BA_Slow & Easy_XS	4/4	1	72		○	:
GIMG	R&B	1755	MA_Gospel Funk_XS	4/4	4	106		○	:
GIMG	R&B	1756	MB_Gospel Funk_XS	4/4	4	106		○	:
GIMG	R&B	1757	MC_Gospel Funk_XS	4/4	4	106		○	:
GIMG	R&B	1758	FA_Gospel Funk_XS	4/4	1	106		○	:
GIMG	R&B	1759	FB_Gospel Funk_XS	4/4	1	106		○	:
GIMG	R&B	1760	FC_Gospel Funk_XS	4/4	1	106		○	:
GIMG	R&B	1761	BA_Gospel Funk_XS	4/4	1	106		○	:
GIMG	R&B	1762	MA_Funk Disco_XS	4/4	2	126		○	"Mega 60s Small Blues"
GIMG	R&B	1763	MB_Funk Disco_XS	4/4	2	126		○	:
GIMG	R&B	1764	MC_Funk Disco_XS	4/4	2	126		○	:
GIMG	R&B	1765	FA_Funk Disco_XS	4/4	1	126		○	:
GIMG	R&B	1766	FB_Funk Disco_XS	4/4	1	126		○	:
GIMG	R&B	1767	FC_Funk Disco_XS	4/4	1	126		○	:
GIMG	R&B	1768	BA_Funk Disco_XS	4/4	1	126		○	:
GIMG	R&B	1769	MA_StandrdDisco_XS	4/4	4	120		○	"Mega 60s Clean"
GIMG	R&B	1770	MB_StandrdDisco_XS	4/4	4	120		○	:
GIMG	R&B	1771	MC_StandrdDisco_XS	4/4	4	120		○	:
GIMG	R&B	1772	FA_StandrdDisco_XS	4/4	1	120		○	:
GIMG	R&B	1773	FB_StandrdDisco_XS	4/4	1	120		○	:
GIMG	R&B	1774	FC_StandrdDisco_XS	4/4	1	120		○	:
GIMG	R&B	1775	BA_StandrdDisco_XS	4/4	1	120		○	:
GIMG	R&B	1776	MA_Retro Disco_XS	4/4	4	108		○	"Mega1coilSlpPedalWah"
GIMG	R&B	1777	MB_Retro Disco_XS	4/4	4	108		○	:
GIMG	R&B	1778	MC_Retro Disco_XS	4/4	4	108		○	:
GIMG	R&B	1779	FA_Retro Disco_XS	4/4	1	108		○	:
GIMG	R&B	1780	FB_Retro Disco_XS	4/4	1	108		○	:
GIMG	R&B	1781	FC_Retro Disco_XS	4/4	1	108		○	:
GIMG	R&B	1782	BA_Retro Disco_XS	4/4	1	108		○	:
GIMG	R&B	1783	MA_70sCoolDisco_XS	4/4	4	114		○	"Mega 60s ChorusCombo"
GIMG	R&B	1784	MB_70sCoolDisco_XS	4/4	4	114		○	:
GIMG	R&B	1785	MC_70sCoolDisco_XS	4/4	4	114		○	:
GIMG	R&B	1786	FA_70sCoolDisco_XS	4/4	1	114		○	:
GIMG	R&B	1787	FB_70sCoolDisco_XS	4/4	1	114		○	:
GIMG	R&B	1788	FC_70sCoolDisco_XS	4/4	1	114		○	:
GIMG	R&B	1789	BA_70sCoolDisco_XS	4/4	1	114		○	:
GIMG	R&B	1790	MA_70sDiscoFunk_XS	4/4	4	112		○	"Mega 1coil Slap Dist"
GIMG	R&B	1791	MB_70sDiscoFunk_XS	4/4	4	112		○	:
GIMG	R&B	1792	MC_70sDiscoFunk_XS	4/4	4	112		○	:
GIMG	R&B	1793	FA_70sDiscoFunk_XS	4/4	1	112		○	:
GIMG	R&B	1794	FB_70sDiscoFunk_XS	4/4	1	112		○	:
GIMG	R&B	1795	FC_70sDiscoFunk_XS	4/4	1	112		○	:
GIMG	R&B	1796	BA_70sDiscoFunk_XS	4/4	1	112		○	:
GIMG	R&B	1797	MA_Philadelphia_XS	4/4	2	100		○	"Mega 60s Pedal Wah"
GIMG	R&B	1798	MB_Philadelphia_XS	4/4	2	100		○	:
GIMG	R&B	1799	MC_Philadelphia_XS	4/4	2	100		○	:
GIMG	R&B	1800	FA_Philadelphia_XS	4/4	1	100		○	:
GIMG	R&B	1801	FB_Philadelphia_XS	4/4	1	100		○	:
GIMG	R&B	1802	FC_Philadelphia_XS	4/4	1	100		○	:
GIMG	R&B	1803	BA_Philadelphia_XS	4/4	1	100		○	:
GIMG	R&B	1804	MA_Philadelphia	4/4	2	100		○	:
GIMG	R&B	1805	MB_Philadelphia	4/4	2	100		○	:
GIMG	R&B	1806	MC_Philadelphia	4/4	2	100		○	:
GIMG	R&B	1807	FA_Philadelphia	4/4	1	100		○	:
GIMG	R&B	1808	FB_Philadelphia	4/4	1	100		○	:
GIMG	R&B	1809	FC_Philadelphia	4/4	1	100		○	:
GIMG	R&B	1810	BA_Philadelphia	4/4	1	100		○	:
GIMG	R&B	1811	MA_R&B_XS	4/4	2	83		○	"Mega 60s Tube Tone"
GIMG	R&B	1812	MB_R&B_XS	4/4	2	83		○	:
GIMG	R&B	1813	MC_R						

Arpeggio Type List

Main Category	Sub Category	ARP No.	ARP Name	Time Signature	Length	Original Tempo	Accent	Random SFX	Voice Type
GIMG	R&B	1821	FA_New R&B 1_XS	4/4	1	98		○	"Mega Steel"
GIMG	R&B	1822	FB_New R&B 1_XS	4/4	1	98		○	:
GIMG	R&B	1823	FC_New R&B 1_XS	4/4	1	98		○	:
GIMG	R&B	1824	BA_New R&B 1_XS	4/4	1	98		○	:
GIMG	R&B	1825	MA_R&B Ballad 1_XS	4/4	4	70		○	"Mega 60s Slap Clean"
GIMG	R&B	1826	MB_R&B Ballad 1_XS	4/4	4	70		○	:
GIMG	R&B	1827	MC_R&B Ballad 1_XS	4/4	4	70		○	:
GIMG	R&B	1828	FA_R&B Ballad 1_XS	4/4	1	70		○	:
GIMG	R&B	1829	FB_R&B Ballad 1_XS	4/4	1	70		○	:
GIMG	R&B	1830	FC_R&B Ballad 1_XS	4/4	1	70		○	:
GIMG	R&B	1831	BA_R&B Ballad 1_XS	4/4	1	70		○	:
GIMG	R&B	1832	MA_Soul 1_XS	4/4	2	116		○	"Mega 1coil Slap Dist"
GIMG	R&B	1833	MB_Soul 1_XS	4/4	2	116		○	:
GIMG	R&B	1834	MC_Soul 1_XS	4/4	2	116		○	:
GIMG	R&B	1835	FA_Soul 1_XS	4/4	1	116		○	:
GIMG	R&B	1836	FB_Soul 1_XS	4/4	1	116		○	:
GIMG	R&B	1837	FC_Soul 1_XS	4/4	1	116		○	:
GIMG	R&B	1838	BA_Soul 1_XS	4/4	1	116		○	:
GIMG	R&B	1839	MA_70sChartSoul_XS	4/4	2	108		○	"Mega 60s ChorusCombo"
GIMG	R&B	1840	MB_70sChartSoul_XS	4/4	2	108		○	:
GIMG	R&B	1841	MC_70sChartSoul_XS	4/4	2	108		○	:
GIMG	R&B	1842	FA_70sChartSoul_XS	4/4	1	108		○	:
GIMG	R&B	1843	FB_70sChartSoul_XS	4/4	1	108		○	:
GIMG	R&B	1844	FC_70sChartSoul_XS	4/4	1	108		○	:
GIMG	R&B	1845	BA_70sChartSoul_XS	4/4	1	108		○	:
GIMG	R&B	1846	MA_Frankly Soul_XS	4/4	4	120		○	"Mega 60s Clean"
GIMG	R&B	1847	MB_Frankly Soul_XS	4/4	4	120		○	:
GIMG	R&B	1848	MC_Frankly Soul_XS	4/4	4	120		○	:
GIMG	R&B	1849	FA_Frankly Soul_XS	4/4	1	120		○	:
GIMG	R&B	1850	FB_Frankly Soul_XS	4/4	1	120		○	:
GIMG	R&B	1851	FC_Frankly Soul_XS	4/4	1	120		○	:
GIMG	R&B	1852	BA_Frankly Soul_XS	4/4	1	120		○	:
GIMG	R&B	1853	MA_Frankly Soul	4/4	4	120		○	:
GIMG	R&B	1854	MB_Frankly Soul	4/4	4	120		○	:
GIMG	R&B	1855	MC_Frankly Soul	4/4	4	120		○	:
GIMG	R&B	1856	FA_Frankly Soul	4/4	1	120		○	:
GIMG	R&B	1857	FB_Frankly Soul	4/4	1	120		○	:
GIMG	R&B	1858	FC_Frankly Soul	4/4	1	120		○	:
GIMG	R&B	1859	BA_Frankly Soul	4/4	1	120		○	:
GIMG	R&B	1860	MA_Soul Beat_XS	4/4	4	124		○	:
GIMG	R&B	1861	MB_Soul Beat_XS	4/4	4	124		○	:
GIMG	R&B	1862	MC_Soul Beat_XS	4/4	4	124		○	:
GIMG	R&B	1863	FA_Soul Beat_XS	4/4	1	124		○	:
GIMG	R&B	1864	FB_Soul Beat_XS	4/4	1	124		○	:
GIMG	R&B	1865	FC_Soul Beat_XS	4/4	1	124		○	:
GIMG	R&B	1866	BA_Soul Beat_XS	4/4	1	124		○	:
GIMG	R&B	1867	MA1_Soul Band_XS	4/4	4	129		○	"Mega Steel"
GIMG	R&B	1868	MB1_Soul Band_XS	4/4	4	129		○	:
GIMG	R&B	1869	MC1_Soul Band_XS	4/4	4	129		○	:
GIMG	R&B	1870	FA1_Soul Band_XS	4/4	1	129		○	:
GIMG	R&B	1871	FB1_Soul Band_XS	4/4	1	129		○	:
GIMG	R&B	1872	FC1_Soul Band_XS	4/4	1	129		○	:
GIMG	R&B	1873	BA1_Soul Band_XS	4/4	1	129		○	:
GIMG	R&B	1874	MA2_Soul Band_XS	4/4	4	129		○	"Mega 60s Tube Tone"
GIMG	R&B	1875	MB2_Soul Band_XS	4/4	4	129		○	:
GIMG	R&B	1876	MC2_Soul Band_XS	4/4	4	129		○	:
GIMG	R&B	1877	FA2_Soul Band_XS	4/4	1	129		○	:
GIMG	R&B	1878	FB2_Soul Band_XS	4/4	1	129		○	:
GIMG	R&B	1879	FC2_Soul Band_XS	4/4	1	129		○	:
GIMG	R&B	1880	BA2_Soul Band_XS	4/4	1	129		○	:
GIMG	R&B	1881	MA_Soul Shuffle_XS	4/4	4	98		○	"Mega 60s Clean"
GIMG	R&B	1882	MB_Soul Shuffle_XS	4/4	4	98		○	:
GIMG	R&B	1883	MC_Soul Shuffle_XS	4/4	4	98		○	:
GIMG	R&B	1884	FA_Soul Shuffle_XS	4/4	1	98		○	:
GIMG	R&B	1885	FB_Soul Shuffle_XS	4/4	1	98		○	:
GIMG	R&B	1886	FC_Soul Shuffle_XS	4/4	1	98		○	:
GIMG	R&B	1887	BA_Soul Shuffle_XS	4/4	1	98		○	:
GIMG	R&B	1888	MA_Soul Swing_XS	4/4	4	124		○	:
GIMG	R&B	1889	MB_Soul Swing_XS	4/4	4	124		○	:
GIMG	R&B	1890	MC_Soul Swing_XS	4/4	4	124		○	:
GIMG	R&B	1891	FA_Soul Swing_XS	4/4	1	124		○	:
GIMG	R&B	1892	FB_Soul Swing_XS	4/4	1	124		○	:
GIMG	R&B	1893	FC_Soul Swing_XS	4/4	1	124		○	:
GIMG	R&B	1894	BA_Soul Swing_XS	4/4	1	124		○	:
GIMG	R&B	1895	MA_GospelBrothr_XS	4/4	4	108		○	"Mega 60s ChorusCombo"
GIMG	R&B	1896	MB_GospelBrothr_XS	4/4	4	108		○	:
GIMG	R&B	1897	MC_GospelBrothr_XS	4/4	4	108		○	:
GIMG	R&B	1898	FA_GospelBrothr_XS	4/4	1	108		○	:
GIMG	R&B	1899	FB_GospelBrothr_XS	4/4	1	108		○	:
GIMG	R&B	1900	FC_GospelBrothr_XS	4/4	1	108		○	:
GIMG	R&B	1901	BA_GospelBrothr_XS	4/4	1	108		○	:
GIMG	Elect	1902	MA_Disco House_XS	4/4	4	126		○	:
GIMG	Elect	1903	MB_Disco House_XS	4/4	4	126		○	:

Main Category	Sub Category	ARP No.	ARP Name	Time Signature	Length	Original Tempo	Accent	Random SFX	Voice Type
GIMG	Elect	1904	MC_Disco House_XS	4/4	4	126		○	"Mega 60s ChorusCombo"
GIMG	Elect	1905	FA_Disco House_XS	4/4	1	126		○	:
GIMG	Elect	1906	FB_Disco House_XS	4/4	1	126		○	:
GIMG	Elect	1907	FC_Disco House_XS	4/4	1	126		○	:
GIMG	Elect	1908	BA_Disco House_XS	4/4	1	126		○	:
GIMG	Jazz	1909	MA_ShuffleBlues_XS	4/4	4	115		○	"Mega 60s Tube Tone"
GIMG	Jazz	1910	MB_ShuffleBlues_XS	4/4	4	115		○	:
GIMG	Jazz	1911	MC_ShuffleBlues_XS	4/4	4	115		○	:
GIMG	Jazz	1912	FA_ShuffleBlues_XS	4/4	1	115		○	:
GIMG	Jazz	1913	FB_ShuffleBlues_XS	4/4	1	115		○	:
GIMG	Jazz	1914	FC_ShuffleBlues_XS	4/4	1	115		○	:
GIMG	Jazz	1915	BA_ShuffleBlues_XS	4/4	1	115		○	:
GIMG	Jazz	1916	MA_Slow Blues 1_XS	4/4	2	49		○	:
GIMG	Jazz	1917	MB_Slow Blues 1_XS	4/4	2	49		○	:
GIMG	Jazz	1918	MC_Slow Blues 1_XS	4/4	2	49		○	:
GIMG	Jazz	1919	FA_Slow Blues 1_XS	4/4	1	49		○	:
GIMG	Jazz	1920	FB_Slow Blues 1_XS	4/4	1	49		○	:
GIMG	Jazz	1921	FC_Slow Blues 1_XS	4/4	1	49		○	:
GIMG	Jazz	1922	BA_Slow Blues 1_XS	4/4	1	49		○	:
GIMG	Jazz	1923	MA_Piano Boogie_XS	4/4	8	160		○	"Mega 60s ChorusCombo"
GIMG	Jazz	1924	MB_Piano Boogie_XS	4/4	4	160		○	:
GIMG	Jazz	1925	MC_Piano Boogie_XS	4/4	4	160		○	:
GIMG	Jazz	1926	FA_Piano Boogie_XS	4/4	1	160		○	:
GIMG	Jazz	1927	FB_Piano Boogie_XS	4/4	1	160		○	:
GIMG	Jazz	1928	FC_Piano Boogie_XS	4/4	1	160		○	:
GIMG	Jazz	1929	BA_Piano Boogie_XS	4/4	1	160		○	:
GIMG	World	1930	MA1_ReggaeShuffle_XS	4/4	4	90		○	"Mega 60s Clean"
GIMG	World	1931	MB1_ReggaeShuffle_XS	4/4	4	90		○	:
GIMG	World	1932	MC1_ReggaeShuffle_XS	4/4	4	90		○	:
GIMG	World	1933	FA1_ReggaeShuffle_XS	4/4	1	90		○	:
GIMG	World	1934	FB1_ReggaeShuffle_XS	4/4	1	90		○	:
GIMG	World	1935	FC1_ReggaeShuffle_XS	4/4	1	90		○	:
GIMG	World	1936	BA1_ReggaeShuffle_XS	4/4	1	90		○	:
GIMG	World	1937	MA2_ReggaeShuffle_XS	4/4	4	90		○	"Mega 1coil SlapClean"
GIMG	World	1938	MB2_ReggaeShuffle_XS	4/4	4	90		○	:
GIMG	World	1939	MC2_ReggaeShuffle_XS	4/4	4	90		○	:
GIMG	World	1940	FA2_ReggaeShuffle_XS	4/4	1	90		○	:
GIMG	World	1941	FB2_ReggaeShuffle_XS	4/4	1	90		○	:
GIMG	World	1942	FC2_ReggaeShuffle_XS	4/4	1	90		○	:
GIMG	World	1943	BA2_ReggaeShuffle_XS	4/4	1	90		○	:
GIMG	World	1944	MA_Jumbo Reggae_XS	4/4	4	100		○	"Mega 60s Clean"
GIMG	World	1945	MB_Jumbo Reggae_XS	4/4	4	100		○	:
GIMG	World	1946	MC_Jumbo Reggae_XS	4/4	4	100		○	:
GIMG	World	1947	FA_Jumbo Reggae_XS	4/4	1	100		○	:
GIMG	World	1948	FB_Jumbo Reggae_XS	4/4	1	100		○	:
GIMG	World	1949	FC_Jumbo Reggae_XS	4/4	1	100		○	:
GIMG	World	1950	BA_Jumbo Reggae_XS	4/4	1	100		○	:
GIMG	World	1951	MA_Brazil Samba_XS	4/4	4	96		○	"Mega Nylon"
GIMG	World	1952	MB_Brazil Samba_XS	4/4	4	96		○	:
GIMG	World	1953	MC_Brazil Samba_XS	4/4	4	96		○	:
GIMG	World	1954	FA_Brazil Samba_XS	4/4	1	96		○	:
GIMG	World	1955	FB_Brazil Samba_XS	4/4	1	96		○	:
GIMG	World	1956	FC_Brazil Samba_XS	4/4	1	96		○	:
GIMG	World	1957	BA_Brazil Samba_XS	4/4	1	96		○	:
GIMG	World	1958	MA_Bossa_XS	4/4	4	124		○	:
GIMG	World	1959	MB_Bossa_XS	4/4	4	124		○	:
GIMG	World	1960	MC_Bossa_XS	4/4	4	124		○	:
GIMG	World	1961	FA_Bossa_XS	4/4	1	124		○	:
GIMG	World	1962	FB_Bossa_XS	4/4	1	124		○	:
GIMG	World	1963	FC_Bossa_XS	4/4	1	124		○	:
GIMG	World	1964	BA_Bossa_XS	4/4	1	124		○	:
GIMG	World	1965	MA_Bossa	4/4	4	123		○	:
GIMG	World	1966	MB_Bossa	4/4	4	123		○	:
GIMG	World	1967	MC_Bossa	4/4	4	123		○	:
GIMG	World	1968	FA_Bossa	4/4	1	123		○	:
GIMG	World	1969	FB_Bossa	4/4	1	123		○	:
GIMG	World	1970	FC_Bossa	4/4	1	123		○	:
GIMG	World	1971	BA_Bossa	4/4	1	123		○	:
GIMG	World	1972	MA_Merengue_XS	4/4	4	130		○	"Mega Steel"
GIMG	World	1973	MB_Merengue_XS	4/4	4	130		○	:
GIMG	World	1974	MC_Merengue_XS	4/4	4	130		○	:
GIMG	World	1975	FA_Merengue_XS	4/4	1	130		○	:
GIMG	World	1976	FB_Merengue_XS	4/4	1	130		○	:
GIMG	World	1977	FC_Merengue_XS	4/4	1	130		○	:
GIMG	World	1978	BA_Merengue_XS	4/4	1	130		○	:
GIMG	World	1979	MA_Merengue	4/4	4	130		○	:
GIMG	World	1980	MB_Merengue	4/4	4	130			

Main Category	Sub Category	ARP No.	ARP Name	Time Signature	Length	Original Tempo	Accent	Random SFX	Voice Type
GIMG	World	1987	MB_RumbaFlamenc_XS	4/4	4	106		○	"Mega Nylon"
GIMG	World	1988	MC_RumbaFlamenc_XS	4/4	4	106		○	:
GIMG	World	1989	FA_RumbaFlamenc_XS	4/4	1	106		○	:
GIMG	World	1990	FB_RumbaFlamenc_XS	4/4	1	106		○	:
GIMG	World	1991	FC_RumbaFlamenc_XS	4/4	1	106		○	:
GIMG	World	1992	BA_RumbaFlamenc_XS	4/4	1	106		○	:
GIMG	World	1993	MA_Irish Hymn_XS	3/4	4	70		○	"Mega Steel"
GIMG	World	1994	MB_Irish Hymn_XS	3/4	4	70		○	:
GIMG	World	1995	MC_Irish Hymn_XS	3/4	4	70		○	:
GIMG	World	1996	FA_Irish Hymn_XS	3/4	1	70		○	:
GIMG	World	1997	FB_Irish Hymn_XS	3/4	1	70		○	:
GIMG	World	1998	FC_Irish Hymn_XS	3/4	1	70		○	:
GIMG	World	1999	BA_Irish Hymn_XS	3/4	1	70		○	:
Bass	Rock	2000	MA_AlternaRock1_ES	4/4	4	97			Finger Bass
Bass	Rock	2001	MB_AlternaRock1_ES	4/4	4	97			:
Bass	Rock	2002	MC_AlternaRock1_ES	4/4	4	97			:
Bass	Rock	2003	FA_AlternaRock1_ES	4/4	1	97			:
Bass	Rock	2004	FB_AlternaRock1_ES	4/4	1	97			:
Bass	Rock	2005	FC_AlternaRock1_ES	4/4	1	97			:
Bass	Rock	2006	BA_AlternaRock1_ES	4/4	1	97			:
Bass	Rock	2007	MA_AlternaRock2_ES	4/4	4	100			:
Bass	Rock	2008	MB_AlternaRock2_ES	4/4	4	100			:
Bass	Rock	2009	MC_AlternaRock2_ES	4/4	4	100			:
Bass	Rock	2010	FA_AlternaRock2_ES	4/4	1	100			:
Bass	Rock	2011	FB_AlternaRock2_ES	4/4	1	100			:
Bass	Rock	2012	FC_AlternaRock2_ES	4/4	1	100			:
Bass	Rock	2013	BA_AlternaRock2_ES	4/4	1	100			:
Bass	Rock	2014	MA_Xover Rock_ES	4/4	1	100			:
Bass	Rock	2015	MB_Xover Rock_ES	4/4	1	100			:
Bass	Rock	2016	MC_Xover Rock_ES	4/4	2	100			:
Bass	Rock	2017	MD_Xover Rock_ES	4/4	2	100			:
Bass	Rock	2018	IA_Xover Rock_ES	4/4	2	100			:
Bass	Rock	2019	FB_Xover Rock_ES	4/4	1	100			:
Bass	Rock	2020	FC_Xover Rock_ES	4/4	2	100			:
Bass	Rock	2021	MA_Guitar Pop 2_ES	4/4	2	90			:
Bass	Rock	2022	MB_Guitar Pop 2_ES	4/4	1	90			:
Bass	Rock	2023	MC_Guitar Pop 2_ES	4/4	2	90			:
Bass	Rock	2024	MD_Guitar Pop 2_ES	4/4	2	90			:
Bass	Rock	2025	FB_Guitar Pop 2_ES	4/4	1	90			:
Bass	Rock	2026	FC_Guitar Pop 2_ES	4/4	2	90			:
Bass	Rock	2027	MA_Unplugged 3_XS	4/4	4	113			Acoustic Bass
Bass	Rock	2028	MB_Unplugged 3_XS	4/4	4	113			:
Bass	Rock	2029	MC_Unplugged 3_XS	4/4	4	113			:
Bass	Rock	2030	FA_Unplugged 3_XS	4/4	1	113			:
Bass	Rock	2031	FB_Unplugged 3_XS	4/4	1	113			:
Bass	Rock	2032	FC_Unplugged 3_XS	4/4	1	113			:
Bass	Rock	2033	BA_Unplugged 3_XS	4/4	1	113			:
Bass	Rock	2034	MA_Unplugged 3_ES	4/4	4	113			:
Bass	Rock	2035	MB_Unplugged 3_ES	4/4	4	113			:
Bass	Rock	2036	MC_Unplugged 3_ES	4/4	4	113			:
Bass	Rock	2037	FA_Unplugged 3_ES	4/4	1	113			:
Bass	Rock	2038	FB_Unplugged 3_ES	4/4	1	113			:
Bass	Rock	2039	FC_Unplugged 3_ES	4/4	1	113			:
Bass	Rock	2040	BA_Unplugged 3_ES	4/4	1	113			:
Bass	Rock	2041	MA_FingerPickin_ES	4/4	1	94			Finger Bass
Bass	Rock	2042	MB_FingerPickin_ES	4/4	2	94			:
Bass	Rock	2043	MC_FingerPickin_ES	4/4	1	94			:
Bass	Rock	2044	MD_FingerPickin_ES	4/4	1	94			:
Bass	Rock	2045	FA_FingerPickin_ES	4/4	1	94			:
Bass	Rock	2046	FB_FingerPickin_ES	4/4	1	94			:
Bass	Rock	2047	FC_FingerPickin_ES	4/4	1	94			:
Bass	Rock	2048	MA_Folk Rock_ES	4/4	1	120			:
Bass	Rock	2049	MC_Folk Rock_ES	4/4	1	120			:
Bass	Rock	2050	MD_Folk Rock_ES	4/4	1	120			:
Bass	Rock	2051	FA_Folk Rock_ES	4/4	1	120			:
Bass	Rock	2052	FC_Folk Rock_ES	4/4	1	120			:
Bass	Rock	2053	MA_70s Rock_ES	4/4	4	130			:
Bass	Rock	2054	MC_70s Rock_ES	4/4	2	130			:
Bass	Rock	2055	MD_70s Rock_ES	4/4	4	130			:
Bass	Rock	2056	FA_70s Rock_ES	4/4	1	130			:
Bass	Rock	2057	MA_8Beat Basic_XS	4/4	4	120			:
Bass	Rock	2058	MB_8Beat Basic_XS	4/4	4	120			:
Bass	Rock	2059	MC_8Beat Basic_XS	4/4	4	120			:
Bass	Rock	2060	FA_8Beat Basic_XS	4/4	1	120			:
Bass	Rock	2061	FB_8Beat Basic_XS	4/4	1	120			:
Bass	Rock	2062	FC_8Beat Basic_XS	4/4	1	120			:
Bass	Rock	2063	BA_8Beat Basic_XS	4/4	1	120			:
Bass	Rock	2064	MA_8Beat Basic_ES	4/4	4	120			:
Bass	Rock	2065	MB_8Beat Basic_ES	4/4	4	120			:
Bass	Rock	2066	MC_8Beat Basic_ES	4/4	4	120			:
Bass	Rock	2067	FA_8Beat Basic_ES	4/4	1	120			:
Bass	Rock	2068	FB_8Beat Basic_ES	4/4	1	120			:
Bass	Rock	2069	FC_8Beat Basic_ES	4/4	1	120			:

Main Category	Sub Category	ARP No.	ARP Name	Time Signature	Length	Original Tempo	Accent	Random SFX	Voice Type
Bass	Rock	2070	BA_8Beat Basic_ES	4/4	1	120			Finger Bass
Bass	Rock	2071	MA_8Beat Rock_XS	4/4	4	75			:
Bass	Rock	2072	MB_8Beat Rock_XS	4/4	4	75			:
Bass	Rock	2073	MC_8Beat Rock_XS	4/4	4	75			:
Bass	Rock	2074	FA_8Beat Rock_XS	4/4	1	75			:
Bass	Rock	2075	FB_8Beat Rock_XS	4/4	1	75			:
Bass	Rock	2076	FC_8Beat Rock_XS	4/4	1	75			:
Bass	Rock	2077	BA_8Beat Rock_XS	4/4	1	75			:
Bass	Rock	2078	MA_8Beat Rock_ES	4/4	4	75			:
Bass	Rock	2079	MB_8Beat Rock_ES	4/4	4	75			:
Bass	Rock	2080	MC_8Beat Rock_ES	4/4	4	75			:
Bass	Rock	2081	FA_8Beat Rock_ES	4/4	1	75			:
Bass	Rock	2082	FB_8Beat Rock_ES	4/4	1	75			:
Bass	Rock	2083	FC_8Beat Rock_ES	4/4	1	75			:
Bass	Rock	2084	BA_8Beat Rock_ES	4/4	1	75			:
Bass	Rock	2085	MA_8Beat Slow_XS	4/4	4	78			:
Bass	Rock	2086	MB_8Beat Slow_XS	4/4	4	78			:
Bass	Rock	2087	MC_8Beat Slow_XS	4/4	4	78			:
Bass	Rock	2088	FA_8Beat Slow_XS	4/4	1	78			:
Bass	Rock	2089	FB_8Beat Slow_XS	4/4	1	78			:
Bass	Rock	2090	FC_8Beat Slow_XS	4/4	1	78			:
Bass	Rock	2091	BA_8Beat Slow_XS	4/4	1	78			:
Bass	Rock	2092	MA_8Beat Slow_ES	4/4	4	78			:
Bass	Rock	2093	MB_8Beat Slow_ES	4/4	4	78			:
Bass	Rock	2094	MC_8Beat Slow_ES	4/4	4	78			:
Bass	Rock	2095	FA_8Beat Slow_ES	4/4	1	78			:
Bass	Rock	2096	FB_8Beat Slow_ES	4/4	1	78			:
Bass	Rock	2097	FC_8Beat Slow_ES	4/4	1	78			:
Bass	Rock	2098	BA_8Beat Slow_ES	4/4	1	78			:
Bass	Rock	2099	MA_8Beat Soft_XS	4/4	4	100			:
Bass	Rock	2100	MB_8Beat Soft_XS	4/4	4	100			:
Bass	Rock	2101	MC_8Beat Soft_XS	4/4	4	100			:
Bass	Rock	2102	FA_8Beat Soft_XS	4/4	1	100			:
Bass	Rock	2103	FB_8Beat Soft_XS	4/4	1	100			:
Bass	Rock	2104	FC_8Beat Soft_XS	4/4	1	100			:
Bass	Rock	2105	BA_8Beat Soft_XS	4/4	1	100			:
Bass	Rock	2106	MA_8Beat Soft_ES	4/4	4	100			:
Bass	Rock	2107	MB_8Beat Soft_ES	4/4	4	100			:
Bass	Rock	2108	MC_8Beat Soft_ES	4/4	4	100			:
Bass	Rock	2109	FA_8Beat Soft_ES	4/4	1	100			:
Bass	Rock	2110	FB_8Beat Soft_ES	4/4	1	100			:
Bass	Rock	2111	FC_8Beat Soft_ES	4/4	1	100			:
Bass	Rock	2112	BA_8Beat Soft_ES	4/4	1	100			:
Bass	Rock	2113	MA_Soft Rock_ES	4/4	1	120			:
Bass	Rock	2114	MB_Soft Rock_ES	4/4	1	120			:
Bass	Rock	2115	MC_Soft Rock_ES	4/4	1	120			:
Bass	Rock	2116	MD_Soft Rock_ES	4/4	1	120			:
Bass	Rock	2117	IA_Soft Rock_ES	4/4	1	120			:
Bass	Rock	2118	FA_Soft Rock_ES	4/4	1	120			:
Bass	Rock	2119	FB_Soft Rock_ES	4/4	1	120			:
Bass	Rock	2120	MA_Slowfeel_ES	4/4	1	74			Fretless Bass
Bass	Rock	2121	MB_Slowfeel_ES	4/4	1	74			:
Bass	Rock	2122	MC_Slowfeel_ES	4/4	1	74			:
Bass	Rock	2123	MD_Slowfeel_ES	4/4	1	74			:
Bass	Rock	2124	IA_Slowfeel_ES	4/4	2	74			:
Bass	Rock	2125	FA_Slowfeel_ES	4/4	1	74			:
Bass	Rock	2126	FB_Slowfeel_ES	4/4	1	74			:
Bass	Rock	2127	FC_Slowfeel_ES	4/4	2	74			:
Bass	Rock	2128	MA_16Bt Ballad1_XS	4/4	4	75			Finger Bass
Bass	Rock	2129	MB_16Bt Ballad1_XS	4/4	4	75			:
Bass	Rock	2130	MC_16Bt Ballad1_XS	4/4	4	75			:
Bass	Rock	2131	FA_16Bt Ballad1_XS	4/4	1	75			:
Bass	Rock	2132	FB_16Bt Ballad1_XS	4/4	1	75			:
Bass	Rock	2133	FC_16Bt Ballad1_XS	4/4	1	75			:
Bass	Rock	2134	BA_16Bt Ballad1_XS	4/4	1	75			:
Bass	Rock	2135	MA_16Bt Ballad1_ES	4/4	4	75			:
Bass	Rock	2136	MB_16Bt Ballad1_ES	4/4	4	75			:
Bass	Rock	2137	MC_16Bt Ballad1_ES	4/4	4	75			:
Bass	Rock	2138	FA_16Bt Ballad1_ES	4/4	1	75			:
Bass	Rock	2139	FB_16Bt Ballad1_ES	4/4	1	75			:
Bass	Rock	2140	FC_16Bt Ballad1_ES	4/4	1	75			:
Bass	Rock	2141	BA_16Bt Ballad1_ES	4/4	1	75			:
Bass	Rock	2142	MA_16BeatBasic1_XS	4/4	4	90			Finger/Slap Bass
Bass	Rock	2143	MB_16BeatBasic1_XS	4/4	4	90			:
Bass	Rock	2144	MC_16BeatBasic1_XS	4/4	4	90			:
Bass	Rock	2145	FA_16BeatBasic1_XS	4/4	1	90			:
Bass	Rock	2146	FB_16BeatBasic1_XS	4/4	1	90			:
Bass	Rock	2147	FC_16BeatBasic1_XS	4/4	1	90			:
Bass	Rock	2148	MA_16BeatBasic1_XS	4/4	1	90			:
Bass	Rock	2149	MB_16BeatBasic1_ES	4/4	4	90			:
Bass	Rock	2150	MC_16BeatBasic1_ES	4/4	4	90			:
Bass	Rock	2151	MA_16BeatBasic1_ES	4/4	4	90			:
Bass	Rock	2152	FA_16BeatBasic1_ES	4/4	1	90			:

Arpeggio Type List

Main Category	Sub Category	ARP No.	ARP Name	Time Signature	Length	Original Tempo	Accent	Random SFX	Voice Type
Bass	Rock	2153	FB_16BeatBasic1_ES	4/4	1	90			Finger/Slap Bass
Bass	Rock	2154	FC_16BeatBasic1_ES	4/4	1	90			:
Bass	Rock	2155	BA_16BeatBasic1_ES	4/4	1	90			:
Bass	Rock	2156	MA_16BeatBasic2_XS	4/4	4	77			Synth Bass
Bass	Rock	2157	MB_16BeatBasic2_XS	4/4	4	77			:
Bass	Rock	2158	MC_16BeatBasic2_XS	4/4	4	77			:
Bass	Rock	2159	FA_16BeatBasic2_XS	4/4	1	77			:
Bass	Rock	2160	FB_16BeatBasic2_XS	4/4	1	77			:
Bass	Rock	2161	FC_16BeatBasic2_XS	4/4	1	77			:
Bass	Rock	2162	BA_16BeatBasic2_XS	4/4	1	77			:
Bass	Rock	2163	MA_16BeatBasic2_ES	4/4	3	77			:
Bass	Rock	2164	MB_16BeatBasic2_ES	4/4	4	77			:
Bass	Rock	2165	MC_16BeatBasic2_ES	4/4	4	77			:
Bass	Rock	2166	FA_16BeatBasic2_ES	4/4	1	77			:
Bass	Rock	2167	FB_16BeatBasic2_ES	4/4	1	77			:
Bass	Rock	2168	FC_16BeatBasic2_ES	4/4	1	77			:
Bass	Rock	2169	BA_16BeatBasic2_ES	4/4	1	77			:
Bass	Rock	2170	MA_16Beat Pop 2_XS	4/4	4	94			:
Bass	Rock	2171	MB_16Beat Pop 2_XS	4/4	4	94			:
Bass	Rock	2172	MC_16Beat Pop 2_XS	4/4	4	94			:
Bass	Rock	2173	FA_16Beat Pop 2_XS	4/4	1	94			:
Bass	Rock	2174	FB_16Beat Pop 2_XS	4/4	1	94			:
Bass	Rock	2175	FC_16Beat Pop 2_XS	4/4	1	94			:
Bass	Rock	2176	BA_16Beat Pop 2_XS	4/4	1	94			:
Bass	Rock	2177	MA_16Beat Pop 2_ES	4/4	4	94			:
Bass	Rock	2178	MB_16Beat Pop 2_ES	4/4	4	94			:
Bass	Rock	2179	MC_16Beat Pop 2_ES	4/4	4	94			:
Bass	Rock	2180	FA_16Beat Pop 2_ES	4/4	1	94			:
Bass	Rock	2181	FB_16Beat Pop 2_ES	4/4	1	94			:
Bass	Rock	2182	FC_16Beat Pop 2_ES	4/4	1	94			:
Bass	Rock	2183	BA_16Beat Pop 2_ES	4/4	1	94			:
Bass	Rock	2184	MA_16Beat Rock_XS	4/4	4	86			:
Bass	Rock	2185	MB_16Beat Rock_XS	4/4	4	86			:
Bass	Rock	2186	MC_16Beat Rock_XS	4/4	4	86			:
Bass	Rock	2187	FA_16Beat Rock_XS	4/4	1	86			:
Bass	Rock	2188	FB_16Beat Rock_XS	4/4	1	86			:
Bass	Rock	2189	FC_16Beat Rock_XS	4/4	1	86			:
Bass	Rock	2190	BA_16Beat Rock_XS	4/4	1	86			:
Bass	Rock	2191	MA_16Beat Rock_ES	4/4	4	86			:
Bass	Rock	2192	MB_16Beat Rock_ES	4/4	4	86			:
Bass	Rock	2193	MC_16Beat Rock_ES	4/4	4	86			:
Bass	Rock	2194	FA_16Beat Rock_ES	4/4	1	86			:
Bass	Rock	2195	FB_16Beat Rock_ES	4/4	1	86			:
Bass	Rock	2196	FC_16Beat Rock_ES	4/4	1	86			:
Bass	Rock	2197	BA_16Beat Rock_ES	4/4	1	86			:
Bass	Rock	2198	MA_Piano Club_ES	4/4	2	96			Finger Bass
Bass	Rock	2199	MB_Piano Club_ES	4/4	2	96			:
Bass	Rock	2200	MC_Piano Club_ES	4/4	2	96			:
Bass	Rock	2201	MD_Piano Club_ES	4/4	1	96			:
Bass	Rock	2202	IA_Piano Club_ES	4/4	2	96			:
Bass	Rock	2203	FA_Piano Club_ES	4/4	1	96			:
Bass	Rock	2204	FB_Piano Club_ES	4/4	1	96			:
Bass	Rock	2205	FC_Piano Club_ES	4/4	4	96			:
Bass	Rock	2206	MA_Analog Pop_ES	4/4	2	93			Pick Bass
Bass	Rock	2207	MB_Analog Pop_ES	4/4	2	93			:
Bass	Rock	2208	MC_Analog Pop_ES	4/4	2	93			:
Bass	Rock	2209	MD_Analog Pop_ES	4/4	4	93			:
Bass	Rock	2210	IA_Analog Pop_ES	4/4	2	93			:
Bass	Rock	2211	FA_Analog Pop_ES	4/4	1	93			:
Bass	Rock	2212	FB_Analog Pop_ES	4/4	1	93			:
Bass	Rock	2213	FC_Analog Pop_ES	4/4	2	93			:
Bass	Rock	2214	MA_6/8 Pop_XS	4/4	4	100			Finger/Slap Bass
Bass	Rock	2215	MB_6/8 Pop_XS	4/4	4	100			:
Bass	Rock	2216	MC_6/8 Pop_XS	4/4	4	100			:
Bass	Rock	2217	FA_6/8 Pop_XS	4/4	1	100			:
Bass	Rock	2218	FB_6/8 Pop_XS	4/4	1	100			:
Bass	Rock	2219	FC_6/8 Pop_XS	4/4	1	100			:
Bass	Rock	2220	BA_6/8 Pop_XS	4/4	1	100			:
Bass	Rock	2221	MA_6/8 Pop_ES	4/4	4	100			:
Bass	Rock	2222	MB_6/8 Pop_ES	4/4	4	100			:
Bass	Rock	2223	MC_6/8 Pop_ES	4/4	4	100			:
Bass	Rock	2224	FA_6/8 Pop_ES	4/4	1	100			:
Bass	Rock	2225	FB_6/8 Pop_ES	4/4	1	100			:
Bass	Rock	2226	FC_6/8 Pop_ES	4/4	1	100			:
Bass	Rock	2227	BA_6/8 Pop_ES	4/4	1	100			:
Bass	Rock	2228	MA_6/8 Ballad_XS	6/8	4	87			:
Bass	Rock	2229	MB_6/8 Ballad_XS	6/8	4	87			:
Bass	Rock	2230	MC_6/8 Ballad_XS	6/8	4	87			:
Bass	Rock	2231	FA_6/8 Ballad_XS	6/8	1	87			:
Bass	Rock	2232	FB_6/8 Ballad_XS	6/8	1	87			:
Bass	Rock	2233	FC_6/8 Ballad_XS	6/8	1	87			:
Bass	Rock	2234	BA_6/8 Ballad_XS	6/8	1	87			:
Bass	Rock	2235	MA_6/8 Ballad_ES	6/8	4	87			:

Main Category	Sub Category	ARP No.	ARP Name	Time Signature	Length	Original Tempo	Accent	Random SFX	Voice Type
Bass	Rock	2236	MB_6/8 Ballad_ES	6/8	4	87			Finger/Slap Bass
Bass	Rock	2237	MC_6/8 Ballad_ES	6/8	4	87			:
Bass	Rock	2238	FA_6/8 Ballad_ES	6/8	1	87			:
Bass	Rock	2239	FB_6/8 Ballad_ES	6/8	1	87			:
Bass	Rock	2240	FC_6/8 Ballad_ES	6/8	1	87			:
Bass	Rock	2241	BA_6/8 Ballad_ES	6/8	1	87			:
Bass	Rock	2242	MA_ProgresRock1_XS	4/4	4	110			Synth Bass
Bass	Rock	2243	MB_ProgresRock1_XS	4/4	3	110			:
Bass	Rock	2244	MC_ProgresRock1_XS	4/4	4	110			:
Bass	Rock	2245	FA_ProgresRock1_XS	4/4	1	110			:
Bass	Rock	2246	FB_ProgresRock1_XS	4/4	1	110			:
Bass	Rock	2247	FC_ProgresRock1_XS	4/4	1	110			:
Bass	Rock	2248	BA_ProgresRock1_XS	4/4	1	110			:
Bass	Rock	2249	MA_ProgresRock1_ES	4/4	4	110			:
Bass	Rock	2250	MB_ProgresRock1_ES	4/4	3	110			:
Bass	Rock	2251	MC_ProgresRock1_ES	4/4	4	110			:
Bass	Rock	2252	FA_ProgresRock1_ES	4/4	1	110			:
Bass	Rock	2253	FB_ProgresRock1_ES	4/4	1	110			:
Bass	Rock	2254	FC_ProgresRock1_ES	4/4	1	110			:
Bass	Rock	2255	BA_ProgresRock1_ES	4/4	1	110			:
Bass	Rock	2256	MA_ProgresRock2_XS	4/4	4	120			Finger Bass
Bass	Rock	2257	MB_ProgresRock2_XS	4/4	4	120			:
Bass	Rock	2258	MC_ProgresRock2_XS	4/4	4	120			:
Bass	Rock	2259	FA_ProgresRock2_XS	4/4	1	120			:
Bass	Rock	2260	FB_ProgresRock2_XS	4/4	1	120			:
Bass	Rock	2261	FC_ProgresRock2_XS	4/4	1	120			:
Bass	Rock	2262	BA_ProgresRock2_XS	4/4	1	120			:
Bass	Rock	2263	MA_ProgresRock2_ES	4/4	4	120			:
Bass	Rock	2264	MB_ProgresRock2_ES	4/4	4	120			:
Bass	Rock	2265	MC_ProgresRock2_ES	4/4	4	120			:
Bass	Rock	2266	FA_ProgresRock2_ES	4/4	1	120			:
Bass	Rock	2267	FB_ProgresRock2_ES	4/4	1	120			:
Bass	Rock	2268	FC_ProgresRock2_ES	4/4	1	120			:
Bass	Rock	2269	BA_ProgresRock2_ES	4/4	1	120			:
Bass	Rock	2270	MA_Pick Bass1_ES	4/4	4	120			Pick Bass
Bass	Rock	2271	MA_Pick Bass2_ES	4/4	4	120			:
Bass	Rock	2272	MA_Pick Bass3_ES	4/4	4	120			:
Bass	Rock	2273	MA_Pick Bass4_ES	4/4	4	120			:
Bass	Rock	2274	MA_Pick Bass5_ES	4/4	4	120			:
Bass	R&B	2275	MA_Funk 3_ES	4/4	2	132			Finger Bass
Bass	R&B	2276	MB_Funk 3_ES	4/4	2	132			:
Bass	R&B	2277	MC_Funk 3_ES	4/4	4	132			:
Bass	R&B	2278	MD_Funk 3_ES	4/4	4	132			:
Bass	R&B	2279	IA_Funk 3_ES	4/4	1	132			:
Bass	R&B	2280	FB_Funk 3_ES	4/4	1	132			:
Bass	R&B	2281	MA1_Cool Funk_ES	4/4	2	96			:
Bass	R&B	2282	MB1_Cool Funk_ES	4/4	2	96			:
Bass	R&B	2283	MC1_Cool Funk_ES	4/4	2	96			:
Bass	R&B	2284	MD1_Cool Funk_ES	4/4	4	96			:
Bass	R&B	2285	IA1_Cool Funk_ES	4/4	2	96			:
Bass	R&B	2286	FA1_Cool Funk_ES	4/4	1	96			:
Bass	R&B	2287	FB1_Cool Funk_ES	4/4	1	96			:
Bass	R&B	2288	FC1_Cool Funk_ES	4/4	1	96			:
Bass	R&B	2289	MA2_Cool Funk_ES	4/4	2	96			:
Bass	R&B	2290	MB2_Cool Funk_ES	4/4	2	96			:
Bass	R&B	2291	MC2_Cool Funk_ES	4/4	2	96			:
Bass	R&B	2292	MD2_Cool Funk_ES	4/4	4	96			:
Bass	R&B	2293	IA2_Cool Funk_ES	4/4	2	96			:
Bass	R&B	2294	FA2_Cool Funk_ES	4/4	1	96			:
Bass	R&B	2295	FB2_Cool Funk_ES	4/4	1	96			:
Bass	R&B	2296	FC2_Cool Funk_ES	4/4	1	96			:
Bass	R&B	2297	MA_Jazz Funk 2_ES	4/4	2	120			:
Bass	R&B	2298	MB_Jazz Funk 2_ES	4/4	4	120			:
Bass	R&B	2299	MC_Jazz Funk 2_ES	4/4	4	120			:
Bass	R&B	2300	MD_Jazz Funk 2_ES	4/4	4	120			:
Bass	R&B	2301	FA_Jazz Funk 2_ES	4/4	1	120			:
Bass	R&B	2302	MA_Jazz Funk 3_XS	4/4	4	123			Synth Bass
Bass	R&B	2303	MB_Jazz Funk 3_XS	4/4	4	123			:
Bass	R&B	2304	MC_Jazz Funk 3_XS	4/4	4	123			:
Bass	R&B	2305	MD_Jazz Funk 3_XS	4/4	2	123			:
Bass	R&B	2306	FA_Jazz Funk 3_ES	4/4	4	123			:
Bass	R&B	2307	MB_Jazz Funk 3_ES	4/4	4	123			:
Bass	R&B	2308	MC_Jazz Funk 3_ES	4/4	4	123			:
Bass	R&B	2309	MD_Jazz Funk 3_ES	4/4	2	123			:
Bass	R&B	2310	MA_Club Jazz 1_XS	4/4	4	125			Finger Bass
Bass	R&B	2311	MB_Club Jazz 1_XS	4/4	4	125			:
Bass	R&B	2312	MC_Club Jazz 1_XS	4/4	4	125			:
Bass	R&B	2313	FA_Club Jazz 1_XS	4/4	1	125			:
Bass	R&B	2314	FB_Club Jazz 1_XS	4/4	1	125			:
Bass	R&B	2315	FC_Club Jazz 1_XS	4/4	1	125			:
Bass	R&B	2316	BA_Club Jazz 1_XS	4/4	1	125			:
Bass	R&B	2317	MA_Club Jazz 1_ES	4/4	4	125			:
Bass	R&B	2318	MB_Club Jazz 1_ES	4/4	4	125			:

Arpeggio Type List

Main Category	Sub Category	ARP No.	ARP Name	Time Signature	Length	Original Tempo	Accent	Random SFX	Voice Type
Bass	R&B	2319	MC_Club Jazz 1_ES	4/4	4	125			Finger Bass
Bass	R&B	2320	FA_Club Jazz 1_ES	4/4	1	125			:
Bass	R&B	2321	FB_Club Jazz 1_ES	4/4	1	125			:
Bass	R&B	2322	FC_Club Jazz 1_ES	4/4	1	125			:
Bass	R&B	2323	BA_Club Jazz 1_ES	4/4	1	125			:
Bass	R&B	2324	MA_Club Jazz 2_XS	4/4	4	92			:
Bass	R&B	2325	MB_Club Jazz 2_XS	4/4	4	92			:
Bass	R&B	2326	MC_Club Jazz 2_XS	4/4	4	92			:
Bass	R&B	2327	FA_Club Jazz 2_XS	4/4	1	92			:
Bass	R&B	2328	FB_Club Jazz 2_XS	4/4	1	92			:
Bass	R&B	2329	FC_Club Jazz 2_XS	4/4	1	92			:
Bass	R&B	2330	BA_Club Jazz 2_XS	4/4	1	92			:
Bass	R&B	2331	MA_Club Jazz 2_ES	4/4	4	92			:
Bass	R&B	2332	MB_Club Jazz 2_ES	4/4	4	92			:
Bass	R&B	2333	MC_Club Jazz 2_ES	4/4	4	92			:
Bass	R&B	2334	FA_Club Jazz 2_ES	4/4	1	92			:
Bass	R&B	2335	FB_Club Jazz 2_ES	4/4	1	92			:
Bass	R&B	2336	FC_Club Jazz 2_ES	4/4	1	92			:
Bass	R&B	2337	BA_Club Jazz 2_ES	4/4	1	92			:
Bass	R&B	2338	MA_Pop Shuffle1_XS	4/4	4	94			Finger/Slap Bass
Bass	R&B	2339	MB_Pop Shuffle1_XS	4/4	4	94			:
Bass	R&B	2340	MC_Pop Shuffle1_XS	4/4	4	94			:
Bass	R&B	2341	FA_Pop Shuffle1_XS	4/4	1	94			:
Bass	R&B	2342	FB_Pop Shuffle1_XS	4/4	1	94			:
Bass	R&B	2343	FC_Pop Shuffle1_XS	4/4	1	94			:
Bass	R&B	2344	BA_Pop Shuffle1_XS	4/4	1	94			:
Bass	R&B	2345	MA_Pop Shuffle1_ES	4/4	4	94			:
Bass	R&B	2346	MB_Pop Shuffle1_ES	4/4	4	94			:
Bass	R&B	2347	MC_Pop Shuffle1_ES	4/4	4	94			:
Bass	R&B	2348	FA_Pop Shuffle1_ES	4/4	1	94			:
Bass	R&B	2349	FB_Pop Shuffle1_ES	4/4	1	94			:
Bass	R&B	2350	FC_Pop Shuffle1_ES	4/4	1	94			:
Bass	R&B	2351	BA_Pop Shuffle1_ES	4/4	1	94			:
Bass	R&B	2352	MA_Pop Shuffle2_XS	4/4	4	80			Pick Bass
Bass	R&B	2353	MB_Pop Shuffle2_XS	4/4	4	80			:
Bass	R&B	2354	MC_Pop Shuffle2_XS	4/4	4	80			:
Bass	R&B	2355	FA_Pop Shuffle2_XS	4/4	1	80			:
Bass	R&B	2356	FB_Pop Shuffle2_XS	4/4	1	80			:
Bass	R&B	2357	FC_Pop Shuffle2_XS	4/4	1	80			:
Bass	R&B	2358	BA_Pop Shuffle2_XS	4/4	1	80			:
Bass	R&B	2359	MA_Pop Shuffle2_ES	4/4	4	80			:
Bass	R&B	2360	MB_Pop Shuffle2_ES	4/4	4	80			:
Bass	R&B	2361	MC_Pop Shuffle2_ES	4/4	4	80			:
Bass	R&B	2362	FA_Pop Shuffle2_ES	4/4	1	80			:
Bass	R&B	2363	FB_Pop Shuffle2_ES	4/4	1	80			:
Bass	R&B	2364	FC_Pop Shuffle2_ES	4/4	1	80			:
Bass	R&B	2365	BA_Pop Shuffle2_ES	4/4	1	80			:
Bass	R&B	2366	MA_R&B Disco_ES	4/4	2	110			Synth Bass
Bass	R&B	2367	MB_R&B Disco_ES	4/4	2	110			:
Bass	R&B	2368	MC_R&B Disco_ES	4/4	2	110			:
Bass	R&B	2369	MD_R&B Disco_ES	4/4	2	110			:
Bass	R&B	2370	FA_R&B Disco_ES	4/4	1	110			:
Bass	R&B	2371	FB_R&B Disco_ES	4/4	1	110			:
Bass	R&B	2372	FC_R&B Disco_ES	4/4	2	110			:
Bass	R&B	2373	MA_Chart R&B_XS	4/4	4	130			:
Bass	R&B	2374	MB_Chart R&B_XS	4/4	4	130			:
Bass	R&B	2375	MC_Chart R&B_XS	4/4	4	130			:
Bass	R&B	2376	FA_Chart R&B_XS	4/4	1	130			:
Bass	R&B	2377	FB_Chart R&B_XS	4/4	1	130			:
Bass	R&B	2378	FC_Chart R&B_XS	4/4	1	130			:
Bass	R&B	2379	BA_Chart R&B_XS	4/4	1	130			:
Bass	R&B	2380	MA_ChartPop1_XS	4/4	4	92			:
Bass	R&B	2381	MB_ChartPop1_XS	4/4	4	92			:
Bass	R&B	2382	MC_ChartPop1_XS	4/4	4	92			:
Bass	R&B	2383	FA_ChartPop1_XS	4/4	1	92			:
Bass	R&B	2384	FB_ChartPop1_XS	4/4	1	92			:
Bass	R&B	2385	FC_ChartPop1_XS	4/4	1	92			:
Bass	R&B	2386	BA_ChartPop1_XS	4/4	1	92			:
Bass	R&B	2387	MA_ChartPop2_XS	4/4	2	92			:
Bass	R&B	2388	MB_ChartPop2_XS	4/4	2	92			:
Bass	R&B	2389	MC_ChartPop2_XS	4/4	2	92			:
Bass	R&B	2390	MD_ChartPop2_XS	4/4	2	92			:
Bass	R&B	2391	MA_ChartPop2_ES	4/4	2	92			:
Bass	R&B	2392	MB_ChartPop2_ES	4/4	2	92			:
Bass	R&B	2393	MC_ChartPop2_ES	4/4	2	92			:
Bass	R&B	2394	MD_ChartPop2_ES	4/4	2	92			:
Bass	R&B	2395	MA_R&B_XS	4/4	2	83			:
Bass	R&B	2396	MB_R&B_XS	4/4	2	83			:
Bass	R&B	2397	MC_R&B_XS	4/4	2	83			:
Bass	R&B	2398	FA_R&B_XS	4/4	1	83			:
Bass	R&B	2399	FB_R&B_XS	4/4	1	83			:
Bass	R&B	2400	FC_R&B_XS	4/4	1	83			:
Bass	R&B	2401	BA_R&B_XS	4/4	1	83			:

Main Category	Sub Category	ARP No.	ARP Name	Time Signature	Length	Original Tempo	Accent	Random SFX	Voice Type
Bass	R&B	2402	MA_New R&B 1_XS	4/4	2	98			Synth Bass
Bass	R&B	2403	MB_New R&B 1_XS	4/4	2	98			:
Bass	R&B	2404	MC_New R&B 1_XS	4/4	2	98			:
Bass	R&B	2405	FA_New R&B 1_XS	4/4	1	98			:
Bass	R&B	2406	FB_New R&B 1_XS	4/4	1	98			:
Bass	R&B	2407	FC_New R&B 1_XS	4/4	1	98			:
Bass	R&B	2408	BA_New R&B 1_XS	4/4	1	98			:
Bass	R&B	2409	MA_New R&B 2	4/4	1	97			:
Bass	R&B	2410	MB_New R&B 2	4/4	1	97			:
Bass	R&B	2411	MC_New R&B 2	4/4	1	97			:
Bass	R&B	2412	MD_New R&B 2	4/4	1	97			:
Bass	R&B	2413	IA_New R&B 2	4/4	2	97			:
Bass	R&B	2414	FA_New R&B 2	4/4	1	97			:
Bass	R&B	2415	FB_New R&B 2	4/4	1	97			:
Bass	R&B	2416	FC_New R&B 2	4/4	2	97			:
Bass	R&B	2417	MB_New R&B 3_ES	4/4	2	90			:
Bass	R&B	2418	MC_New R&B 3_ES	4/4	2	90			:
Bass	R&B	2419	MD_New R&B 3_ES	4/4	2	90			:
Bass	R&B	2420	IA_New R&B 3_ES	4/4	2	90			:
Bass	R&B	2421	FA_New R&B 3_ES	4/4	1	90			:
Bass	R&B	2422	FB_New R&B 3_ES	4/4	1	90			:
Bass	R&B	2423	FC_New R&B 3_ES	4/4	2	90			:
Bass	R&B	2424	MA_Pop R&B_XS	4/4	4	67			:
Bass	R&B	2425	MB_Pop R&B_XS	4/4	4	67			:
Bass	R&B	2426	MC_Pop R&B_XS	4/4	4	67			:
Bass	R&B	2427	FA_Pop R&B_XS	4/4	1	67			:
Bass	R&B	2428	FB_Pop R&B_XS	4/4	1	67			:
Bass	R&B	2429	FC_Pop R&B_XS	4/4	1	67			:
Bass	R&B	2430	BA_Pop R&B_XS	4/4	1	67			:
Bass	R&B	2431	MA_H-R&B Pop_XS	4/4	4	140			:
Bass	R&B	2432	MB_H-R&B Pop_XS	4/4	4	140			:
Bass	R&B	2433	MC_H-R&B Pop_XS	4/4	4	140			:
Bass	R&B	2434	FA_H-R&B Pop_XS	4/4	1	140			:
Bass	R&B	2435	FB_H-R&B Pop_XS	4/4	1	140			:
Bass	R&B	2436	BA_H-R&B Pop_XS	4/4	1	140			:
Bass	R&B	2437	MA_J-R&B Pop_XS	4/4	4	100			:
Bass	R&B	2438	MB_J-R&B Pop_XS	4/4	4	100			:
Bass	R&B	2439	MC_J-R&B Pop_XS	4/4	4	100			:
Bass	R&B	2440	FA_J-R&B Pop_XS	4/4	1	100			:
Bass	R&B	2441	FB_J-R&B Pop_XS	4/4	1	100			:
Bass	R&B	2442	FC_J-R&B Pop_XS	4/4	1	100			:
Bass	R&B	2443	MA_R&B Ana Pop_XS	4/4	4	95			:
Bass	R&B	2444	MB_R&B Ana Pop_XS	4/4	4	95			:
Bass	R&B	2445	MC_R&B Ana Pop_XS	4/4	4	95			:
Bass	R&B	2446	FA_R&B Ana Pop_XS	4/4	1	95			:
Bass	R&B	2447	FB_R&B Ana Pop_XS	4/4	1	95			:
Bass	R&B	2448	FC_R&B Ana Pop_XS	4/4	1	95			:
Bass	R&B	2449	BA_R&B Ana Pop_XS	4/4	1	95			:
Bass	R&B	2450	MA_R&B Ballad 1_XS	4/4	4	70			:
Bass	R&B	2451	MB_R&B Ballad 1_XS	4/4	4	70			:
Bass	R&B	2452	MC_R&B Ballad 1_XS	4/4	4	70			:
Bass	R&B	2453	FA_R&B Ballad 1_XS	4/4	1	70			:
Bass	R&B	2454	FB_R&B Ballad 1_XS	4/4	1	70			:
Bass	R&B	2455	FC_R&B Ballad 1_XS	4/4	1	70			:
Bass	R&B	2456	BA_R&B Ballad 1_XS	4/4	1	70			:
Bass	R&B	2457	MA_R&B Ballad 2_XS	4/4	2	60			:
Bass	R&B	2458	MB_R&B Ballad 2_XS	4/4	2	60			:
Bass	R&B	2459	MC_R&B Ballad 2_XS	4/4	2	60			:
Bass	R&B	2460	MD_R&B Ballad 2_XS	4/4	2	60			:
Bass	R&B	2461	MA_R&B Ballad 2_ES	4/4	2	60			:
Bass	R&B	2462	MB_R&B Ballad 2_ES	4/4	2	60			:
Bass	R&B	2463	MC_R&B Ballad 2_ES	4/4	2	60			:
Bass	R&B	2464	MD_R&B Ballad 2_ES	4/4	2	60			:
Bass	R&B	2465	MA_R&B Ballad 3_XS	4/4	4	113			:
Bass	R&B	2466	MB_R&B Ballad 3_XS	4/4	4	113			:
Bass	R&B	2467	MC_R&B Ballad 3_XS	4/4	4	113			:
Bass	R&B	2468	FA_R&B Ballad 3_XS	4/4	1	113			:
Bass	R&B	2469	FB_R&B Ballad 3_XS	4/4	1	113			:
Bass	R&B	2470	FC_R&B Ballad 3_XS	4/4	1	113			:
Bass	R&B	2471	BA_R&B Ballad 3_XS	4/4	1	113			:
Bass	R&B	2472	MA_6/8 R&B_ES	4/4	2	61			:
Bass	R&B	2473	MC_6/8 R&B_ES	4/4	2	61			:
Bass	R&B	2474	MD_6/8 R&B_ES	4/4	2	61			:
Bass	R&B	2475	FA_6/8 R&B_ES	4/4	1	61			:
Bass	R&B	2476	FB_6/8 R&B_ES	4/4	1	61			:
Bass	R&B	2477	FC_6/8 R&B_ES	4/4	2	61			:
Bass	R&B	2478	MA_Smooth 1_ES	4/4	2	115			:
Bass	R&B	2479	MB_Smooth 1_ES	4/4	2	115			:
Bass	R&B	2480	MC_Smooth 1_ES	4/4	2	115		</	

Arpeggio Type List

Main Category	Sub Category	ARP No.	ARP Name	Time Signature	Length	Original Tempo	Accent	Random SFX	Voice Type
Bass	R&B	2485	MA_Flip Hop 1_ES	4/4	2	132			Finger Bass
Bass	R&B	2486	MB_Flip Hop 1_ES	4/4	2	132			:
Bass	R&B	2487	MC_Flip Hop 1_ES	4/4	2	132			:
Bass	R&B	2488	MD_Flip Hop 1_ES	4/4	2	132			:
Bass	R&B	2489	IA_Flip Hop 1_ES	4/4	2	132			:
Bass	R&B	2490	MA_2BZ4U_XS	4/4	4	75			Synth Bass
Bass	R&B	2491	MB_2BZ4U_XS	4/4	4	75			:
Bass	R&B	2492	MC_2BZ4U_XS	4/4	4	75			:
Bass	R&B	2493	MA_2BZ4U_ES	4/4	4	75			:
Bass	R&B	2494	MB_2BZ4U_ES	4/4	4	75			:
Bass	R&B	2495	MC_2BZ4U_ES	4/4	4	75			:
Bass	R&B	2496	MA_DirtySynth_XS	4/4	4	85			:
Bass	R&B	2497	MB_DirtySynth_XS	4/4	4	85			:
Bass	R&B	2498	MC_DirtySynth_XS	4/4	4	85			:
Bass	R&B	2499	MA_DirtySynth_ES	4/4	4	85			:
Bass	R&B	2500	MB_DirtySynth_ES	4/4	4	85			:
Bass	R&B	2501	MC_DirtySynth_ES	4/4	4	85			:
Bass	R&B	2502	MA_PepRally_XS	4/4	2	75			:
Bass	R&B	2503	MB_PepRally_XS	4/4	2	75			:
Bass	R&B	2504	MC_PepRally_XS	4/4	2	75			:
Bass	R&B	2505	MD_PepRally_XS	4/4	2	75			:
Bass	R&B	2506	ME_PepRally_XS	4/4	2	75			:
Bass	R&B	2507	MA_PepRally	4/4	2	75			:
Bass	R&B	2508	MB_PepRally	4/4	2	75			:
Bass	R&B	2509	MC_PepRally	4/4	2	75			:
Bass	R&B	2510	MD_PepRally	4/4	2	75			:
Bass	R&B	2511	ME_PepRally	4/4	2	75			:
Bass	R&B	2512	MA_HipHopEpic_XS	4/4	2	85			:
Bass	R&B	2513	MB_HipHopEpic_XS	4/4	2	85			:
Bass	R&B	2514	MC_HipHopEpic_XS	4/4	2	85			:
Bass	R&B	2515	MA_HipHopEpic_ES	4/4	2	85			:
Bass	R&B	2516	MB_HipHopEpic_ES	4/4	2	85			:
Bass	R&B	2517	MC_HipHopEpic_ES	4/4	2	85			:
Bass	R&B	2518	MA_NewHip Hop_XS	4/4	2	85			:
Bass	R&B	2519	MB_NewHip Hop_XS	4/4	2	85			:
Bass	R&B	2520	MC_NewHip Hop_XS	4/4	2	85			:
Bass	R&B	2521	FA_NewHip Hop_XS	4/4	1	85			:
Bass	R&B	2522	FB_NewHip Hop_XS	4/4	1	85			:
Bass	R&B	2523	FC_NewHip Hop_XS	4/4	1	85			:
Bass	R&B	2524	BA_NewHip Hop_XS	4/4	1	85			:
Bass	R&B	2525	MA_East Coast_XS	4/4	2	103			:
Bass	R&B	2526	MB_East Coast_XS	4/4	2	103			:
Bass	R&B	2527	MC_East Coast_XS	4/4	2	103			:
Bass	R&B	2528	MD_East Coast_XS	4/4	2	103			:
Bass	R&B	2529	MA_East Coast_ES	4/4	2	103			:
Bass	R&B	2530	MB_East Coast_ES	4/4	2	103			:
Bass	R&B	2531	MC_East Coast_ES	4/4	2	103			:
Bass	R&B	2532	MD_East Coast_ES	4/4	2	103			:
Bass	R&B	2533	MA_West Coast_XS	4/4	2	97			:
Bass	R&B	2534	MB_West Coast_XS	4/4	2	97			:
Bass	R&B	2535	MC_West Coast_XS	4/4	2	97			:
Bass	R&B	2536	MD_West Coast_XS	4/4	2	97			:
Bass	R&B	2537	MA_West Coast_ES	4/4	2	97			:
Bass	R&B	2538	MB_West Coast_ES	4/4	2	97			:
Bass	R&B	2539	MC_West Coast_ES	4/4	2	97			:
Bass	R&B	2540	MD_West Coast_ES	4/4	2	97			:
Bass	R&B	2541	MA_South Rap 1_XS	4/4	4	98			:
Bass	R&B	2542	MB_South Rap 1_XS	4/4	4	98			:
Bass	R&B	2543	MC_South Rap 1_XS	4/4	4	98			:
Bass	R&B	2544	MD_South Rap 1_XS	4/4	4	98			:
Bass	R&B	2545	MA_South Rap 1_ES	4/4	4	98			:
Bass	R&B	2546	MB_South Rap 1_ES	4/4	4	98			:
Bass	R&B	2547	MC_South Rap 1_ES	4/4	4	98			:
Bass	R&B	2548	MD_South Rap 1_ES	4/4	4	98			:
Bass	R&B	2549	MA_South Rap 2_XS	4/4	2	90			:
Bass	R&B	2550	MB_South Rap 2_XS	4/4	2	90			:
Bass	R&B	2551	MC_South Rap 2_XS	4/4	2	90			:
Bass	R&B	2552	MD_South Rap 2_XS	4/4	2	90			:
Bass	R&B	2553	MA_South Rap 2_ES	4/4	2	90			:
Bass	R&B	2554	MB_South Rap 2_ES	4/4	2	90			:
Bass	R&B	2555	MC_South Rap 2_ES	4/4	2	90			:
Bass	R&B	2556	MD_South Rap 2_ES	4/4	2	90			:
Bass	R&B	2557	MA_Hip Hop 1_ES	4/4	2	105			:
Bass	R&B	2558	MB_Hip Hop 1_ES	4/4	2	105			:
Bass	R&B	2559	MC_Hip Hop 1_ES	4/4	2	105			:
Bass	R&B	2560	MD_Hip Hop 1_ES	4/4	2	105			:
Bass	R&B	2561	FA_Hip Hop 1_ES	4/4	1	105			:
Bass	R&B	2562	FB_Hip Hop 1_ES	4/4	1	105			:
Bass	R&B	2563	FC_Hip Hop 1_ES	4/4	2	105			:
Bass	R&B	2564	MA_Hip Hop 2	4/4	2	94			:
Bass	R&B	2565	MB_Hip Hop 2	4/4	2	94			:
Bass	R&B	2566	MC_Hip Hop 2	4/4	2	94			:
Bass	R&B	2567	MD_Hip Hop 2_ES	4/4	2	94			:

Main Category	Sub Category	ARP No.	ARP Name	Time Signature	Length	Original Tempo	Accent	Random SFX	Voice Type
Bass	R&B	2568	FA_Hip Hop 2	4/4	1	94			Synth Bass
Bass	R&B	2569	FB_Hip Hop 2_ES	4/4	1	94			:
Bass	R&B	2570	FC_Hip Hop 2_ES	4/4	2	94			:
Bass	R&B	2571	MA_Hip Hop 3_ES	4/4	2	104			:
Bass	R&B	2572	MB_Hip Hop 3_ES	4/4	2	104			:
Bass	R&B	2573	MC_Hip Hop 3_ES	4/4	2	104			:
Bass	R&B	2574	MD_Hip Hop 3_ES	4/4	2	104			:
Bass	R&B	2575	FC_Hip Hop 3_ES	4/4	2	104			:
Bass	R&B	2576	MA_Hip Hop 5_XS	4/4	2	103			:
Bass	R&B	2577	MB_Hip Hop 5_XS	4/4	4	103			:
Bass	R&B	2578	MC_Hip Hop 5_XS	4/4	2	103			:
Bass	R&B	2579	MD_Hip Hop 5_XS	4/4	2	103			:
Bass	R&B	2580	MA_Hip Hop 5_ES	4/4	2	103			:
Bass	R&B	2581	MB_Hip Hop 5_ES	4/4	4	103			:
Bass	R&B	2582	MC_Hip Hop 5_ES	4/4	2	103			:
Bass	R&B	2583	MD_Hip Hop 5_ES	4/4	2	103			:
Bass	R&B	2584	MA_Hip Hop 6_XS	4/4	4	96			:
Bass	R&B	2585	MB_Hip Hop 6_XS	4/4	4	96			:
Bass	R&B	2586	MC_Hip Hop 6_XS	4/4	4	96			:
Bass	R&B	2587	FA_Hip Hop 6_XS	4/4	1	96			:
Bass	R&B	2588	FB_Hip Hop 6_XS	4/4	1	96			:
Bass	R&B	2589	FC_Hip Hop 6_XS	4/4	1	96			:
Bass	R&B	2590	BA_Hip Hop 6_XS	4/4	1	96			:
Bass	R&B	2591	MA_Hip Break_XS	4/4	4	98			:
Bass	R&B	2592	MB_Hip Break_XS	4/4	4	98			:
Bass	R&B	2593	MC_Hip Break_XS	4/4	4	98			:
Bass	R&B	2594	FA_Hip Break_XS	4/4	1	98			:
Bass	R&B	2595	FB_Hip Break_XS	4/4	1	98			:
Bass	R&B	2596	FC_Hip Break_XS	4/4	1	98			:
Bass	R&B	2597	BA_Hip Break_XS	4/4	1	98			:
Bass	R&B	2598	MA_Hip Rock 1_XS	4/4	4	90			:
Bass	R&B	2599	MB_Hip Rock 1_XS	4/4	4	90			:
Bass	R&B	2600	MC_Hip Rock 1_XS	4/4	4	90			:
Bass	R&B	2601	FA_Hip Rock 1_XS	4/4	1	90			:
Bass	R&B	2602	FB_Hip Rock 1_XS	4/4	1	90			:
Bass	R&B	2603	MA_Hip Rock 2_XS	4/4	4	132			Finger Bass
Bass	R&B	2604	MB_Hip Rock 2_XS	4/4	4	132			:
Bass	R&B	2605	MC_Hip Rock 2_XS	4/4	4	132			:
Bass	R&B	2606	FA_Hip Rock 2_XS	4/4	1	132			:
Bass	R&B	2607	FB_Hip Rock 2_XS	4/4	1	132			:
Bass	R&B	2608	FC_Hip Rock 2_XS	4/4	1	132			:
Bass	R&B	2609	BA_Hip Rock 2_XS	4/4	1	132			:
Bass	R&B	2610	MA_Hip Reggae_XS	4/4	4	92			Synth Bass
Bass	R&B	2611	MB_Hip Reggae_XS	4/4	4	92			:
Bass	R&B	2612	MC_Hip Reggae_XS	4/4	4	92			:
Bass	R&B	2613	FA_Hip Reggae_XS	4/4	1	92			:
Bass	R&B	2614	FB_Hip Reggae_XS	4/4	1	92			:
Bass	R&B	2615	FC_Hip Reggae_XS	4/4	1	92			:
Bass	R&B	2616	MA_Regeton_XS	4/4	4	98			:
Bass	R&B	2617	MB_Regeton_XS	4/4	4	98			:
Bass	R&B	2618	MC_Regeton_XS	4/4	4	98			:
Bass	R&B	2619	FA_Regeton_XS	4/4	1	98			:
Bass	R&B	2620	FB_Regeton_XS	4/4	1	98			:
Bass	R&B	2621	FC_Regeton_XS	4/4	1	98			:
Bass	R&B	2622	BA_Regeton_XS	4/4	1	98			:
Bass	R&B	2623	MA_ClasticHipHop_ES	4/4	2	90			:
Bass	R&B	2624	MB_ClasticHipHop_ES	4/4	2	90			:
Bass	R&B	2625	MC_ClasticHipHop_ES	4/4	2	90			:
Bass	R&B	2626	MD_ClasticHipHop_ES	4/4	2	90			:
Bass	R&B	2627	FA_ClasticHipHop_ES	4/4	1	90			:
Bass	R&B	2628	MA_Soul 2_ES	4/4	4	120			Finger Bass
Bass	R&B	2629	MB_Soul 2_ES	4/4	1	120			:
Bass	R&B	2630	MC_Soul 2_ES	4/4	4	120			:
Bass	R&B	2631	MD_Soul 2_ES	4/4	4	120			:
Bass	R&B	2632	MA_Soul 3_XS	4/4	4	88			Synth Bass
Bass	R&B	2633	MB_Soul 3_XS	4/4	4	88			:
Bass	R&B	2634	MC_Soul 3_XS	4/4	4	88			:
Bass	R&B	2635	MD_Soul 3_XS	4/4	4	88			:
Bass	R&B	2636	MA_Soul 3_ES	4/4	4	88			:
Bass	R&B	2637	MB_Soul 3_ES	4/4	4	88			:
Bass	R&B	2638	MC_Soul 3_ES	4/4	4	88			:
Bass	R&B	2639	MD_Soul 3_ES	4/4	4	88			:
Bass	R&B	2640	MA_Soul Beat_XS	4/4	4	124			Finger Bass
Bass	R&B	2641	MB_Soul Beat_XS	4/4	4	124			:
Bass	R&B	2642	MC_Soul Beat_XS	4/4	4	124			:
Bass	R&B	2643	FA_Soul Beat_XS	4/4	1	124			:
Bass	R&B	2644	FB_Soul Beat_XS	4/4	1	124			:
Bass	R&B	2645	FC_Soul Beat_XS	4/4	1	124			:
Bass	R&B	2646	BA_Soul Beat_XS	4/4	1	124			:
Bass	R&B	2647	MA_New Gospel_ES	4/4	2	90			Synth Bass
Bass	R&B	2648	MB_New Gospel_ES	4/4	2	90			:
Bass	R&B	2649	MC_New Gospel_ES	4/4	2	90			:
Bass									

Main Category	Sub Category	ARP No.	ARP Name	Time Signature	Length	Original Tempo	Accent	Random SFX	Voice Type
Bass	R&B	2651	FA_New Gospel_ES	4/4	1	90			Synth Bass
Bass	R&B	2652	FC_New Gospel_ES	4/4	2	90			:
Bass	R&B	2653	MA_FingerBass1_ES	4/4	1	115			Finger Bass
Bass	R&B	2654	MA_FingerBass2_ES	4/4	1	115			:
Bass	R&B	2655	MA_FingerBass3_ES	4/4	3	115			:
Bass	R&B	2656	MA_FingerBass4_ES	4/4	1	115			:
Bass	R&B	2657	MA_FingerBass5_ES	4/4	1	115			:
Bass	R&B	2658	MA_FingerBass6_ES	4/4	1	115			:
Bass	R&B	2659	MA_FingerBass7_ES	4/4	2	120			:
Bass	R&B	2660	MA_FingerBass8_ES	4/4	2	150			:
Bass	R&B	2661	MA_FingerBass9_ES	4/4	2	150			:
Bass	R&B	2662	MA_FingerBass10_ES	4/4	2	89			:
Bass	R&B	2663	MA_FingerBass11_ES	4/4	2	89			:
Bass	R&B	2664	MA_FingerBass12_ES	4/4	1	115			:
Bass	R&B	2665	MA_FingerBass13_ES	4/4	1	115			:
Bass	R&B	2666	MA_FingerBass14_ES	4/4	1	115			:
Bass	R&B	2667	MA_FingerBass15_ES	4/4	4	107			:
Bass	R&B	2668	MA_FingerBass16_ES	4/4	4	107			:
Bass	R&B	2669	MA_FingerBass17_ES	4/4	4	107			:
Bass	R&B	2670	MA_FingerBass18_ES	4/4	4	107			:
Bass	R&B	2671	MA_FingerBass19_ES	4/4	4	107			:
Bass	R&B	2672	MA_Slap Bass1	4/4	4	120			Slap Bass
Bass	R&B	2673	MA_Slap Bass2	4/4	2	120			:
Bass	R&B	2674	MA_Slap Bass3_ES	4/4	1	124			:
Bass	R&B	2675	MA_Slap Bass4_ES	4/4	1	124			:
Bass	R&B	2676	MA_Slap Bass5_ES	4/4	2	124			:
Bass	R&B	2677	MA_Slap Bass6_ES	4/4	1	105			:
Bass	R&B	2678	MA_Slap Bass7_ES	4/4	1	105			:
Bass	R&B	2679	MA_Slap Bass8_ES	4/4	1	105			:
Bass	R&B	2680	MA_Slap Bass9_ES	4/4	2	110			:
Bass	R&B	2681	MA_Slap Bass10_ES	4/4	1	110			:
Bass	R&B	2682	MA_Slap Bass11_ES	4/4	1	90			:
Bass	R&B	2683	MA_Slap Bass12_ES	4/4	3	120			:
Bass	R&B	2684	MA_Slap Bass13_ES	4/4	1	120			:
Bass	R&B	2685	MA_ElectroHipBs	4/4	4	70			Synth Bass
Bass	R&B	2686	MA_Grubbass	4/4	2	120			:
Bass	Elect	2687	MA_Ambient1_XS	4/4	4	102			:
Bass	Elect	2688	MB_Ambient1_XS	4/4	4	102			:
Bass	Elect	2689	MC_Ambient1_XS	4/4	4	102			:
Bass	Elect	2690	FB_Ambient1_XS	4/4	1	102			:
Bass	Elect	2691	FC_Ambient1_XS	4/4	1	102			:
Bass	Elect	2692	MA_Ambient1_ES	4/4	4	102			:
Bass	Elect	2693	MB_Ambient1_ES	4/4	4	102			:
Bass	Elect	2694	MC_Ambient1_ES	4/4	4	102			:
Bass	Elect	2695	FB_Ambient1_ES	4/4	1	102			:
Bass	Elect	2696	FC_Ambient1_ES	4/4	1	102			:
Bass	Elect	2697	MA_Ambient2_XS	4/4	4	111			:
Bass	Elect	2698	MB_Ambient2_XS	4/4	2	111			:
Bass	Elect	2699	MC_Ambient2_XS	4/4	4	111			:
Bass	Elect	2700	FA_Ambient2_XS	4/4	1	111			:
Bass	Elect	2701	FB_Ambient2_XS	4/4	8	111			:
Bass	Elect	2702	FC_Ambient2_XS	4/4	1	111			:
Bass	Elect	2703	BA_Ambient2_XS	4/4	2	111			:
Bass	Elect	2704	MA_Ambient2_ES	4/4	4	111			:
Bass	Elect	2705	MB_Ambient2_ES	4/4	2	111			:
Bass	Elect	2706	MC_Ambient2_ES	4/4	4	111			:
Bass	Elect	2707	FA_Ambient2_ES	4/4	1	111			:
Bass	Elect	2708	FB_Ambient2_ES	4/4	8	111			:
Bass	Elect	2709	FC_Ambient2_ES	4/4	1	111			:
Bass	Elect	2710	BA_Ambient2_ES	4/4	2	111			:
Bass	Elect	2711	MB_Chill Out_ES	4/4	2	79			:
Bass	Elect	2712	MC_Chill Out_ES	4/4	4	79			:
Bass	Elect	2713	MD_Chill Out_ES	4/4	1	79			Finger Bass
Bass	Elect	2714	IA_Chill Out_ES	4/4	3	79			:
Bass	Elect	2715	FA_Chill Out_ES	4/4	1	79			Finger Bass (PB Range=12)
Bass	Elect	2716	FC_Chill Out_ES	4/4	4	79			Finger Bass
Bass	Elect	2717	MA_ChillKitBass	4/4	4	70			Synth Bass
Bass	Elect	2718	MA_ClubTechBas1	4/4	1	70			:
Bass	Elect	2719	MA_ClubTechBas2	4/4	1	70			:
Bass	Elect	2720	MA_ClubTechBas3	4/4	1	70			:
Bass	Elect	2721	MA_HeavyChillBs	4/4	4	70			:
Bass	Elect	2722	MA_HeartbreakBs	4/4	4	70			:
Bass	Elect	2723	MA_PopBreaksBas	4/4	4	70			:
Bass	Elect	2724	MB_Synth Pop_ES	4/4	2	90			Finger Bass
Bass	Elect	2725	MD_Synth Pop_ES	4/4	2	90			Synth Bass
Bass	Elect	2726	FC_Synth Pop_ES	4/4	2	90			:
Bass	Elect	2727	MA_Big Beat 1_ES	4/4	4	115			Finger Bass
Bass	Elect	2728	MB_Big Beat 1_ES	4/4	4	115			:
Bass	Elect	2729	MC_Big Beat 1_ES	4/4	4	115			:
Bass	Elect	2730	FA_Big Beat 1_ES	4/4	1	115			:
Bass	Elect	2731	FB_Big Beat 1_ES	4/4	1	115			:
Bass	Elect	2732	FC_Big Beat 1_ES	4/4	1	115			:
Bass	Elect	2733	BA_Big Beat 1_ES	4/4	1	115			:

Main Category	Sub Category	ARP No.	ARP Name	Time Signature	Length	Original Tempo	Accent	Random SFX	Voice Type
Bass	Elect	2734	MA_Breakbeats 1_ES	4/4	4	115			Synth Bass
Bass	Elect	2735	MB_Breakbeats 1_ES	4/4	4	115			:
Bass	Elect	2736	MC_Breakbeats 1_ES	4/4	2	115			:
Bass	Elect	2737	FA_Breakbeats 1_ES	4/4	1	115			:
Bass	Elect	2738	FB_Breakbeats 1_ES	4/4	1	115			:
Bass	Elect	2739	FC_Breakbeats 1_ES	4/4	1	115			:
Bass	Elect	2740	BA_Breakbeats 1_ES	4/4	1	115			:
Bass	Elect	2741	MA_Breakbeats 2_ES	4/4	4	88			:
Bass	Elect	2742	MB_Breakbeats 2_ES	4/4	4	88			:
Bass	Elect	2743	MC_Breakbeats 2_ES	4/4	4	88			:
Bass	Elect	2744	FA_Breakbeats 2_ES	4/4	1	88			:
Bass	Elect	2745	FB_Breakbeats 2_ES	4/4	1	88			:
Bass	Elect	2746	FC_Breakbeats 2_ES	4/4	1	88			:
Bass	Elect	2747	BA_Breakbeats 2_ES	4/4	1	88			:
Bass	Elect	2748	MA_Techno 1_ES	4/4	4	135			:
Bass	Elect	2749	MB_Techno 1_ES	4/4	8	135			:
Bass	Elect	2750	MC_Techno 1_ES	4/4	8	135			:
Bass	Elect	2751	FA_Techno 1_ES	4/4	1	135			:
Bass	Elect	2752	FB_Techno 1_ES	4/4	1	135			:
Bass	Elect	2753	FC_Techno 1_ES	4/4	1	135			:
Bass	Elect	2754	BA_Techno 1_ES	4/4	3	135			:
Bass	Elect	2755	MB_Techno 2_ES	4/4	4	137			Finger Bass
Bass	Elect	2756	MC_Techno 2_ES	4/4	4	137			Synth Bass
Bass	Elect	2757	FA_Techno 2_ES	4/4	1	137			:
Bass	Elect	2758	FB_Techno 2_ES	4/4	2	137			Finger Bass
Bass	Elect	2759	BA_Techno 2_ES	4/4	4	137			Synth Bass
Bass	Elect	2760	MA_Trance 1_XS	4/4	8	142			:
Bass	Elect	2761	MB_Trance 1_XS	4/4	4	142			:
Bass	Elect	2762	MC_Trance 1_XS	4/4	16	142			:
Bass	Elect	2763	FA_Trance 1_XS	4/4	2	142			:
Bass	Elect	2764	FB_Trance 1_XS	4/4	8	142			:
Bass	Elect	2765	FC_Trance 1_XS	4/4	8	142			:
Bass	Elect	2766	MA_Trance 1_ES	4/4	8	142			:
Bass	Elect	2767	MB_Trance 1_ES	4/4	4	142			:
Bass	Elect	2768	MC_Trance 1_ES	4/4	16	142			:
Bass	Elect	2769	FA_Trance 1_ES	4/4	2	142			:
Bass	Elect	2770	FB_Trance 1_ES	4/4	8	142			:
Bass	Elect	2771	FC_Trance 1_ES	4/4	8	142			:
Bass	Elect	2772	MA_Trance 2_XS	4/4	8	135			:
Bass	Elect	2773	MB_Trance 2_XS	4/4	8	135			:
Bass	Elect	2774	MC_Trance 2_XS	4/4	8	135			:
Bass	Elect	2775	FA_Trance 2_XS	4/4	1	135			:
Bass	Elect	2776	FB_Trance 2_XS	4/4	8	135			:
Bass	Elect	2777	FC_Trance 2_XS	4/4	1	135			:
Bass	Elect	2778	BA_Trance 2_XS	4/4	1	135			:
Bass	Elect	2779	MA_Trance 2_ES	4/4	8	135			:
Bass	Elect	2780	MB_Trance 2_ES	4/4	8	135			:
Bass	Elect	2781	MC_Trance 2_ES	4/4	8	135			:
Bass	Elect	2782	FA_Trance 2_ES	4/4	1	135			:
Bass	Elect	2783	FB_Trance 2_ES	4/4	8	135			:
Bass	Elect	2784	FC_Trance 2_ES	4/4	1	135			:
Bass	Elect	2785	BA_Trance 2_ES	4/4	1	135			:
Bass	Elect	2786	MA_Trance 3_XS	4/4	2	140			:
Bass	Elect	2787	MB_Trance 3_XS	4/4	2	140			:
Bass	Elect	2788	MC_Trance 3_XS	4/4	3	140			:
Bass	Elect	2789	FA_Trance 3_XS	4/4	2	140			:
Bass	Elect	2790	FB_Trance 3_XS	4/4	2	140			:
Bass	Elect	2791	FC_Trance 3_XS	4/4	4	140			:
Bass	Elect	2792	BA_Trance 3_XS	4/4	1	140			:
Bass	Elect	2793	MA_Trance 3_ES	4/4	2	140			:
Bass	Elect	2794	MB_Trance 3_ES	4/4	2	140			:
Bass	Elect	2795	MC_Trance 3_ES	4/4	3	140			:
Bass	Elect	2796	FA_Trance 3_ES	4/4	2	140			:
Bass	Elect	2797	FB_Trance 3_ES	4/4	2	140			:
Bass	Elect	2798	FC_Trance 3_ES	4/4	4	140			:
Bass	Elect	2799	BA_Trance 3_ES	4/4	1	140			:
Bass	Elect	2800	MA_Trance 4_XS	4/4	4	130			:
Bass	Elect	2801	MB_Trance 4_XS	4/4	2	130			:
Bass	Elect	2802	MC_Trance 4_XS	4/4	4	130			:
Bass	Elect	2803	FA_Trance 4_XS	4/4	4	130			:
Bass	Elect	2804	FB_Trance 4_XS	4/4	2	130			:
Bass	Elect	2805	FC_Trance 4_XS	4/4	4	130			:
Bass	Elect	2806	BA_Trance 4_XS	4/4	2	130			:
Bass	Elect	2807	MA_Trance 4_ES	4/4	4	130			:
Bass	Elect	2808	MB_Trance 4_ES	4/4	2	130			:
Bass	Elect	2809	MC_Trance 4_ES	4/4	4	130			:
Bass	Elect	2810	FA_Trance 4_ES	4/4	4	130			:
Bass	Elect	2811	FB_Trance 4_ES	4/4	2	130			:
Bass	Elect	2812	FC_Trance 4_ES	4/4	4	130			:
Bass	Elect	2813	BA_Trance 4_ES	4/4	2	130			:
Bass	Elect	2814	MA_Trance 5_ES	4/4	1	140			:
Bass	Elect	2815	FA_Trance 5_ES	4/4	1	140			:
Bass	Elect	2816	FC_Trance 5_ES	4/4	4	140			:

Arpeggio Type List

Main Category	Sub Category	ARP No.	ARP Name	Time Signature	Length	Original Tempo	Accent	Random SFX	Voice Type
Bass	Elect	2817	MA_TranceBassA1_ES	4/4	2	143			Synth Bass
Bass	Elect	2818	MA_TranceBassA2_ES	4/4	1	143			:
Bass	Elect	2819	MA_TranceBassA3_ES	4/4	1	143			:
Bass	Elect	2820	MA_TranceBassA4_ES	4/4	1	143			:
Bass	Elect	2821	MA_TranceBassA5_ES	4/4	1	143			:
Bass	Elect	2822	MA_TranceBassB1	4/4	1	143			:
Bass	Elect	2823	MA_TranceBassB2_ES	4/4	1	143			:
Bass	Elect	2824	MA_TranceBassB3_ES	4/4	1	143			:
Bass	Elect	2825	MA_TranceBassB4_ES	4/4	1	143			:
Bass	Elect	2826	MA_TranceBassB5_ES	4/4	1	143			:
Bass	Elect	2827	MA_Noise Xpress	4/4	4	70			:
Bass	Elect	2828	MA_Tek Bass1	4/4	1	138			:
Bass	Elect	2829	MA_Tek Bass2	4/4	1	138			:
Bass	Elect	2830	MA_Tek Bass3	4/4	8	138			:
Bass	Elect	2831	MA_Dream Dance_ES	4/4	2	136			:
Bass	Elect	2832	MB_Dream Dance_ES	4/4	1	136			:
Bass	Elect	2833	MC_Dream Dance_ES	4/4	4	136			:
Bass	Elect	2834	MD_Dream Dance_ES	4/4	4	136			:
Bass	Elect	2835	FA_Dream Dance_ES	4/4	1	136			:
Bass	Elect	2836	MA_Ibiza_ES	4/4	2	135			:
Bass	Elect	2837	MB_Ibiza_ES	4/4	2	135			:
Bass	Elect	2838	MC_Ibiza_ES	4/4	2	135			:
Bass	Elect	2839	MD_Ibiza_ES	4/4	2	135			:
Bass	Elect	2840	IA_Ibiza_ES	4/4	1	135			:
Bass	Elect	2841	FC_Ibiza_ES	4/4	4	135			:
Bass	Elect	2842	MA_Retro Pop_ES	4/4	2	126			:
Bass	Elect	2843	MA_Disco House_XS	4/4	4	126			:
Bass	Elect	2844	MB_Disco House_XS	4/4	4	126			:
Bass	Elect	2845	MC_Disco House_XS	4/4	4	126			:
Bass	Elect	2846	FA_Disco House_XS	4/4	1	126			:
Bass	Elect	2847	FB_Disco House_XS	4/4	1	126			:
Bass	Elect	2848	FC_Disco House_XS	4/4	1	126			:
Bass	Elect	2849	BA_Disco House_XS	4/4	1	126			:
Bass	Elect	2850	MA_Club House_ES	4/4	1	128			:
Bass	Elect	2851	MB_Club House_ES	4/4	1	128			:
Bass	Elect	2852	MC_Club House_ES	4/4	1	128			:
Bass	Elect	2853	MD_Club House_ES	4/4	1	128			:
Bass	Elect	2854	IA_Club House_ES	4/4	1	128			:
Bass	Elect	2855	FA_Club House_ES	4/4	1	128			:
Bass	Elect	2856	FB_Club House_ES	4/4	1	128			:
Bass	Elect	2857	MA_Garage 2_ES	4/4	2	127			:
Bass	Elect	2858	MB_Garage 2_ES	4/4	2	127			:
Bass	Elect	2859	MC_Garage 2_ES	4/4	2	127			:
Bass	Elect	2860	MD_Garage 2_ES	4/4	2	127			:
Bass	Elect	2861	IA_Garage 2_ES	4/4	2	127			:
Bass	Elect	2862	FC_Garage 2_ES	4/4	2	127			:
Bass	Elect	2863	MA_House Bass_ES	4/4	4	120			:
Bass	Elect	2864	MA_Acid Bass1	4/4	1	86			:
Bass	Elect	2865	MA_Acid Bass2	4/4	1	120			:
Bass	Elect	2866	MA_Acid Flux	4/4	1	130			:
Bass	Elect	2867	MA_Octaver	4/4	1	120			:
Bass	Elect	2868	MA_Twister	4/4	1	135			:
Bass	Elect	2869	MA_Cyborg	4/4	1	90			:
Bass	Elect	2870	MA_LoRidr	4/4	1	90			:
Bass	Elect	2871	MA_Kronic	4/4	1	100			:
Bass	Elect	2872	MA_Triplet	4/4	1	120			:
Bass	Elect	2873	MA_Tronica	4/4	1	120			:
Bass	Elect	2874	MA_Wazzo	4/4	1	94			:
Bass	Elect	2875	MA_Swing Bass	4/4	2	132			:
Bass	Elect	2876	MA_Synth Bass1_ES	4/4	1	120			:
Bass	Elect	2877	MA_Synth Bass2_ES	4/4	1	120			:
Bass	Elect	2878	MA_Synth Bass3_ES	4/4	1	120			:
Bass	Elect	2879	MA_Synth Bass4_ES	4/4	1	120			:
Bass	Elect	2880	MA_Synth Bass5_ES	4/4	1	120			:
Bass	Jazz	2881	MA_AcousticJazz/1_ES	4/4	4	204			Acoustic Bass
Bass	Jazz	2882	MA_AcousticJazz/2_ES	4/4	4	204			:
Bass	Jazz	2883	MA_AcousticJazz/3_ES	4/4	4	204			:
Bass	Jazz	2884	MA_AcousticJazz/4_ES	4/4	4	204			:
Bass	Jazz	2885	MB_AcousticJazz/1_ES	4/4	4	204			:
Bass	Jazz	2886	MB_AcousticJazz/2_ES	4/4	4	204			:
Bass	Jazz	2887	MB_AcousticJazz/3_ES	4/4	4	204			:
Bass	Jazz	2888	MB_AcousticJazz/4_ES	4/4	4	204			:
Bass	Jazz	2889	MC_AcousticJazz/1_ES	4/4	4	204			:
Bass	Jazz	2890	MC_AcousticJazz/2_ES	4/4	4	204			:
Bass	Jazz	2891	MC_AcousticJazz/3_ES	4/4	4	204			:
Bass	Jazz	2892	MC_AcousticJazz/4_ES	4/4	4	204			:
Bass	Jazz	2893	MD_AcousticJazz/1_ES	4/4	4	204			:
Bass	Jazz	2894	MD_AcousticJazz/2_ES	4/4	4	204			:
Bass	Jazz	2895	MD_AcousticJazz/3_ES	4/4	4	204			:
Bass	Jazz	2896	MD_AcousticJazz/4_ES	4/4	4	204			:
Bass	Jazz	2897	IA_AcousticJazz_ES	4/4	4	204			:
Bass	Jazz	2898	FA_AcousticJazz_ES	4/4	1	204			:
Bass	Jazz	2899	FB_AcousticJazz_ES	4/4	1	204			:

Main Category	Sub Category	ARP No.	ARP Name	Time Signature	Length	Original Tempo	Accent	Random SFX	Voice Type
Bass	Jazz	2900	FC_AcousticJazz_ES	4/4	4	204			Acoustic Bass
Bass	Jazz	2901	MA_AcousticBas1_ES	4/4	4	132			:
Bass	Jazz	2902	MA_AcousticBas2_ES	4/4	4	132			:
Bass	Jazz	2903	MA_AcousticBas3_ES	4/4	4	132			:
Bass	Jazz	2904	MA_AcousticBas4_ES	4/4	8	132			:
Bass	Jazz	2905	MA_AcousticBas5_ES	4/4	4	132			:
Bass	Jazz	2906	MA_Walkin	4/4	3	103			:
Bass	Jazz	2907	MA_Slow Blues 2_XS	4/4	4	72			Finger Bass
Bass	Jazz	2908	MB_Slow Blues 2_XS	4/4	4	72			:
Bass	Jazz	2909	MC_Slow Blues 2_XS	4/4	4	72			:
Bass	Jazz	2910	FA_Slow Blues 2_XS	4/4	1	72			:
Bass	Jazz	2911	FB_Slow Blues 2_XS	4/4	1	72			:
Bass	Jazz	2912	FC_Slow Blues 2_XS	4/4	1	72			:
Bass	Jazz	2913	BA_Slow Blues 2_XS	4/4	1	72			:
Bass	Jazz	2914	MA_Slow Blues 2_ES	4/4	4	72			:
Bass	Jazz	2915	MB_Slow Blues 2_ES	4/4	4	72			:
Bass	Jazz	2916	MC_Slow Blues 2_ES	4/4	4	72			:
Bass	Jazz	2917	FA_Slow Blues 2_ES	4/4	1	72			:
Bass	Jazz	2918	FB_Slow Blues 2_ES	4/4	1	72			:
Bass	Jazz	2919	FC_Slow Blues 2_ES	4/4	1	72			:
Bass	Jazz	2920	BA_Slow Blues 2	4/4	1	72			:
Bass	World	2921	MA_Jumbo Reggae_XS	4/4	4	100			Synth Bass
Bass	World	2922	MB_Jumbo Reggae_XS	4/4	4	100			:
Bass	World	2923	MC_Jumbo Reggae_XS	4/4	4	100			:
Bass	World	2924	FA_Jumbo Reggae_XS	4/4	1	100			:
Bass	World	2925	FB_Jumbo Reggae_XS	4/4	1	100			:
Bass	World	2926	FC_Jumbo Reggae_XS	4/4	1	100			:
Bass	World	2927	BA_Jumbo Reggae_XS	4/4	1	100			:
Bass	World	2928	MA_Reggae 1	4/4	4	102			Finger Bass
Bass	World	2929	MB_Reggae 1	4/4	4	102			:
Bass	World	2930	MC_Reggae 1	4/4	4	80			:
Bass	World	2931	MD_Reggae 1	4/4	4	90			:
Bass	World	2932	IA_Reggae 1	4/4	4	102			:
Bass	World	2933	FA_Reggae 1	4/4	1	96			:
Bass	World	2934	FB_Reggae 1	4/4	1	90			:
Bass	World	2935	FC_Reggae 1	4/4	4	96			:
Bass	World	2936	MA_Reggae 2_ES	4/4	2	92			:
Bass	World	2937	MB_Reggae 2_ES	4/4	2	92			:
Bass	World	2938	MC_Reggae 2_ES	4/4	2	92			:
Bass	World	2939	MD_Reggae 2_ES	4/4	2	92			:
Bass	World	2940	IA_Reggae 2_ES	4/4	2	92			:
Bass	World	2941	FA_Reggae 2_ES	4/4	1	92			:
Bass	World	2942	FB_Reggae 2_ES	4/4	1	92			:
Bass	World	2943	MA_Salsa 2_ES	4/4	4	123			Acoustic Bass
Bass	World	2944	MB_Salsa 2_ES	4/4	4	123			:
Bass	World	2945	FA_Salsa 2_ES	4/4	1	123			:
Bass	World	2946	FC_Salsa 2_ES	4/4	2	123			:
Bass	World	2947	MA_Montuno_ES	4/4	4	100			Finger Bass
Bass	World	2948	MC_Montuno/1_ES	4/4	4	100			:
Bass	World	2949	MD_Montuno/2_ES	4/4	4	100			:
Bass	World	2950	MD_Montuno/1_ES	4/4	4	100			:
Bass	World	2951	MD_Montuno/2_ES	4/4	4	100			:
Bass	World	2952	MD_Montuno/3_ES	4/4	4	100			:
Bass	World	2953	MD_Montuno/4_ES	4/4	4	100			:
Bass	World	2954	FA_Montuno/1_ES	4/4	1	100			:
Bass	World	2955	FA_Montuno/2_ES	4/4	1	100			:
Bass	World	2956	FC_Montuno_ES	4/4	4	100			:
Bass	World	2957	MA_Samba_ES	4/4	2	120			:
Bass	World	2958	MC_Samba_ES	4/4	4	120			:
Bass	World	2959	MD_Samba_ES	4/4	4	120			:
Bass	World	2960	IA_Samba_ES	4/4	2	120			:
Bass	World	2961	MA_FretlessBas1_ES	4/4	4	124			Fretless Bass
Bass	World	2962	MA_FretlessBas2_ES	4/4	4	124			:
Bass	World	2963	MA_FretlessBas3_ES	4/4	4	124			:
Bass	World	2964	MA_FretlessBas4_ES	4/4	4	124			:
Bass	World	2965	MA_FretlessBas5_ES	4/4	4	124			:
Bass	World	2966	MA_Latin Rock_ES	4/4	2	120			Finger Bass
Bass	World	2967	MB_Latin Rock_ES	4/4	2	120			:
Bass	World	2968	MC_Latin Rock_ES	4/4	2	120			:
Bass	World	2969	MD_Latin Rock_ES	4/4	4	120			:
Bass	World	2970	IA_Latin Rock_ES	4/4	2	120			:
Bass	World	2971	FA_Latin Rock_ES	4/4	1	120			:
Bass	World	2972	FB_Latin Rock_ES	4/4	1	120			:
Bass	World	2973	MA_Disco Latin_XS	4/4	4	100			:
Bass	World	2974	MB_Disco Latin_XS	4/4	4	100			:
Bass	World	2975	MC_Disco Latin_XS	4/4	4	100			:
Bass	World	2976	FA_Disco Latin_XS	4/4	1	100			:
Bass	World	2977	FB_Disco Latin_XS	4/4	1	100			:
Bass	World	2978	FC_Disco Latin_XS	4/4	1	100			:
Bass	World	2979	BA_Disco Latin_XS	4/4	1	100			:
Bass	World	2980	MA_Latin House_ES	4/4	4	138			:
Bass	World	2981	MC_Latin House_ES	4/4	4	138			:
Bass	World	2982	FA_Latin House_ES	4/4	4	138			Synth Bass

Arpeggio Type List

Main Category	Sub Category	ARP No.	ARP Name	Time Signature	Length	Original Tempo	Accent	Random SFX	Voice Type
Bass	World	2983	MA_Spanish Pop_ES	4/4	1	120			Finger Bass
Bass	World	2984	MB_Spanish Pop_ES	4/4	2	120			:
Bass	World	2985	MC_Spanish Pop_ES	4/4	1	120			:
Bass	World	2986	MD_Spanish Pop_ES	4/4	1	120			:
Bass	World	2987	FA_Spanish Pop_ES	4/4	1	120			:
Bass	World	2988	FC_Spanish Pop_ES	4/4	2	120			:
Bass	World	2989	MA_Turkish Pop_XS	4/4	4	101			Synth Bass
Bass	World	2990	MB_Turkish Pop_XS	4/4	4	101			:
Bass	World	2991	MC_Turkish Pop_XS	4/4	4	101			:
Bass	World	2992	MD_Turkish Pop_XS	4/4	4	101			:
Bass	World	2993	MA_Turkish Pop_ES	4/4	4	101			:
Bass	World	2994	MB_Turkish Pop_ES	4/4	4	101			:
Bass	World	2995	MC_Turkish Pop_ES	4/4	4	101			:
Bass	World	2996	MD_Turkish Pop_ES	4/4	4	101			:
Bass	World	2997	MA_TurkishDance_XS	4/4	4	130			:
Bass	World	2998	MB_TurkishDance_XS	4/4	4	130			:
Bass	World	2999	MC_TurkishDance_XS	4/4	4	130			:
Bass	World	3000	MD_TurkishDance_XS	4/4	4	130			:
Bass	World	3001	MA_TurkishDance_ES	4/4	4	130			:
Bass	World	3002	MB_TurkishDance_ES	4/4	4	130			:
Bass	World	3003	MC_TurkishDance_ES	4/4	4	130			:
Bass	World	3004	MD_TurkishDance_ES	4/4	4	130			:
Bass	World	3005	MA_Turkish_ES	4/4	2	105			Finger Bass
Bass	World	3006	MB_Turkish_ES	4/4	2	105			:
Bass	World	3007	MC_Turkish_ES	9/8	2	125			:
Bass	World	3008	MD_Turkish_ES	9/8	2	125			:
Bass	World	3009	ME_Turkish_ES	4/4	2	105			:
Bass	World	3010	MF_Turkish_ES	4/4	2	105			:
Bass	World	3011	IA_Turkish_ES	4/4	2	86			:
BaMG	Rock	3012	MA_StandardRock_XS	4/4	4	131		○	"Mega Finger+Slap"
BaMG	Rock	3013	MB_StandardRock_XS	4/4	4	131		○	:
BaMG	Rock	3014	MC_StandardRock_XS	4/4	4	131		○	:
BaMG	Rock	3015	FA_StandardRock_XS	4/4	1	131		○	:
BaMG	Rock	3016	FB_StandardRock_XS	4/4	1	131		○	:
BaMG	Rock	3017	FC_StandardRock_XS	4/4	1	131		○	:
BaMG	Rock	3018	BA_StandardRock_XS	4/4	1	131		○	:
BaMG	Rock	3019	MA_Power Rock_XS	4/4	4	120		○	"Mega Pick Open Mute"
BaMG	Rock	3020	MB_Power Rock_XS	4/4	4	120		○	:
BaMG	Rock	3021	MC_Power Rock_XS	4/4	4	120		○	:
BaMG	Rock	3022	FA_Power Rock_XS	4/4	1	120		○	:
BaMG	Rock	3023	FB_Power Rock_XS	4/4	1	120		○	:
BaMG	Rock	3024	FC_Power Rock_XS	4/4	1	120		○	:
BaMG	Rock	3025	BA_Power Rock_XS	4/4	1	120		○	:
BaMG	Rock	3026	MA_ContempRock_XS	4/4	4	126		○	:
BaMG	Rock	3027	MB_ContempRock_XS	4/4	4	126		○	:
BaMG	Rock	3028	MC_ContempRock_XS	4/4	4	126		○	:
BaMG	Rock	3029	FA_ContempRock_XS	4/4	1	126		○	:
BaMG	Rock	3030	FB_ContempRock_XS	4/4	1	126		○	:
BaMG	Rock	3031	FC_ContempRock_XS	4/4	1	126		○	:
BaMG	Rock	3032	BA_ContempRock_XS	4/4	1	126		○	:
BaMG	Rock	3033	MA_Hard Rock_XS	4/4	4	120		○	"Mega Finger+Slap"
BaMG	Rock	3034	MB_Hard Rock_XS	4/4	4	120		○	:
BaMG	Rock	3035	MC_Hard Rock_XS	4/4	4	120		○	:
BaMG	Rock	3036	FA_Hard Rock_XS	4/4	1	120		○	:
BaMG	Rock	3037	FB_Hard Rock_XS	4/4	1	120		○	:
BaMG	Rock	3038	FC_Hard Rock_XS	4/4	1	120		○	:
BaMG	Rock	3039	BA_Hard Rock_XS	4/4	1	120		○	:
BaMG	Rock	3040	MA_Blues Rock_XS	4/4	4	120		○	:
BaMG	Rock	3041	MB_Blues Rock_XS	4/4	4	120		○	:
BaMG	Rock	3042	MC_Blues Rock_XS	4/4	4	120		○	:
BaMG	Rock	3043	FA_Blues Rock_XS	4/4	1	120		○	:
BaMG	Rock	3044	FB_Blues Rock_XS	4/4	1	120		○	:
BaMG	Rock	3045	FC_Blues Rock_XS	4/4	1	120		○	:
BaMG	Rock	3046	BA_Blues Rock_XS	4/4	1	120		○	:
BaMG	Rock	3047	MA_Rock & Roll_XS	4/4	4	172		○	"Mega Pick Open Mute"
BaMG	Rock	3048	MB_Rock & Roll_XS	4/4	4	172		○	:
BaMG	Rock	3049	MC_Rock & Roll_XS	4/4	4	172		○	:
BaMG	Rock	3050	FA_Rock & Roll_XS	4/4	1	172		○	:
BaMG	Rock	3051	FB_Rock & Roll_XS	4/4	1	172		○	:
BaMG	Rock	3052	FC_Rock & Roll_XS	4/4	1	172		○	:
BaMG	Rock	3053	BA_Rock & Roll_XS	4/4	1	172		○	:
BaMG	Rock	3054	MA_Guitar Pop 1_XS	4/4	4	100		○	"Mega Finger+Slap"
BaMG	Rock	3055	MB_Guitar Pop 1_XS	4/4	4	100		○	:
BaMG	Rock	3056	MC_Guitar Pop 1_XS	4/4	4	100		○	:
BaMG	Rock	3057	FA_Guitar Pop 1_XS	4/4	1	100		○	:
BaMG	Rock	3058	FB_Guitar Pop 1_XS	4/4	1	100		○	:
BaMG	Rock	3059	FC_Guitar Pop 1_XS	4/4	1	100		○	:
BaMG	Rock	3060	BA_Guitar Pop 1_XS	4/4	1	100		○	:
BaMG	Rock	3061	MA_Acoustic Pop_XS	4/4	4	110		○	:
BaMG	Rock	3062	MB_Acoustic Pop_XS	4/4	4	110		○	:
BaMG	Rock	3063	MC_Acoustic Pop_XS	4/4	4	110		○	:
BaMG	Rock	3064	FA_Acoustic Pop_XS	4/4	1	110		○	:
BaMG	Rock	3065	FB_Acoustic Pop_XS	4/4	1	110		○	:

Main Category	Sub Category	ARP No.	ARP Name	Time Signature	Length	Original Tempo	Accent	Random SFX	Voice Type
BaMG	Rock	3066	FC_Acoustic Pop_XS	4/4	1	110		○	"Mega Finger+Slap"
BaMG	Rock	3067	MA_GuitarBallad_XS	4/4	8	94		○	:
BaMG	Rock	3068	MB_GuitarBallad_XS	4/4	8	94		○	:
BaMG	Rock	3069	MC_GuitarBallad_XS	4/4	8	94		○	:
BaMG	Rock	3070	FA_GuitarBallad_XS	4/4	1	94		○	:
BaMG	Rock	3071	FB_GuitarBallad_XS	4/4	1	94		○	:
BaMG	Rock	3072	FC_GuitarBallad_XS	4/4	1	94		○	:
BaMG	Rock	3073	BA_GuitarBallad_XS	4/4	1	94		○	:
BaMG	Rock	3074	MA_Unplugged 1_XS	4/4	4	120		○	"Mega Acoustic Bass"
BaMG	Rock	3075	MB_Unplugged 1_XS	4/4	4	120		○	:
BaMG	Rock	3076	MC_Unplugged 1_XS	4/4	4	120		○	:
BaMG	Rock	3077	FA_Unplugged 1_XS	4/4	1	120		○	:
BaMG	Rock	3078	FB_Unplugged 1_XS	4/4	1	120		○	:
BaMG	Rock	3079	FC_Unplugged 1_XS	4/4	1	120		○	:
BaMG	Rock	3080	BA_Unplugged 1_XS	4/4	1	120		○	:
BaMG	Rock	3081	MA_Unplugged 2_XS	4/4	8	120		○	"Mega Finger+Slap"
BaMG	Rock	3082	MB_Unplugged 2_XS	4/4	8	120		○	:
BaMG	Rock	3083	MC_Unplugged 2_XS	4/4	8	120		○	:
BaMG	Rock	3084	FA_Unplugged 2_XS	4/4	1	120		○	:
BaMG	Rock	3085	FB_Unplugged 2_XS	4/4	1	120		○	:
BaMG	Rock	3086	FC_Unplugged 2_XS	4/4	1	120		○	:
BaMG	Rock	3087	BA_Unplugged 2_XS	4/4	1	120		○	:
BaMG	Rock	3088	MA_Worship Slow_XS	4/4	4	75		○	:
BaMG	Rock	3089	MB_Worship Slow_XS	4/4	4	75		○	:
BaMG	Rock	3090	MC_Worship Slow_XS	4/4	4	75		○	:
BaMG	Rock	3091	FA_Worship Slow_XS	4/4	1	75		○	:
BaMG	Rock	3092	FB_Worship Slow_XS	4/4	1	75		○	:
BaMG	Rock	3093	FC_Worship Slow_XS	4/4	1	75		○	:
BaMG	Rock	3094	BA_Worship Slow_XS	4/4	1	75		○	:
BaMG	Rock	3095	MA_Worship Med_XS	4/4	8	140		○	"Mega Acoustic Bass"
BaMG	Rock	3096	MB_Worship Med_XS	4/4	4	140		○	:
BaMG	Rock	3097	MC_Worship Med_XS	4/4	4	140		○	:
BaMG	Rock	3098	FA_Worship Med_XS	4/4	1	140		○	:
BaMG	Rock	3099	FB_Worship Med_XS	4/4	1	140		○	:
BaMG	Rock	3100	FC_Worship Med_XS	4/4	1	140		○	:
BaMG	Rock	3101	BA_Worship Med_XS	4/4	1	140		○	:
BaMG	Rock	3102	MA_Worship Fast_XS	4/4	8	114		○	"Mega Finger+Slap"
BaMG	Rock	3103	MB_Worship Fast_XS	4/4	4	114		○	:
BaMG	Rock	3104	MC_Worship Fast_XS	4/4	4	114		○	:
BaMG	Rock	3105	FA_Worship Fast_XS	4/4	1	114		○	:
BaMG	Rock	3106	FB_Worship Fast_XS	4/4	1	114		○	:
BaMG	Rock	3107	FC_Worship Fast_XS	4/4	1	114		○	:
BaMG	Rock	3108	BA_Worship Fast_XS	4/4	1	114		○	:
BaMG	Rock	3109	MA_New Country_XS	4/4	2	118		○	:
BaMG	Rock	3110	MB_New Country_XS	4/4	4	118		○	:
BaMG	Rock	3111	MC_New Country_XS	4/4	2	118		○	:
BaMG	Rock	3112	FA_New Country_XS	4/4	1	118		○	:
BaMG	Rock	3113	FB_New Country_XS	4/4	1	118		○	:
BaMG	Rock	3114	FC_New Country_XS	4/4	1	118		○	:
BaMG	Rock	3115	BA_New Country_XS	4/4	1	118		○	:
BaMG	Rock	3116	MA_VintageGPop_XS	4/4	4	148		○	:
BaMG	Rock	3117	MB_VintageGPop_XS	4/4	4	148		○	:
BaMG	Rock	3118	MC_VintageGPop_XS	4/4	4	148		○	:
BaMG	Rock	3119	FA_VintageGPop_XS	4/4	1	148		○	:
BaMG	Rock	3120	FB_VintageGPop_XS	4/4	1	148		○	:
BaMG	Rock	3121	FC_VintageGPop_XS	4/4	1	148		○	:
BaMG	Rock	3122	BA_VintageGPop_XS	4/4	1	148		○	:
BaMG	Rock	3123	MA_WestCoastPop_XS	4/4	4	100		○	:
BaMG	Rock	3124	MB_WestCoastPop_XS	4/4	4	100		○	:
BaMG	Rock	3125	MC_WestCoastPop_XS	4/4	4	100		○	:
BaMG	Rock	3126	FA_WestCoastPop_XS	4/4	1	100		○	:
BaMG	Rock	3127	FB_WestCoastPop_XS	4/4	1	100		○	:
BaMG	Rock	3128	FC_WestCoastPop_XS	4/4	1	100		○	:
BaMG	Rock	3129	BA_WestCoastPop_XS	4/4	1	100		○	:
BaMG	Rock	3130	MA_Brit Pop_XS	4/4	2	86		○	:
BaMG	Rock	3131	MB_Brit Pop_XS	4/4	2	86		○	:
BaMG	Rock	3132	MC_Brit Pop_XS	4/4	2	86		○	:
BaMG	Rock	3133	FA_Brit Pop_XS	4/4	1	86		○	:
BaMG	Rock	3134	FB_Brit Pop_XS	4/4	1	86		○	:
BaMG	Rock	3135	FC_Brit Pop_XS	4/4	1	86		○	:
BaMG	Rock	3136	BA_Brit Pop_XS	4/4	1	86		○	:
BaMG	Rock	3137	MA_BritPopSwing_XS	4/4	2	110		○	:
BaMG	Rock	3138	MB_BritPopSwing_XS	4/4	2	110		○	:
BaMG	Rock	3139	MC_BritPopSwing_XS	4/4	2	110		○	:
BaMG	Rock	3140	FA_BritPopSwing_XS	4/4	1	110		○	:
BaMG	Rock	3141	FB_BritPopSwing_XS	4/4	1	110		○	:
BaMG	Rock	3142	FC_BritPopSwing_XS	4/4	1	110		○	:
BaMG	Rock	3143	BA_BritPopSwing_XS	4/4	1	110		○	:
BaMG	Rock	3144	MA_8Beat Ballad_XS	4/4					

Arpeggio Type List

Main Category	Sub Category	ARP No.	ARP Name	Time Signature	Length	Original Tempo	Accent	Random SFX	Voice Type
BaMG	Rock	3149	FC_8BeatBallad_XS	4/4	1	101		○	*Mega Finger+Slap
BaMG	Rock	3150	BA_8BeatBallad_XS	4/4	1	101		○	:
BaMG	Rock	3151	MA_EPBallad_XS	4/4	2	60		○	:
BaMG	Rock	3152	MB_EPBallad_XS	4/4	2	60		○	:
BaMG	Rock	3153	MC_EPBallad_XS	4/4	2	60		○	:
BaMG	Rock	3154	FA_EPBallad_XS	4/4	1	60		○	:
BaMG	Rock	3155	FB_EPBallad_XS	4/4	1	60		○	:
BaMG	Rock	3156	FC_EPBallad_XS	4/4	1	60		○	:
BaMG	Rock	3157	BA_EPBallad_XS	4/4	1	60		○	:
BaMG	Rock	3158	MA_Cool8Beat_XS	4/4	2	100		○	:
BaMG	Rock	3159	MB_Cool8Beat_XS	4/4	2	100		○	:
BaMG	Rock	3160	MC_Cool8Beat_XS	4/4	2	100		○	:
BaMG	Rock	3161	FA_Cool8Beat_XS	4/4	1	100		○	:
BaMG	Rock	3162	FB_Cool8Beat_XS	4/4	1	100		○	:
BaMG	Rock	3163	FC_Cool8Beat_XS	4/4	1	100		○	:
BaMG	Rock	3164	BA_Cool8Beat_XS	4/4	1	100		○	:
BaMG	Rock	3165	MA_16BeatPop1_XS	4/4	4	103		○	*Mega Slap Bass
BaMG	Rock	3166	MB_16BeatPop1_XS	4/4	4	103		○	:
BaMG	Rock	3167	MC_16BeatPop1_XS	4/4	4	103		○	:
BaMG	Rock	3168	FA_16BeatPop1_XS	4/4	1	103		○	:
BaMG	Rock	3169	FB_16BeatPop1_XS	4/4	1	103		○	:
BaMG	Rock	3170	FC_16BeatPop1_XS	4/4	1	103		○	:
BaMG	Rock	3171	BA_16BeatPop1_XS	4/4	1	103		○	:
BaMG	Rock	3172	MA_16BeatPop1_ES	4/4	4	103		○	:
BaMG	Rock	3173	MB_16BeatPop1_ES	4/4	4	103		○	:
BaMG	Rock	3174	MC_16BeatPop1_ES	4/4	4	103		○	:
BaMG	Rock	3175	FA_16BeatPop1_ES	4/4	1	103		○	:
BaMG	Rock	3176	FB_16BeatPop1_ES	4/4	1	103		○	:
BaMG	Rock	3177	FC_16BeatPop1_ES	4/4	1	103		○	:
BaMG	Rock	3178	BA_16BeatPop1_ES	4/4	1	103		○	:
BaMG	R&B	3179	MA_Funk1_XS	4/4	8	104		○	*Mega Finger+Slap
BaMG	R&B	3180	MB_Funk1_XS	4/4	8	104		○	:
BaMG	R&B	3181	MC_Funk1_XS	4/4	8	104		○	:
BaMG	R&B	3182	FA_Funk1_XS	4/4	1	104		○	:
BaMG	R&B	3183	FB_Funk1_XS	4/4	1	104		○	:
BaMG	R&B	3184	FC_Funk1_XS	4/4	1	104		○	:
BaMG	R&B	3185	BA_Funk1_XS	4/4	1	104		○	:
BaMG	R&B	3186	MA_FunkPopRock_XS	4/4	4	95		○	:
BaMG	R&B	3187	MB_FunkPopRock_XS	4/4	4	95		○	:
BaMG	R&B	3188	MC_FunkPopRock_XS	4/4	4	95		○	:
BaMG	R&B	3189	FA_FunkPopRock_XS	4/4	1	95		○	:
BaMG	R&B	3190	FB_FunkPopRock_XS	4/4	1	95		○	:
BaMG	R&B	3191	FC_FunkPopRock_XS	4/4	1	95		○	:
BaMG	R&B	3192	BA_FunkPopRock_XS	4/4	1	95		○	:
BaMG	R&B	3193	MA_JazzFunk1_XS	4/4	4	120		○	:
BaMG	R&B	3194	MB_JazzFunk1_XS	4/4	4	120		○	:
BaMG	R&B	3195	MC_JazzFunk1_XS	4/4	4	120		○	:
BaMG	R&B	3196	FA_JazzFunk1_XS	4/4	1	120		○	:
BaMG	R&B	3197	FB_JazzFunk1_XS	4/4	1	120		○	:
BaMG	R&B	3198	FC_JazzFunk1_XS	4/4	1	120		○	:
BaMG	R&B	3199	BA_JazzFunk1_XS	4/4	1	120		○	:
BaMG	R&B	3200	MA_JazzPop_XS	4/4	2	102		○	:
BaMG	R&B	3201	MB_JazzPop_XS	4/4	2	102		○	:
BaMG	R&B	3202	MC_JazzPop_XS	4/4	2	102		○	:
BaMG	R&B	3203	FA_JazzPop_XS	4/4	1	102		○	:
BaMG	R&B	3204	FB_JazzPop_XS	4/4	1	102		○	:
BaMG	R&B	3205	FC_JazzPop_XS	4/4	1	102		○	:
BaMG	R&B	3206	BA_JazzPop_XS	4/4	1	102		○	:
BaMG	R&B	3207	MA_Slow&Easy_XS	4/4	4	72		○	:
BaMG	R&B	3208	MB_Slow&Easy_XS	4/4	4	72		○	:
BaMG	R&B	3209	MC_Slow&Easy_XS	4/4	4	72		○	:
BaMG	R&B	3210	FA_Slow&Easy_XS	4/4	1	72		○	:
BaMG	R&B	3211	FB_Slow&Easy_XS	4/4	1	72		○	:
BaMG	R&B	3212	FC_Slow&Easy_XS	4/4	1	72		○	:
BaMG	R&B	3213	BA_Slow&Easy_XS	4/4	1	72		○	:
BaMG	R&B	3214	MA_GospelFunk_XS	4/4	4	106		○	:
BaMG	R&B	3215	MB_GospelFunk_XS	4/4	4	106		○	:
BaMG	R&B	3216	MC_GospelFunk_XS	4/4	4	106		○	:
BaMG	R&B	3217	FA_GospelFunk_XS	4/4	1	106		○	:
BaMG	R&B	3218	FB_GospelFunk_XS	4/4	1	106		○	:
BaMG	R&B	3219	FC_GospelFunk_XS	4/4	1	106		○	:
BaMG	R&B	3220	BA_GospelFunk_XS	4/4	1	106		○	:
BaMG	R&B	3221	MA_FunkDisco_XS	4/4	2	126		○	:
BaMG	R&B	3222	MB_FunkDisco_XS	4/4	2	126		○	:
BaMG	R&B	3223	MC_FunkDisco_XS	4/4	2	126		○	:
BaMG	R&B	3224	FA_FunkDisco_XS	4/4	1	126		○	:
BaMG	R&B	3225	FB_FunkDisco_XS	4/4	1	126		○	:
BaMG	R&B	3226	FC_FunkDisco_XS	4/4	1	126		○	:
BaMG	R&B	3227	BA_FunkDisco_XS	4/4	1	126		○	:
BaMG	R&B	3228	MA_StandrdDisco_XS	4/4	4	120		○	:
BaMG	R&B	3229	MB_StandrdDisco_XS	4/4	4	120		○	:
BaMG	R&B	3230	MC_StandrdDisco_XS	4/4	4	120		○	:
BaMG	R&B	3231	FA_StandrdDisco_XS	4/4	1	120		○	:

Main Category	Sub Category	ARP No.	ARP Name	Time Signature	Length	Original Tempo	Accent	Random SFX	Voice Type
BaMG	R&B	3232	FB_StandrdDisco_XS	4/4	1	120		○	*Mega Finger+Slap
BaMG	R&B	3233	FC_StandrdDisco_XS	4/4	1	120		○	:
BaMG	R&B	3234	BA_StandrdDisco_XS	4/4	1	120		○	:
BaMG	R&B	3235	MA_RetroDisco_XS	4/4	4	108		○	:
BaMG	R&B	3236	MB_RetroDisco_XS	4/4	4	108		○	:
BaMG	R&B	3237	MC_RetroDisco_XS	4/4	4	108		○	:
BaMG	R&B	3238	FA_RetroDisco_XS	4/4	1	108		○	:
BaMG	R&B	3239	FB_RetroDisco_XS	4/4	1	108		○	:
BaMG	R&B	3240	FC_RetroDisco_XS	4/4	1	108		○	:
BaMG	R&B	3241	BA_RetroDisco_XS	4/4	1	108		○	:
BaMG	R&B	3242	MA_70sCoolDisco_XS	4/4	4	114		○	:
BaMG	R&B	3243	MB_70sCoolDisco_XS	4/4	4	114		○	:
BaMG	R&B	3244	MC_70sCoolDisco_XS	4/4	4	114		○	:
BaMG	R&B	3245	FA_70sCoolDisco_XS	4/4	1	114		○	:
BaMG	R&B	3246	FB_70sCoolDisco_XS	4/4	1	114		○	:
BaMG	R&B	3247	FC_70sCoolDisco_XS	4/4	1	114		○	:
BaMG	R&B	3248	BA_70sCoolDisco_XS	4/4	1	114		○	:
BaMG	R&B	3249	MA_70sDiscoFunk_XS	4/4	4	112		○	:
BaMG	R&B	3250	MB_70sDiscoFunk_XS	4/4	4	112		○	:
BaMG	R&B	3251	MC_70sDiscoFunk_XS	4/4	4	112		○	:
BaMG	R&B	3252	FA_70sDiscoFunk_XS	4/4	1	112		○	:
BaMG	R&B	3253	FB_70sDiscoFunk_XS	4/4	1	112		○	:
BaMG	R&B	3254	FC_70sDiscoFunk_XS	4/4	1	112		○	:
BaMG	R&B	3255	BA_70sDiscoFunk_XS	4/4	1	112		○	:
BaMG	R&B	3256	MA_Philadelphia_XS	4/4	2	100		○	:
BaMG	R&B	3257	MB_Philadelphia_XS	4/4	2	100		○	:
BaMG	R&B	3258	MC_Philadelphia_XS	4/4	2	100		○	:
BaMG	R&B	3259	FA_Philadelphia_XS	4/4	1	100		○	:
BaMG	R&B	3260	FB_Philadelphia_XS	4/4	1	100		○	:
BaMG	R&B	3261	FC_Philadelphia_XS	4/4	1	100		○	:
BaMG	R&B	3262	BA_Philadelphia_XS	4/4	1	100		○	:
BaMG	R&B	3263	MA_Soul1_XS	4/4	2	116		○	:
BaMG	R&B	3264	MB_Soul1_XS	4/4	2	116		○	:
BaMG	R&B	3265	MC_Soul1_XS	4/4	2	116		○	:
BaMG	R&B	3266	FA_Soul1_XS	4/4	1	116		○	:
BaMG	R&B	3267	FB_Soul1_XS	4/4	1	116		○	:
BaMG	R&B	3268	FC_Soul1_XS	4/4	1	116		○	:
BaMG	R&B	3269	BA_Soul1_XS	4/4	1	116		○	:
BaMG	R&B	3270	MA_70sChartSoul_XS	4/4	2	108		○	:
BaMG	R&B	3271	MB_70sChartSoul_XS	4/4	2	108		○	:
BaMG	R&B	3272	MC_70sChartSoul_XS	4/4	2	108		○	:
BaMG	R&B	3273	FA_70sChartSoul_XS	4/4	1	108		○	:
BaMG	R&B	3274	FB_70sChartSoul_XS	4/4	1	108		○	:
BaMG	R&B	3275	FC_70sChartSoul_XS	4/4	1	108		○	:
BaMG	R&B	3276	BA_70sChartSoul_XS	4/4	1	108		○	:
BaMG	R&B	3277	MA_FranklySoul_XS	4/4	4	120		○	:
BaMG	R&B	3278	MB_FranklySoul_XS	4/4	4	120		○	:
BaMG	R&B	3279	MC_FranklySoul_XS	4/4	4	120		○	:
BaMG	R&B	3280	FA_FranklySoul_XS	4/4	1	120		○	:
BaMG	R&B	3281	FB_FranklySoul_XS	4/4	1	120		○	:
BaMG	R&B	3282	FC_FranklySoul_XS	4/4	1	120		○	:
BaMG	R&B	3283	BA_FranklySoul_XS	4/4	1	120		○	:
BaMG	R&B	3284	MA_SoulBand_XS	4/4	4	129		○	:
BaMG	R&B	3285	MB_SoulBand_XS	4/4	4	129		○	:
BaMG	R&B	3286	MC_SoulBand_XS	4/4	4	129		○	:
BaMG	R&B	3287	FA_SoulBand_XS	4/4	1	129		○	:
BaMG	R&B	3288	FB_SoulBand_XS	4/4	1	129		○	:
BaMG	R&B	3289	FC_SoulBand_XS	4/4	1	129		○	:
BaMG	R&B	3290	BA_SoulBand_XS	4/4	1	129		○	:
BaMG	R&B	3291	MA_SoulShuffle_XS	4/4	4	98		○	:
BaMG	R&B	3292	MB_SoulShuffle_XS	4/4	4	98		○	:
BaMG	R&B	3293	MC_SoulShuffle_XS	4/4	4	98		○	:
BaMG	R&B	3294	FA_SoulShuffle_XS	4/4	1	98		○	:
BaMG	R&B	3295	FB_SoulShuffle_XS	4/4	1	98		○	:
BaMG	R&B	3296	FC_SoulShuffle_XS	4/4	1	98		○	:
BaMG	R&B	3297	BA_SoulShuffle_XS	4/4	1	98		○	:
BaMG	R&B	3298	MA_SoulSwing_XS	4/4	4	124		○	:
BaMG	R&B	3299	MB_SoulSwing_XS	4/4	4	124		○	:
BaMG	R&B	3300	MC_SoulSwing_XS	4/4	4	124		○	:
BaMG	R&B	3301	FA_SoulSwing_XS	4/4	1	124		○	:
BaMG	R&B	3302	FB_SoulSwing_XS	4/4	1	124		○	:
BaMG	R&B	3303	FC_SoulSwing_XS	4/4	1	124		○	:
BaMG	R&B	3304	BA_SoulSwing_XS	4/4	1	124		○	:
BaMG	R&B	3305	MA_GospelBrothr_XS	4/4	4	108			

Arpeggio Type List

Main Category	Sub Category	ARP No.	ARP Name	Time Signature	Length	Original Tempo	Accent	Random SFX	Voice Type
BaMG	Jazz	3315	FA_Modern Jazz_XS	4/4	1	218		○	"Mega Acoustic Bass"
BaMG	Jazz	3316	FB_Modern Jazz_XS	4/4	1	218		○	:
BaMG	Jazz	3317	FC_Modern Jazz_XS	4/4	1	218		○	:
BaMG	Jazz	3318	BA_Modern Jazz_XS	4/4	1	218		○	:
BaMG	Jazz	3319	MA_R&R Shuffle_XS	4/4	4	192		○	:
BaMG	Jazz	3320	MB_R&R Shuffle_XS	4/4	4	192		○	:
BaMG	Jazz	3321	MC_R&R Shuffle_XS	4/4	4	192		○	:
BaMG	Jazz	3322	FA_R&R Shuffle_XS	4/4	1	192		○	:
BaMG	Jazz	3323	FB_R&R Shuffle_XS	4/4	1	192		○	:
BaMG	Jazz	3324	FC_R&R Shuffle_XS	4/4	1	192		○	:
BaMG	Jazz	3325	BA_R&R Shuffle_XS	4/4	1	192		○	:
BaMG	Jazz	3326	MA_ShuffleBlues_XS	4/4	4	115		○	"Mega Pick Open Mute"
BaMG	Jazz	3327	MB_ShuffleBlues_XS	4/4	4	115		○	:
BaMG	Jazz	3328	MC_ShuffleBlues_XS	4/4	4	115		○	:
BaMG	Jazz	3329	FA_ShuffleBlues_XS	4/4	1	115		○	:
BaMG	Jazz	3330	FB_ShuffleBlues_XS	4/4	1	115		○	:
BaMG	Jazz	3331	FC_ShuffleBlues_XS	4/4	1	115		○	:
BaMG	Jazz	3332	BA_ShuffleBlues_XS	4/4	1	115		○	:
BaMG	Jazz	3333	MA_Slow Blues 1_XS	4/4	2	49		○	"Mega Finger+Slap"
BaMG	Jazz	3334	MB_Slow Blues 1_XS	4/4	2	49		○	:
BaMG	Jazz	3335	MC_Slow Blues 1_XS	4/4	2	49		○	:
BaMG	Jazz	3336	FA_Slow Blues 1_XS	4/4	1	49		○	:
BaMG	Jazz	3337	FB_Slow Blues 1_XS	4/4	1	49		○	:
BaMG	Jazz	3338	FC_Slow Blues 1_XS	4/4	1	49		○	:
BaMG	Jazz	3339	BA_Slow Blues 1_XS	4/4	1	49		○	:
BaMG	Jazz	3340	MA_Piano Boogie_XS	4/4	8	160		○	"Mega Acoustic Bass"
BaMG	Jazz	3341	MB_Piano Boogie_XS	4/4	4	160		○	:
BaMG	Jazz	3342	MC_Piano Boogie_XS	4/4	4	160		○	:
BaMG	Jazz	3343	FA_Piano Boogie_XS	4/4	1	160		○	:
BaMG	Jazz	3344	FB_Piano Boogie_XS	4/4	1	160		○	:
BaMG	Jazz	3345	FC_Piano Boogie_XS	4/4	1	160		○	:
BaMG	Jazz	3346	BA_Piano Boogie_XS	4/4	1	160		○	:
BaMG	World	3347	MA_ReggaeShuffle_XS	4/4	4	90		○	"Mega Finger+Slap"
BaMG	World	3348	MB_ReggaeShuffle_XS	4/4	4	90		○	:
BaMG	World	3349	MC_ReggaeShuffle_XS	4/4	4	90		○	:
BaMG	World	3350	FA_ReggaeShuffle_XS	4/4	1	90		○	:
BaMG	World	3351	FB_ReggaeShuffle_XS	4/4	1	90		○	:
BaMG	World	3352	FC_ReggaeShuffle_XS	4/4	1	90		○	:
BaMG	World	3353	BA_ReggaeShuffle_XS	4/4	1	90		○	:
BaMG	World	3354	MA_Salsa 1_XS	4/4	4	177		○	"Mega Acoustic Bass"
BaMG	World	3355	MB_Salsa 1_XS	4/4	4	177		○	:
BaMG	World	3356	MC_Salsa 1_XS	4/4	4	177		○	:
BaMG	World	3357	FA_Salsa 1_XS	4/4	1	177		○	:
BaMG	World	3358	FB_Salsa 1_XS	4/4	1	177		○	:
BaMG	World	3359	FC_Salsa 1_XS	4/4	1	177		○	:
BaMG	World	3360	BA_Salsa 1_XS	4/4	1	177		○	:
BaMG	World	3361	MA_AfroCuban_XS	4/4	4	200		○	:
BaMG	World	3362	MB_AfroCuban_XS	4/4	4	200		○	:
BaMG	World	3363	MC_AfroCuban_XS	4/4	4	200		○	:
BaMG	World	3364	FA_AfroCuban_XS	4/4	1	200		○	:
BaMG	World	3365	FB_AfroCuban_XS	4/4	1	200		○	:
BaMG	World	3366	FC_AfroCuban_XS	4/4	1	200		○	:
BaMG	World	3367	BA_AfroCuban_XS	4/4	1	200		○	:
BaMG	World	3368	MA_Brazil Samba_XS	4/4	4	96		○	"Mega Finger+Slap"
BaMG	World	3369	MB_Brazil Samba_XS	4/4	4	96		○	:
BaMG	World	3370	MC_Brazil Samba_XS	4/4	4	96		○	:
BaMG	World	3371	FA_Brazil Samba_XS	4/4	1	96		○	:
BaMG	World	3372	FB_Brazil Samba_XS	4/4	1	96		○	:
BaMG	World	3373	FC_Brazil Samba_XS	4/4	1	96		○	:
BaMG	World	3374	BA_Brazil Samba_XS	4/4	1	96		○	:
BaMG	World	3375	MA_Bomba_XS	4/4	4	99		○	"Mega Acoustic Bass"
BaMG	World	3376	MB_Bomba_XS	4/4	4	99		○	:
BaMG	World	3377	MC_Bomba_XS	4/4	4	99		○	:
BaMG	World	3378	FA_Bomba_XS	4/4	1	99		○	:
BaMG	World	3379	FB_Bomba_XS	4/4	1	99		○	:
BaMG	World	3380	FC_Bomba_XS	4/4	1	99		○	:
BaMG	World	3381	BA_Bomba_XS	4/4	1	99		○	:
BaMG	World	3382	MA_Bossa_XS	4/4	4	124		○	"Mega Finger+Slap"
BaMG	World	3383	MB_Bossa_XS	4/4	4	124		○	:
BaMG	World	3384	MC_Bossa_XS	4/4	4	124		○	:
BaMG	World	3385	FA_Bossa_XS	4/4	1	124		○	:
BaMG	World	3386	FB_Bossa_XS	4/4	1	124		○	:
BaMG	World	3387	FC_Bossa_XS	4/4	1	124		○	:
BaMG	World	3388	BA_Bossa_XS	4/4	1	124		○	:
BaMG	World	3389	MA_Merengue_XS	4/4	4	130		○	:
BaMG	World	3390	MB_Merengue_XS	4/4	4	130		○	:
BaMG	World	3391	MC_Merengue_XS	4/4	4	130		○	:
BaMG	World	3392	FA_Merengue_XS	4/4	1	130		○	:
BaMG	World	3393	FB_Merengue_XS	4/4	1	130		○	:
BaMG	World	3394	FC_Merengue_XS	4/4	1	130		○	:
BaMG	World	3395	BA_Merengue_XS	4/4	1	130		○	:
BaMG	World	3396	MA_RumbaFlamenc_XS	4/4	4	106		○	:
BaMG	World	3397	MB_RumbaFlamenc_XS	4/4	4	106		○	:

Main Category	Sub Category	ARP No.	ARP Name	Time Signature	Length	Original Tempo	Accent	Random SFX	Voice Type
BaMG	World	3398	MC_RumbaFlamenc_XS	4/4	4	106		○	"Mega Finger+Slap"
BaMG	World	3399	FA_RumbaFlamenc_XS	4/4	1	106		○	:
BaMG	World	3400	FB_RumbaFlamenc_XS	4/4	1	106		○	:
BaMG	World	3401	FC_RumbaFlamenc_XS	4/4	1	106		○	:
BaMG	World	3402	BA_RumbaFlamenc_XS	4/4	1	106		○	:
BaMG	World	3403	MA_Guaguanco_XS	4/4	4	120		○	"Mega Acoustic Bass"
BaMG	World	3404	MB_Guaguanco_XS	4/4	4	120		○	:
BaMG	World	3405	MC_Guaguanco_XS	4/4	4	120		○	:
BaMG	World	3406	FA_Guaguanco_XS	4/4	1	120		○	:
BaMG	World	3407	FB_Guaguanco_XS	4/4	1	120		○	:
BaMG	World	3408	FC_Guaguanco_XS	4/4	1	120		○	:
BaMG	World	3409	BA_Guaguanco_XS	4/4	1	120		○	:
BaMG	World	3410	MA_Irish Hymn_XS	3/4	4	70		○	"Mega Finger+Slap"
BaMG	World	3411	MB_Irish Hymn_XS	3/4	4	70		○	:
BaMG	World	3412	MC_Irish Hymn_XS	3/4	4	70		○	:
BaMG	World	3413	FA_Irish Hymn_XS	3/4	1	70		○	:
BaMG	World	3414	FB_Irish Hymn_XS	3/4	1	70		○	:
BaMG	World	3415	FC_Irish Hymn_XS	3/4	1	70		○	:
BaMG	World	3416	BA_Irish Hymn_XS	3/4	1	70		○	:
Strng	Rock	3417	MA_8Beat Ballad_XS	4/4	4	101			Strings
Strng	Rock	3418	MB_8Beat Ballad_XS	4/4	4	101			:
Strng	Rock	3419	MC_8Beat Ballad_XS	4/4	4	101			:
Strng	Rock	3420	FA_8Beat Ballad_XS	4/4	1	101			:
Strng	Rock	3421	FB_8Beat Ballad_XS	4/4	1	101			:
Strng	Rock	3422	FC_8Beat Ballad_XS	4/4	1	101			:
Strng	Rock	3423	BA_8Beat Ballad_XS	4/4	1	101			:
Strng	R&B	3424	MC_New R&B 2	4/4	1	97			Harp
Strng	R&B	3425	MD_New R&B 2	4/4	1	97			:
Strng	R&B	3426	MA_New R&B 3_ES	4/4	2	90			Strings
Strng	R&B	3427	MB_New R&B 3_ES	4/4	2	90			:
Strng	R&B	3428	MC_New R&B 3_ES	4/4	2	90			:
Strng	R&B	3429	MD_New R&B 3/1_ES	4/4	2	90			:
Strng	R&B	3430	MA_New R&B 3/2_ES	4/4	2	90			:
Strng	R&B	3431	FB_New R&B 3_ES	4/4	1	90			:
Strng	R&B	3432	FC_New R&B 3_ES	4/4	2	90			:
Strng	R&B	3433	BA_Pop R&B_XS	4/4	4	67			:
Strng	R&B	3434	MA_Pop R&B_XS	4/4	4	67			:
Strng	R&B	3435	MC_Pop R&B_XS	4/4	4	67			:
Strng	R&B	3436	FA_Pop R&B_XS	4/4	1	67			:
Strng	R&B	3437	FB_Pop R&B_XS	4/4	1	67			:
Strng	R&B	3438	FC_Pop R&B_XS	4/4	1	67			:
Strng	R&B	3439	MA1_R&B Ana Pop_XS	4/4	4	95			Harp
Strng	R&B	3440	MB1_R&B Ana Pop_XS	4/4	4	95			:
Strng	R&B	3441	MC1_R&B Ana Pop_XS	4/4	4	95			:
Strng	R&B	3442	FA1_R&B Ana Pop_XS	4/4	1	95			:
Strng	R&B	3443	FB1_R&B Ana Pop_XS	4/4	1	95			:
Strng	R&B	3444	FC1_R&B Ana Pop_XS	4/4	1	95			:
Strng	R&B	3445	BA1_R&B Ana Pop_XS	4/4	1	95			:
Strng	R&B	3446	MA2_R&B Ana Pop_XS	4/4	4	95			Strings
Strng	R&B	3447	MB2_R&B Ana Pop_XS	4/4	4	95			:
Strng	R&B	3448	MC2_R&B Ana Pop_XS	4/4	4	95			:
Strng	R&B	3449	FA2_R&B Ana Pop_XS	4/4	1	95			:
Strng	R&B	3450	FB2_R&B Ana Pop_XS	4/4	1	95			:
Strng	R&B	3451	FC2_R&B Ana Pop_XS	4/4	1	95			:
Strng	R&B	3452	MC_Smooth 1_ES	4/4	2	115			Pizzicato Strings
Strng	R&B	3453	MD_Smooth 1_ES	4/4	2	115			:
Strng	R&B	3454	MA_Flip Hop 1_ES	4/4	2	132			:
Strng	R&B	3455	MB_Flip Hop 1_ES	4/4	2	132			:
Strng	R&B	3456	FC_Flip Hop 1_ES	4/4	1	132			:
Strng	R&B	3457	MA_DirtySynth_ES	4/4	4	85			Strings
Strng	R&B	3458	MB_DirtySynth	4/4	4	85			:
Strng	R&B	3459	MC_DirtySynth	4/4	4	85			:
Strng	R&B	3460	MA_HipHopEpic_XS	4/4	2	85			:
Strng	R&B	3461	MB_HipHopEpic	4/4	2	85			:
Strng	R&B	3462	MC_HipHopEpic	4/4	2	85			:
Strng	R&B	3463	FA_HipHopEpic	4/4	2	85			:
Strng	R&B	3464	FB_Hip Hop 1_ES	4/4	2	105			Pizzicato Strings
Strng	R&B	3465	MC_Hip Hop 1_ES	4/4	2	105			:
Strng	R&B	3466	FA_Hip Hop 1_ES	4/4	1	105			:
Strng	R&B	3467	MD_Hip Hop 3_ES	4/4	2	104			Harp
Strng	Elect	3468	MA_Psyche Pizz1_ES	4/4	1	143			Pizzicato Strings
Strng	Elect	3469	MC_Psyche Pizz2_ES	4/4	1	143			:
Strng	Elect	3470	MA_Psyche Pizz3_ES	4/4	2	143			:
Strng	Elect	3471	MC_Psyche Pizz4_ES	4/4	3	143			:
Strng	Elect	3472	MA_Psyche Pizz5_ES	4/4	2	143			:
Strng	World	3473	MA_Irish Hymn_XS	3/4	4	70			Strings
Strng	World	3474	MB_Irish Hymn_XS	3/4	4	70			

Arpeggio Type List

Main Category	Sub Category	ARP No.	ARP Name	Time Signature	Length	Original Tempo	Accent	Random SFX	Voice Type
Strng	World	3481	MF_Turkish_ES	4/4	2	105			Strings
Strng	World	3482	IA_Turkish_ES	4/4	2	86			:
Strng	Genrl	3483	MA1_Orchestra_XS	4/4	4	102			:
Strng	Genrl	3484	MB1_Orchestra_XS	4/4	8	102			:
Strng	Genrl	3485	MC1_Orchestra_XS	4/4	8	102			:
Strng	Genrl	3486	MD1_Orchestra_XS	4/4	4	102			:
Strng	Genrl	3487	FA1_Orchestra_XS	4/4	1	102			:
Strng	Genrl	3488	MA2_Orchestra_XS	4/4	4	102			Harp
Strng	Genrl	3489	MB2_Orchestra_XS	4/4	8	102			:
Strng	Genrl	3490	MC2_Orchestra_XS	4/4	8	102			:
Strng	Genrl	3491	MD2_Orchestra_XS	4/4	4	102			:
Strng	Genrl	3492	FA2_Orchestra_XS	4/4	1	102			:
Strng	Genrl	3493	MA1_Baroque_XS	4/4	4	88			Strings
Strng	Genrl	3494	MB1_Baroque_XS	4/4	4	88			:
Strng	Genrl	3495	MC1_Baroque_XS	4/4	4	88			:
Strng	Genrl	3496	MD1_Baroque_XS	4/4	4	88			:
Strng	Genrl	3497	FA1_Baroque_XS	4/4	1	88			:
Strng	Genrl	3498	FB1_Baroque_XS	4/4	1	88			:
Strng	Genrl	3499	FC1_Baroque_XS	4/4	1	88			:
Strng	Genrl	3500	FD1_Baroque_XS	4/4	1	88			:
Strng	Genrl	3501	MA2_Baroque_XS	4/4	4	88			:
Strng	Genrl	3502	MB2_Baroque_XS	4/4	4	88			:
Strng	Genrl	3503	MC2_Baroque_XS	4/4	4	88			:
Strng	Genrl	3504	MD2_Baroque_XS	4/4	4	88			:
Strng	Genrl	3505	FA2_Baroque_XS	4/4	1	88			:
Strng	Genrl	3506	FB2_Baroque_XS	4/4	1	88			:
Strng	Genrl	3507	FC2_Baroque_XS	4/4	1	88			:
Strng	Genrl	3508	FD2_Baroque_XS	4/4	1	88			:
Strng	Genrl	3509	MA_Strings1	4/4	1	101			:
Strng	Genrl	3510	MA_Strings2	4/4	1	101			:
Strng	Genrl	3511	MA_Strings3	4/4	1	101			:
Strng	Genrl	3512	MA_Strings4	4/4	1	101			:
Strng	Genrl	3513	MA_Strings5	4/4	1	101			:
Strng	Genrl	3514	MA_Strings6	4/4	1	101			:
Strng	Genrl	3515	MA_Strings7	4/4	1	101			:
Strng	Genrl	3516	MA_Strings8	4/4	1	101			:
Strng	Genrl	3517	MA_Strings9*	4/4	2	120			:
Strng	Genrl	3518	MA_Jupiter	4/4	4	120			:
Strng	Genrl	3519	MA_StringsUp1_ES*	4/4	1	120			:
Strng	Genrl	3520	MA_StringsDown1_ES*	4/4	1	120			:
Strng	Genrl	3521	MA_StringsUp2_ES	4/4	1	120			:
Strng	Genrl	3522	MA_StringsDown2_ES	4/4	1	120			:
Strng	Genrl	3523	MA_Cello1*	4/4	2	120			Cello
Strng	Genrl	3524	MA_Cello2*	4/4	2	120			:
Strng	Genrl	3525	MA_OrchStrings	4/4	4	126			Strings
Strng	Genrl	3526	MA_OrchChord	4/4	4	126			:
Strng	Genrl	3527	MA_Pizz1	4/4	1	120			Pizzicato Strings
Strng	Genrl	3528	MA_Pizz2	4/4	1	120			:
Strng	Genrl	3529	MA_Pizz3	4/4	1	120			:
Strng	Genrl	3530	MA_Pizz4	4/4	1	124			:
Strng	Genrl	3531	MA_Pizz5	4/4	1	124			:
Strng	Genrl	3532	MA_Harp1	4/4	2	120			Harp
Strng	Genrl	3533	MA_Harp2	4/4	2	120			:
Strng	Genrl	3534	MA_Harp3	4/4	1	120			:
Strng	Genrl	3535	MA_Harp4	4/4	1	120			:
Brass	R&B	3536	MB_Funk3	4/4	2	132			Brass Section
Brass	R&B	3537	MC_Funk3	4/4	4	132			:
Brass	R&B	3538	MD_Funk3	4/4	2	132			:
Brass	R&B	3539	IA_Funk3	4/4	1	132			:
Brass	R&B	3540	FA_Funk3	4/4	1	132			:
Brass	R&B	3541	FB_Funk3	4/4	1	132			:
Brass	R&B	3542	MC_Jazz Funk 2	4/4	4	120			:
Brass	R&B	3543	MD_Jazz Funk 2 /1	4/4	4	120			:
Brass	R&B	3544	MD_Jazz Funk 2 /2	4/4	1	120			:
Brass	R&B	3545	IA_Jazz Funk 2	4/4	1	120			:
Brass	R&B	3546	FA_Jazz Funk 2	4/4	1	120			:
Brass	R&B	3547	MA_Hip Break_XS	4/4	4	98			:
Brass	R&B	3548	MB_Hip Break_XS	4/4	4	98			:
Brass	R&B	3549	MC_Hip Break_XS	4/4	4	98			:
Brass	R&B	3550	FA_Hip Break_XS	4/4	1	98			:
Brass	R&B	3551	FB_Hip Break_XS	4/4	1	98			:
Brass	R&B	3552	FC_Hip Break_XS	4/4	1	98			:
Brass	R&B	3553	BA_Hip Break_XS	4/4	1	98			:
Brass	R&B	3554	FA_Soul 2	4/4	1	120			:
Brass	R&B	3555	MA_70sChartSoul_XS	4/4	2	108			"Velo Falls"
Brass	R&B	3556	MB_70sChartSoul_XS	4/4	2	108			:
Brass	R&B	3557	MC_70sChartSoul_XS	4/4	2	108			:
Brass	R&B	3558	FA_70sChartSoul_XS	4/4	1	108			:
Brass	R&B	3559	FB_70sChartSoul_XS	4/4	1	108			:
Brass	R&B	3560	FC_70sChartSoul_XS	4/4	1	108			:
Brass	R&B	3561	BA_70sChartSoul_XS	4/4	1	108			:
Brass	R&B	3562	FC_New Gospel	4/4	2	90			Brass Section
Brass	World	3563	MB1_Salsa 2	4/4	1	123			:

Main Category	Sub Category	ARP No.	ARP Name	Time Signature	Length	Original Tempo	Accent	Random SFX	Voice Type
Brass	World	3564	MC1_Salsa 2	4/4	1	123			Brass Section
Brass	World	3565	FC1_Salsa 2	4/4	2	123			:
Brass	World	3566	MA2_Salsa 2	4/4	1	123			:
Brass	World	3567	MB2_Salsa 2	4/4	4	120			:
Brass	World	3568	MA3_Salsa 2_ES	4/4	2	123			:
Brass	World	3569	MB3_Salsa 2_ES	4/4	2	123			:
Brass	World	3570	MC3_Salsa 2_ES	4/4	2	123			:
Brass	World	3571	FA3_Salsa 2_ES	4/4	1	123			:
Brass	World	3572	FC3_Salsa 2_ES	4/4	1	123			:
Brass	World	3573	MD1_Samba	4/4	4	120			:
Brass	World	3574	IA1_Samba	4/4	2	120			:
Brass	World	3575	FC1_Samba	4/4	2	120			:
Brass	World	3576	MB2_Samba	4/4	4	120			Trombone
Brass	World	3577	MC2_Samba	4/4	4	120			:
Brass	World	3578	MC_Turkish	9/8	2	125			Mute Trumpet
Brass	Genrl	3579	MA_Orchestra_XS	4/4	4	102			French Horn
Brass	Genrl	3580	MB_Orchestra_XS	4/4	8	102			:
Brass	Genrl	3581	MC_Orchestra_XS	4/4	8	102			:
Brass	Genrl	3582	MD_Orchestra_XS	4/4	4	102			:
Brass	Genrl	3583	FA_Orchestra_XS	4/4	1	102			:
Brass	Genrl	3584	MB_Baroque_XS	4/4	4	88			Trumpet
Brass	Genrl	3585	MD_Baroque_XS	4/4	4	88			:
Brass	Genrl	3586	FA_Baroque_XS	4/4	1	88			:
Brass	Genrl	3587	FD_Baroque_XS	4/4	1	88			:
Brass	Genrl	3588	MA_Brass Sec1	4/4	1	120			Brass Section
Brass	Genrl	3589	MA_Brass Sec2	4/4	1	123			:
Brass	Genrl	3590	MA_Brass Sec3	4/4	1	120			:
Brass	Genrl	3591	MA_Brass Sec4	4/4	1	120			:
Brass	Genrl	3592	MA_Brass Sec5	4/4	1	120			:
Brass	Genrl	3593	MA_Brass Sec6	4/4	1	120			:
Brass	Genrl	3594	MA_Brass Sec7	4/4	1	120			:
RdPp	R&B	3595	MA_Club Jazz 2_XS	4/4	4	92			Sax Section
RdPp	R&B	3596	MB_Club Jazz 2_XS	4/4	4	92			:
RdPp	R&B	3597	MC_Club Jazz 2_XS	4/4	4	92			:
RdPp	R&B	3598	FA_Club Jazz 2_XS	4/4	1	92			:
RdPp	R&B	3599	FB_Club Jazz 2_XS	4/4	1	92			:
RdPp	R&B	3600	FC_Club Jazz 2_XS	4/4	1	92			:
RdPp	R&B	3601	BA_Club Jazz 2_XS	4/4	1	92			:
RdPp	R&B	3602	MA_Club Jazz 2_ES	4/4	4	92			:
RdPp	R&B	3603	MB_Club Jazz 2_ES	4/4	4	92			:
RdPp	R&B	3604	MC_Club Jazz 2_ES	4/4	4	92			:
RdPp	R&B	3605	FA_Club Jazz 2_ES	4/4	1	92			:
RdPp	R&B	3606	FB_Club Jazz 2_ES	4/4	1	92			:
RdPp	R&B	3607	FC_Club Jazz 2_ES	4/4	1	92			:
RdPp	R&B	3608	BA_Club Jazz 2_ES	4/4	1	92			:
RdPp	R&B	3609	MD_Hip Hop 1_ES	4/4	2	105			Saxophone
RdPp	R&B	3610	FC_Hip Hop 1_ES	4/4	2	105			:
RdPp	R&B	3611	MB_Soul 2_ES	4/4	4	120			:
RdPp	R&B	3612	MC_Soul 2_ES	4/4	4	120			:
RdPp	R&B	3613	FB_Soul 2_ES	4/4	1	120			:
RdPp	R&B	3614	FC_Soul 2_ES	4/4	1	120			:
RdPp	World	3615	MA_Samba_ES	4/4	2	120			:
RdPp	World	3616	MC_Samba_ES	4/4	4	120			:
RdPp	World	3617	MD_Samba_ES	4/4	4	120			:
RdPp	World	3618	FC_Samba_ES	4/4	2	120			:
RdPp	World	3619	MA1_Turkish_ES	4/4	2	105			Key
RdPp	World	3620	MF1_Turkish_ES	4/4	2	105			:
RdPp	World	3621	MB2_Turkish_ES	4/4	2	105			Saxophone
RdPp	World	3622	MC2_Turkish_ES	9/8	2	125			:
RdPp	World	3623	MD2_Turkish_ES	9/8	2	125			:
RdPp	World	3624	ME2_Turkish	4/4	2	105			:
RdPp	Genrl	3625	MC_Baroque_XS	4/4	4	88			Oboe
RdPp	Genrl	3626	MD_Baroque_XS	4/4	4	88			:
RdPp	Genrl	3627	FB_Baroque_XS	4/4	1	88			:
RdPp	Genrl	3628	FC_Baroque_XS	4/4	1	88			:
RdPp	Genrl	3629	FD_Baroque_XS	4/4	1	88			:
RdPp	Genrl	3630	Flute Accent_ES	4/4	1	102			Flute
RdPp	Genrl	3631	Flute1	4/4	1	120			:
RdPp	Genrl	3632	Flute2	4/4	1	120			:
RdPp	Genrl	3633	Flute3	4/4	1	120			:
RdPp	Genrl	3634	Flutter1	4/4	1	120			Flute/Reed
RdPp	Genrl	3635	Flutter2	4/4	1	120			:
RdPp	Genrl	3636	Flutter3	4/4	1	120			:
Lead	R&B	3637	MA_Club Jazz 1_XS	4/4	4	125			Synth Lead
Lead	R&B	3638	MB_Club Jazz 1_XS	4/4	4	125			:
Lead	R&B	3639	MC_Club Jazz 1_XS	4/4	4	125			:
Lead	R&B	3640	FA_Club Jazz 1_XS	4/4	1	125			:
Lead	R&B	3641	FB_Club Jazz 1_XS	4/4	1	125			:
Lead	R&B	3642	FC_Club Jazz 1_XS	4/4	1	125			:
Lead	R&B	3643	BA_Club Jazz 1_XS	4/4	1	125			:
Lead	R&B	3644	MA_Club Jazz 1_ES	4/4	2	125			:
Lead	R&B								

Main Category	Sub Category	ARP No.	ARP Name	Time Signature	Length	Original Tempo	Accent	Random SFX	Voice Type
Lead	R&B	3647	FA_Club Jazz 1_ES	4/4	1	125			Synth Lead
Lead	R&B	3648	FB_Club Jazz 1_ES	4/4	1	125			:
Lead	R&B	3649	FC_Club Jazz 1_ES	4/4	1	125			:
Lead	R&B	3650	BA_Club Jazz 1_ES	4/4	1	125			:
Lead	R&B	3651	MB_R&B Disco_ES	4/4	2	110			:
Lead	R&B	3652	MC_R&B Disco_ES	4/4	1	110			:
Lead	R&B	3653	MD_R&B Disco_ES	4/4	2	110			:
Lead	R&B	3654	FA_R&B Disco_ES	4/4	1	110			:
Lead	R&B	3655	FB_R&B Disco_ES	4/4	1	110			:
Lead	R&B	3656	FC_R&B Disco_ES	4/4	2	110			:
Lead	R&B	3657	MA_R&B Ballad 1_XS	4/4	4	113			:
Lead	R&B	3658	MB_R&B Ballad 1_XS	4/4	4	113			:
Lead	R&B	3659	MC_R&B Ballad 1_XS	4/4	4	113			:
Lead	R&B	3660	FA_R&B Ballad 1_XS	4/4	1	113			:
Lead	R&B	3661	FB_R&B Ballad 1_XS	4/4	1	113			:
Lead	R&B	3662	FC_R&B Ballad 1_XS	4/4	1	113			:
Lead	R&B	3663	MA_DirtySynth	4/4	2	85			:
Lead	R&B	3664	MB_DirtySynth	4/4	2	85			:
Lead	R&B	3665	MC_DirtySynth	4/4	2	85			:
Lead	R&B	3666	MD_DirtySynth	4/4	2	85			:
Lead	R&B	3667	MA_HipHopEpic/1_ES	4/4	2	85			:
Lead	R&B	3668	MA_HipHopEpic/2_ES	4/4	2	85			:
Lead	R&B	3669	MA_HipHopEpic/3_ES	4/4	2	85			:
Lead	R&B	3670	MA_HipHopEpic/4_ES	4/4	2	85			:
Lead	R&B	3671	MB_Hip Rock 1_XS	4/4	4	90			:
Lead	R&B	3672	MC_Hip Rock 1_XS	4/4	4	90			:
Lead	R&B	3673	FA_Hip Rock 1_XS	4/4	1	90			:
Lead	R&B	3674	FB_Hip Rock 1_XS	4/4	1	90			:
Lead	R&B	3675	FC_Hip Rock 1_XS	4/4	1	90			:
Lead	R&B	3676	MA_Regeton_XS	4/4	4	98			:
Lead	R&B	3677	MB_Regeton_XS	4/4	4	98			:
Lead	R&B	3678	MC_Regeton_XS	4/4	4	98			:
Lead	R&B	3679	FA_Regeton_XS	4/4	1	98			:
Lead	R&B	3680	FB_Regeton_XS	4/4	1	98			:
Lead	R&B	3681	FC_Regeton_XS	4/4	1	98			:
Lead	R&B	3682	MA_Rap Lead1	4/4	2	120			:
Lead	R&B	3683	MA_Rap Lead2	4/4	2	100			:
Lead	Elect	3684	MA_Big Beat 2_ES	4/4	4	145			:
Lead	Elect	3685	MB_Big Beat 2_ES	4/4	8	145			:
Lead	Elect	3686	MC_Big Beat 2_ES	4/4	4	145			:
Lead	Elect	3687	FA_Big Beat 2_ES	4/4	1	145			:
Lead	Elect	3688	FB_Big Beat 2_ES	4/4	1	145			:
Lead	Elect	3689	FC_Big Beat 2_ES	4/4	1	145			:
Lead	Elect	3690	BA_Big Beat 2_ES	4/4	2	145			:
Lead	Elect	3691	MA_Trance 1_XS	4/4	8	142			:
Lead	Elect	3692	MB_Trance 1_XS	4/4	4	142			:
Lead	Elect	3693	MC_Trance 1_XS	4/4	16	142			:
Lead	Elect	3694	FA_Trance 1_XS	4/4	2	142			:
Lead	Elect	3695	FB_Trance 1_XS	4/4	8	142			:
Lead	Elect	3696	FC_Trance 1_XS	4/4	8	142			:
Lead	Elect	3697	BA_Trance 1_XS	4/4	1	142			:
Lead	Elect	3698	MA_Trance 1_ES	4/4	8	142			:
Lead	Elect	3699	MB_Trance 1_ES	4/4	4	142			:
Lead	Elect	3700	MC_Trance 1_ES	4/4	16	142			:
Lead	Elect	3701	FA_Trance 1_ES	4/4	2	142			:
Lead	Elect	3702	FB_Trance 1_ES	4/4	8	142			:
Lead	Elect	3703	FC_Trance 1_ES	4/4	8	142			:
Lead	Elect	3704	BA_Trance 1_ES	4/4	1	142			:
Lead	Elect	3705	MA_Trance 3_XS	4/4	2	140			:
Lead	Elect	3706	MB_Trance 3_XS	4/4	2	140			:
Lead	Elect	3707	MC_Trance 3_XS	4/4	3	140			:
Lead	Elect	3708	FA_Trance 3_XS	4/4	2	140			:
Lead	Elect	3709	FB_Trance 3_XS	4/4	2	140			:
Lead	Elect	3710	FC_Trance 3_XS	4/4	4	140			:
Lead	Elect	3711	BA_Trance 3_XS	4/4	1	140			:
Lead	Elect	3712	MA_Trance 3_ES	4/4	2	140			:
Lead	Elect	3713	MB_Trance 3_ES	4/4	2	140			:
Lead	Elect	3714	MC_Trance 3_ES	4/4	3	140			:
Lead	Elect	3715	FA_Trance 3_ES	4/4	2	140			:
Lead	Elect	3716	FB_Trance 3_ES	4/4	2	140			:
Lead	Elect	3717	FC_Trance 3_ES	4/4	4	140			:
Lead	Elect	3718	BA_Trance 3_ES	4/4	1	140			:
Lead	Elect	3719	MA_Trance 4_XS	4/4	4	130			:
Lead	Elect	3720	MB_Trance 4_XS	4/4	2	130			:
Lead	Elect	3721	MC_Trance 4_XS	4/4	4	130			:
Lead	Elect	3722	FA_Trance 4_XS	4/4	4	130			:
Lead	Elect	3723	FB_Trance 4_XS	4/4	2	130			:
Lead	Elect	3724	FC_Trance 4_XS	4/4	4	130			:
Lead	Elect	3725	BA_Trance 4_XS	4/4	2	130			:
Lead	Elect	3726	MA_Trance 4_ES	4/4	4	130			:
Lead	Elect	3727	MB_Trance 4_ES	4/4	2	130			:
Lead	Elect	3728	MC_Trance 4_ES	4/4	4	130			:
Lead	Elect	3729	FA_Trance 4_ES	4/4	4	130			:

Main Category	Sub Category	ARP No.	ARP Name	Time Signature	Length	Original Tempo	Accent	Random SFX	Voice Type
Lead	Elect	3730	FB_Trance 4_ES	4/4	2	130			Synth Lead
Lead	Elect	3731	FC_Trance 4_ES	4/4	4	130			:
Lead	Elect	3732	BA_Trance 4_ES	4/4	2	130			:
Lead	Elect	3733	MA_Trance Lead1_ES	4/4	8	143			:
Lead	Elect	3734	MA_Trance Lead2_ES	4/4	2	143			:
Lead	Elect	3735	MA_Trance Lead3_ES	4/4	2	143			:
Lead	Elect	3736	MA_Trance Lead4_ES	4/4	1	143			:
Lead	Elect	3737	MA_Trance Lead5_ES	4/4	2	143			:
Lead	Elect	3738	MA_Psyche Lead1_ES	4/4	1	143			:
Lead	Elect	3739	MA_Psyche Lead2_ES	4/4	1	143			:
Lead	Elect	3740	MA_Psyche Lead3_ES	4/4	1	143			:
Lead	Elect	3741	MA_Psyche Lead4_ES	4/4	2	143			:
Lead	Elect	3742	MA_Psyche Lead5_ES	4/4	2	143			:
Lead	Genrl	3743	MA_Needlz	4/4	2	132			:
Lead	Genrl	3744	MA_Pretzel	4/4	1	120			:
Lead	Genrl	3745	MA_DitDot	4/4	2	145			:
Lead	Genrl	3746	MA_CurlyQ	4/4	1	145			:
Lead	Genrl	3747	MA_Springo	4/4	2	120			:
Lead	Genrl	3748	MA_Bouncy	4/4	1	138			:
PdMe	Rock	3749	MA_16BeatBasic2_XS	4/4	4	77			Synth Pad
PdMe	Rock	3750	MB_16BeatBasic2_XS	4/4	4	77			:
PdMe	Rock	3751	MC_16BeatBasic2_XS	4/4	4	77			:
PdMe	Rock	3752	FA_16BeatBasic2_XS	4/4	1	77			:
PdMe	Rock	3753	FB_16BeatBasic2_XS	4/4	1	77			:
PdMe	Rock	3754	FC_16BeatBasic2_XS	4/4	1	77			:
PdMe	Rock	3755	BA_16BeatBasic2_XS	4/4	1	77			:
PdMe	Rock	3756	MA_16BeatBasic2_ES	4/4	4	77			:
PdMe	Rock	3757	MB_16BeatBasic2_ES	4/4	4	77			:
PdMe	Rock	3758	MC_16BeatBasic2_ES	4/4	4	77			:
PdMe	Rock	3759	FA_16BeatBasic2_ES	4/4	1	77			:
PdMe	Rock	3760	FB_16BeatBasic2_ES	4/4	1	77			:
PdMe	Rock	3761	FC_16BeatBasic2_ES	4/4	1	77			:
PdMe	Rock	3762	BA_16BeatBasic2_ES	4/4	1	77			:
PdMe	Rock	3763	MA_16Beat Pop 1_XS	4/4	4	103			:
PdMe	Rock	3764	MB_16Beat Pop 1_XS	4/4	4	103			:
PdMe	Rock	3765	MC_16Beat Pop 1_XS	4/4	4	103			:
PdMe	Rock	3766	FA_16Beat Pop 1_XS	4/4	1	103			:
PdMe	Rock	3767	FB_16Beat Pop 1_XS	4/4	1	103			:
PdMe	Rock	3768	FC_16Beat Pop 1_XS	4/4	1	103			:
PdMe	Rock	3769	BA_16Beat Pop 1_XS	4/4	1	103			:
PdMe	Rock	3770	MA_16Beat Pop 1_ES	4/4	4	103			:
PdMe	Rock	3771	MB_16Beat Pop 1_ES	4/4	4	103			:
PdMe	Rock	3772	MC_16Beat Pop 1_ES	4/4	4	103			:
PdMe	Rock	3773	FA_16Beat Pop 1_ES	4/4	1	103			:
PdMe	Rock	3774	FB_16Beat Pop 1_ES	4/4	1	103			:
PdMe	Rock	3775	FC_16Beat Pop 1_ES	4/4	1	103			:
PdMe	Rock	3776	BA_16Beat Pop 1_ES	4/4	1	103			:
PdMe	Rock	3777	MA_16Beat Pop 2_XS	4/4	4	94			:
PdMe	Rock	3778	MB_16Beat Pop 2_XS	4/4	4	94			:
PdMe	Rock	3779	MC_16Beat Pop 2_XS	4/4	4	94			:
PdMe	Rock	3780	FA_16Beat Pop 2_XS	4/4	1	94			:
PdMe	Rock	3781	FB_16Beat Pop 2_XS	4/4	1	94			:
PdMe	Rock	3782	FC_16Beat Pop 2_XS	4/4	1	94			:
PdMe	Rock	3783	BA_16Beat Pop 2_XS	4/4	1	94			:
PdMe	Rock	3784	MA_16Beat Pop 2_ES	4/4	4	94			:
PdMe	Rock	3785	MB_16Beat Pop 2_ES	4/4	4	94			:
PdMe	Rock	3786	MC_16Beat Pop 2_ES	4/4	4	94			:
PdMe	Rock	3787	FA_16Beat Pop 2_ES	4/4	1	94			:
PdMe	Rock	3788	FB_16Beat Pop 2_ES	4/4	1	94			:
PdMe	Rock	3789	FC_16Beat Pop 2_ES	4/4	1	94			:
PdMe	Rock	3790	BA_16Beat Pop 2_ES	4/4	1	94			:
PdMe	Rock	3791	MA_16Beat Rock_XS	4/4	4	86			:
PdMe	Rock	3792	MB_16Beat Rock_XS	4/4	4	86			:
PdMe	Rock	3793	MC_16Beat Rock_XS	4/4	4	86			:
PdMe	Rock	3794	FA_16Beat Rock_XS	4/4	1	86			:
PdMe	Rock	3795	FB_16Beat Rock_XS	4/4	1	86			:
PdMe	Rock	3796	FC_16Beat Rock_XS	4/4	1	86			:
PdMe	Rock	3797	BA_16Beat Rock_XS	4/4	1	86			:
PdMe	Rock	3798	MA_16Beat Rock_ES	4/4	4	86			:
PdMe	Rock	3799	MB_16Beat Rock_ES	4/4	4	86			:
PdMe	Rock	3800	MC_16Beat Rock_ES	4/4	4	86			:
PdMe	Rock	3801	FA_16Beat Rock_ES	4/4	1	86			:
PdMe	Rock	3802	FB_16Beat Rock_ES	4/4	1	86			:
PdMe	Rock	3803	FC_16Beat Rock_ES	4/4	1	86			:
PdMe	Rock	3804	BA_16Beat Rock_ES	4/4	1	86			:
PdMe	Rock	3805	MC_Analog Pop	4/4	1	93			:
PdMe	Rock	3806	MD_Analog Pop	4/4	1	93			:
PdMe	R&B	3807	MA_Pop Shuffle2_XS	4/4	4	80			:
PdMe	R&B	3808	MB_Pop Shuffle2_XS	4/4	4	80			:
PdMe	R&B	3809	MC_Pop Shuffle2_XS	4/4	4	80			:
PdMe	R&B	3810	FA_Pop Shuffle2_XS	4/4	1	80			:
PdMe	R&B	3811	FB_Pop Shuffle2_XS	4/4	1	80			:
PdMe	R&B	3812	FC_Pop Shuffle2_XS</						

Arpeggio Type List

Main Category	Sub Category	ARP No.	ARP Name	Time Signature	Length	Original Tempo	Accent	Random SFX	Voice Type
PdMe	R&B	3813	BA_Pop Shuffle2_XS	4/4	1	80			Synth Lead
PdMe	R&B	3814	MA_Pop Shuffle2_ES	4/4	4	80			:
PdMe	R&B	3815	MB_Pop Shuffle2_ES	4/4	4	80			:
PdMe	R&B	3816	MC_Pop Shuffle2_ES	4/4	4	80			:
PdMe	R&B	3817	FA_Pop Shuffle2_ES	4/4	1	80			:
PdMe	R&B	3818	FB_Pop Shuffle2_ES	4/4	1	80			:
PdMe	R&B	3819	FC_Pop Shuffle2_ES	4/4	1	80			:
PdMe	R&B	3820	BA_Pop Shuffle2_ES	4/4	1	80			:
PdMe	R&B	3821	MA_Chart R&B_XS	4/4	4	130			:
PdMe	R&B	3822	MB_Chart R&B_XS	4/4	4	130			:
PdMe	R&B	3823	MC_Chart R&B_XS	4/4	4	130			:
PdMe	R&B	3824	FA_Chart R&B_XS	4/4	1	130			:
PdMe	R&B	3825	FB_Chart R&B_XS	4/4	1	130			:
PdMe	R&B	3826	FC_Chart R&B_XS	4/4	1	130			:
PdMe	R&B	3827	BA_Chart R&B_XS	4/4	1	130			:
PdMe	R&B	3828	MA_J-R&B Pop_XS	4/4	4	100			Hit
PdMe	R&B	3829	MB_J-R&B Pop_XS	4/4	4	100			:
PdMe	R&B	3830	MC_J-R&B Pop_XS	4/4	4	100			:
PdMe	R&B	3831	FA_J-R&B Pop_XS	4/4	1	100			:
PdMe	R&B	3832	FB_J-R&B Pop_XS	4/4	1	100			:
PdMe	R&B	3833	BA_J-R&B Pop_XS	4/4	1	100			:
PdMe	R&B	3834	MD_Smooth 1	4/4	2	115			Synth Pad
PdMe	R&B	3835	FC_Smooth 1	4/4	2	115			:
PdMe	R&B	3836	IA_Hip Hop 2	4/4	1	94			Hit
PdMe	R&B	3837	FC_Hip Hop 2_ES	4/4	2	94			:
PdMe	Elect	3838	MA1_Techno 1_ES	4/4	4	135			Synth Pad
PdMe	Elect	3839	MB1_Techno 1_ES	4/4	8	135			:
PdMe	Elect	3840	MC1_Techno 1_ES	4/4	8	135			:
PdMe	Elect	3841	FA1_Techno 1_ES	4/4	1	135			:
PdMe	Elect	3842	FB1_Techno 1_ES	4/4	1	135			:
PdMe	Elect	3843	BA1_Techno 1_ES	4/4	4	135			:
PdMe	Elect	3844	MC2_Techno 1_ES	4/4	8	135			:
PdMe	Genrl	3845	MA_Cycle1	4/4	3	120			:
PdMe	Genrl	3846	MA_Cycle2	4/4	6	120			:
PdMe	Genrl	3847	MA_Cycle3_ES	4/4	14	118			:
PdMe	Genrl	3848	MA_Ripples_ES	4/4	4	82			:
PdMe	Genrl	3849	MA_PulsPad	4/4	4	120			:
CPrc	R&B	3850	FB_R&B Disco_ES	4/4	1	110			Chromatic Perc.
CPrc	R&B	3851	FC_R&B Disco_ES	4/4	2	110			:
CPrc	Elect	3852	MC_Trance 5	4/4	4	140			:
CPrc	World	3853	MA_Ethnic1	6/4	5	118			:
CPrc	World	3854	MA_Ethnic2	7/4	3	120			:
CPrc	Genrl	3855	MOD1	4/4	1	120			:
CPrc	Genrl	3856	MOD2	4/4	2	120			:
CPrc	Genrl	3857	MOD3	4/4	1	120			:
CPrc	Genrl	3858	Trill 1	4/4	1	120			:
CPrc	Genrl	3859	Trill 2	4/4	2	120			:
CPrc	Genrl	3860	Trill 3	4/4	2	120			:
CPrc	Genrl	3861	Mallet Roll1	4/4	2	120			:
CPrc	Genrl	3862	Mallet Roll2	4/4	2	120			:
CPrc	Genrl	3863	Timpani Roll_ES	4/4	1	102			Timpani
CPrc	Genrl	3864	Steel Drum1	4/4	1	160			Steel Drum
CPrc	Genrl	3865	Steel Drum2	4/4	2	95			:
CPrc	Genrl	3866	Bell Tree1	4/4	3	120			Chromatic Perc.
CPrc	Genrl	3867	Bell Tree2	4/4	3	120			:
CPrc	Genrl	3868	Crescendo	4/4	1	120			:
DrPc	Rock	3869	MA_StandardRock	4/4	4	131	○		"Power Standard Kit 2"
DrPc	Rock	3870	MB_StandardRock	4/4	4	131	○		:
DrPc	Rock	3871	MC_StandardRock	4/4	4	131	○		:
DrPc	Rock	3872	FA_StandardRock	4/4	1	131	○		:
DrPc	Rock	3873	FB_StandardRock	4/4	1	131	○		:
DrPc	Rock	3874	FC_StandardRock	4/4	1	131	○		:
DrPc	Rock	3875	BA_StandardRock	4/4	1	131	○		:
DrPc	Rock	3876	MA_Power Rock	4/4	4	120	○		"Power Standard Kit 1"
DrPc	Rock	3877	MB_Power Rock	4/4	4	120	○		:
DrPc	Rock	3878	MC_Power Rock	4/4	4	120	○		:
DrPc	Rock	3879	FA_Power Rock	4/4	1	120	○		:
DrPc	Rock	3880	FB_Power Rock	4/4	1	120	○		:
DrPc	Rock	3881	FC_Power Rock	4/4	1	120	○		:
DrPc	Rock	3882	BA_Power Rock	4/4	1	120	○		:
DrPc	Rock	3883	MA_ContempRock	4/4	4	126	○		"Power Standard Kit 2"
DrPc	Rock	3884	MB_ContempRock	4/4	4	126	○		:
DrPc	Rock	3885	MC_ContempRock	4/4	4	126	○		:
DrPc	Rock	3886	FA_ContempRock	4/4	1	126	○		:
DrPc	Rock	3887	FB_ContempRock	4/4	1	126	○		:
DrPc	Rock	3888	FC_ContempRock	4/4	1	126	○		:
DrPc	Rock	3889	BA_ContempRock	4/4	1	126	○		:
DrPc	Rock	3890	MA_Hard Rock	4/4	4	120	○		"Power Standard Kit 1"
DrPc	Rock	3891	MB_Hard Rock	4/4	4	120	○		:
DrPc	Rock	3892	MC_Hard Rock	4/4	4	120	○		:
DrPc	Rock	3893	FA_Hard Rock	4/4	1	120	○		:
DrPc	Rock	3894	FB_Hard Rock	4/4	1	120	○		:
DrPc	Rock	3895	FC_Hard Rock	4/4	1	120	○		:

Main Category	Sub Category	ARP No.	ARP Name	Time Signature	Length	Original Tempo	Accent	Random SFX	Voice Type
DrPc	Rock	3896	BA_Hard Rock	4/4	1	120	○		"Power Standard Kit 1"
DrPc	Rock	3897	MA_70s Rock	4/4	4	130	○		"Dry Standard Kit"
DrPc	Rock	3898	MB_70s Rock	4/4	4	130	○		:
DrPc	Rock	3899	MC_70s Rock	4/4	4	130	○		:
DrPc	Rock	3900	MD_70s Rock	4/4	4	130	○		:
DrPc	Rock	3901	IA_70s Rock	4/4	1	130	○		:
DrPc	Rock	3902	FA_70s Rock	4/4	1	130	○		:
DrPc	Rock	3903	FB_70s Rock	4/4	1	130	○		:
DrPc	Rock	3904	FC_70s Rock	4/4	2	130	○		:
DrPc	Rock	3905	MA_Blues Rock	4/4	4	120	○		"Power Standard Kit 1"
DrPc	Rock	3906	MB_Blues Rock	4/4	4	120	○		:
DrPc	Rock	3907	MC_Blues Rock	4/4	4	120	○		:
DrPc	Rock	3908	FA_Blues Rock	4/4	1	120	○		:
DrPc	Rock	3909	FB_Blues Rock	4/4	1	120	○		:
DrPc	Rock	3910	FC_Blues Rock	4/4	1	120	○		:
DrPc	Rock	3911	BA_Blues Rock	4/4	1	120	○		:
DrPc	Rock	3912	MA_Rock & Roll	4/4	4	172	○		"Power Standard Kit 2"
DrPc	Rock	3913	MB_Rock & Roll	4/4	4	172	○		:
DrPc	Rock	3914	MC_Rock & Roll	4/4	4	172	○		:
DrPc	Rock	3915	FA_Rock & Roll	4/4	1	172	○		:
DrPc	Rock	3916	FB_Rock & Roll	4/4	1	172	○		:
DrPc	Rock	3917	FC_Rock & Roll	4/4	1	172	○		:
DrPc	Rock	3918	BA_Rock & Roll	4/4	1	172	○		:
DrPc	Rock	3919	MA1_AlternaRock1	4/4	4	97	○		"Modern Rock Kit"
DrPc	Rock	3920	MB1_AlternaRock1	4/4	4	97	○		:
DrPc	Rock	3921	MC1_AlternaRock1	4/4	4	97	○		:
DrPc	Rock	3922	FA1_AlternaRock1	4/4	1	97	○		:
DrPc	Rock	3923	FB1_AlternaRock1	4/4	1	97	○		:
DrPc	Rock	3924	FC1_AlternaRock1	4/4	1	97	○		:
DrPc	Rock	3925	BA1_AlternaRock1	4/4	1	97	○		:
DrPc	Rock	3926	MA2_8Z Alterna1	4/4	4	97	○		"8Z Romps"
DrPc	Rock	3927	MB2_8Z Alterna1	4/4	4	97	○		:
DrPc	Rock	3928	MC2_8Z Alterna1	4/4	4	97	○		:
DrPc	Rock	3929	FA2_8Z Alterna1	4/4	1	97	○		:
DrPc	Rock	3930	FB2_8Z Alterna1	4/4	1	97	○		:
DrPc	Rock	3931	FC2_8Z Alterna1	4/4	1	97	○		:
DrPc	Rock	3932	BA2_8Z Alterna1	4/4	1	97	○		:
DrPc	Rock	3933	MA_AlternaRock2	4/4	4	100	○		"Rock Stereo Kit 2"
DrPc	Rock	3934	MB_AlternaRock2	4/4	4	100	○		:
DrPc	Rock	3935	MC_AlternaRock2	4/4	4	100	○		:
DrPc	Rock	3936	FA_AlternaRock2	4/4	1	100	○		:
DrPc	Rock	3937	FB_AlternaRock2	4/4	1	100	○		:
DrPc	Rock	3938	FC_AlternaRock2	4/4	1	100	○		:
DrPc	Rock	3939	BA_AlternaRock2	4/4	2	100	○		:
DrPc	Rock	3940	MA_Mondo Rock	4/4	2	94	○		:
DrPc	Rock	3941	MB_Mondo Rock	4/4	2	94	○		:
DrPc	Rock	3942	MC_Mondo Rock	4/4	2	94	○		:
DrPc	Rock	3943	MD_Mondo Rock	4/4	4	94	○		:
DrPc	Rock	3944	MA1_Xover Rock	4/4	2	100	○		"Rock Stereo Kit 1"
DrPc	Rock	3945	MB1_Xover Rock	4/4	1	100	○		:
DrPc	Rock	3946	MC1_Xover Rock	4/4	2	100	○		:
DrPc	Rock	3947	MD1_Xover Rock	4/4	2	100	○		:
DrPc	Rock	3948	IA1_Xover Rock	4/4	2	100	○		:
DrPc	Rock	3949	FA1_Xover Rock	4/4	1	100	○		:
DrPc	Rock	3950	FB1_Xover Rock	4/4	1	100	○		:
DrPc	Rock	3951	FC1_Xover Rock	4/4	2	100	○		:
DrPc	Rock	3952	FA2_Xover Rock	4/4	1	100	○		"Scratches"
DrPc	Rock	3953	FC2_Xover Rock	4/4	1	100	○		:
DrPc	Rock	3954	MA_Pop Rock 1	4/4	2	120	○		"Rock Stereo Kit 2"
DrPc	Rock	3955	MB_Pop Rock 1	4/4	2	120	○		:
DrPc	Rock	3956	MC_Pop Rock 1	4/4	2	120	○		:
DrPc	Rock	3957	MD_Pop Rock 1	4/4	2	120	○		:
DrPc	Rock	3958	MA_Pop Rock 2	4/4	2	126	○		"Rock Stereo Kit 1"
DrPc	Rock	3959	MB_Pop Rock 2	4/4	2	126	○		:
DrPc	Rock	3960	MC_Pop Rock 2	4/4	2	126	○		:
DrPc	Rock	3961	MD_Pop Rock 2	4/4	2	126	○		:
DrPc	Rock	3962	MA_Pop Rock 3	4/4	2	120	○		"Rock Stereo Kit 2"
DrPc	Rock	3963	MA_Pop Rock 4	4/4	2	115	○		:
DrPc	Rock	3964	MA_Guitar Pop 1	4/4	4	100	○		"Power Standard Kit 1"
DrPc	Rock	3965	MB_Guitar Pop 1	4/4	4	100	○		:
DrPc	Rock	3966	MC_Guitar Pop 1	4/4	4	100	○		:
DrPc	Rock	3967	FA_Guitar Pop 1	4/4	1	100	○		:
DrPc	Rock	3968	FB_Guitar Pop 1	4/4	1	100	○		:
DrPc	Rock	3969	FC_Guitar Pop 1	4/4	1	100	○		:
DrPc	Rock	3970	BA_Guitar Pop 1	4/4	1	100	○		:
DrPc	Rock	3971	MA1_Guitar Pop 2	4/4	2	90	○		"Dry Standard Kit"
DrPc	Rock	3972	MB1_Guitar Pop 2	4/4	1	90	○		:
DrPc	Rock	3973	MC1_Guitar Pop 2	4/4	2	90	○		:
DrPc	Rock	3974	MD1_Guitar Pop 2	4/4	2	9			

Arpeggio Type List

Main Category	Sub Category	ARP No.	ARP Name	Time Signature	Length	Original Tempo	Accent	Random SFX	Voice Type
DrPc	Rock	3979	MC2_Guitar Pop 2	4/4	2	90	○		"Latin Percussion Kit"
DrPc	Rock	3980	MD2_Guitar Pop 2	4/4	2	90	○		:
DrPc	Rock	3981	FA2_Guitar Pop 2	4/4	1	90	○		:
DrPc	Rock	3982	FC2_Guitar Pop 2	4/4	2	90	○		:
DrPc	Rock	3983	MA_Acoustic Pop	4/4	4	110	○		"Chill Out Kit"
DrPc	Rock	3984	MB_Acoustic Pop	4/4	4	110	○		:
DrPc	Rock	3985	MC_Acoustic Pop	4/4	4	110	○		:
DrPc	Rock	3986	FA_Acoustic Pop	4/4	1	110	○		:
DrPc	Rock	3987	FB_Acoustic Pop	4/4	1	110	○		:
DrPc	Rock	3988	FC_Acoustic Pop	4/4	1	110	○		:
DrPc	Rock	3989	BA_Acoustic Pop	4/4	1	110	○		:
DrPc	Rock	3990	MA_GuitarBallad	4/4	8	94	○		"Power Standard Kit 1"
DrPc	Rock	3991	MB_GuitarBallad	4/4	8	94	○		:
DrPc	Rock	3992	MC_GuitarBallad	4/4	8	94	○		:
DrPc	Rock	3993	FA_GuitarBallad	4/4	1	94	○		:
DrPc	Rock	3994	FB_GuitarBallad	4/4	1	94	○		:
DrPc	Rock	3995	FC_GuitarBallad	4/4	1	94	○		:
DrPc	Rock	3996	BA_GuitarBallad	4/4	1	94	○		:
DrPc	Rock	3997	MA_Unplugged 1	4/4	4	120	○		:
DrPc	Rock	3998	MB_Unplugged 1	4/4	4	120	○		:
DrPc	Rock	3999	MC_Unplugged 1	4/4	4	120	○		:
DrPc	Rock	4000	FA_Unplugged 1	4/4	1	120	○		:
DrPc	Rock	4001	FB_Unplugged 1	4/4	1	120	○		:
DrPc	Rock	4002	FC_Unplugged 1	4/4	1	120	○		:
DrPc	Rock	4003	BA_Unplugged 1	4/4	1	120	○		:
DrPc	Rock	4004	MA1_Unplugged 2	4/4	8	120	○		:
DrPc	Rock	4005	MB1_Unplugged 2	4/4	8	120	○		:
DrPc	Rock	4006	MC1_Unplugged 2	4/4	8	120	○		:
DrPc	Rock	4007	FA1_Unplugged 2	4/4	1	120	○		:
DrPc	Rock	4008	FB1_Unplugged 2	4/4	1	120	○		:
DrPc	Rock	4009	FC1_Unplugged 2	4/4	1	120	○		:
DrPc	Rock	4010	BA1_Unplugged 2	4/4	1	120	○		:
DrPc	Rock	4011	MA2_Unplugged 2	4/4	8	120	○		:
DrPc	Rock	4012	MB2_Unplugged 2	4/4	8	120	○		:
DrPc	Rock	4013	MC2_Unplugged 2	4/4	8	120	○		:
DrPc	Rock	4014	FA2_Unplugged 2	4/4	1	120	○		:
DrPc	Rock	4015	FB2_Unplugged 2	4/4	1	120	○		:
DrPc	Rock	4016	FC2_Unplugged 2	4/4	1	120	○		:
DrPc	Rock	4017	BA2_Unplugged 2	4/4	1	120	○		:
DrPc	Rock	4018	MA_Unplugged 3	4/4	4	113	○		"Power Standard Kit 2"
DrPc	Rock	4019	MB_Unplugged 3	4/4	4	113	○		:
DrPc	Rock	4020	MC_Unplugged 3	4/4	4	113	○		:
DrPc	Rock	4021	FA_Unplugged 3	4/4	1	113	○		:
DrPc	Rock	4022	FB_Unplugged 3	4/4	1	113	○		:
DrPc	Rock	4023	FC_Unplugged 3	4/4	1	113	○		:
DrPc	Rock	4024	BA_Unplugged 3	4/4	1	113	○		:
DrPc	Rock	4025	MA_Unplugged 4	4/4	4	120	○		"Dry Standard Kit"
DrPc	Rock	4026	MB_Unplugged 4	4/4	4	120	○		:
DrPc	Rock	4027	MC_Unplugged 4	4/4	4	120	○		:
DrPc	Rock	4028	MD_Unplugged 4	4/4	4	120	○		:
DrPc	Rock	4029	IA_Unplugged 4	4/4	1	120	○		:
DrPc	Rock	4030	FA_Unplugged 4	4/4	1	120	○		:
DrPc	Rock	4031	FB_Unplugged 4	4/4	1	120	○		:
DrPc	Rock	4032	FC_Unplugged 4	4/4	1	120	○		:
DrPc	Rock	4033	MA_FingerPickin	4/4	4	94	○		:
DrPc	Rock	4034	MB_FingerPickin	4/4	4	94	○		:
DrPc	Rock	4035	MC_FingerPickin	4/4	4	94	○		:
DrPc	Rock	4036	MD_FingerPickin	4/4	4	94	○		:
DrPc	Rock	4037	IA_FingerPickin/a	4/4	1	94	○		:
DrPc	Rock	4038	IA_FingerPickin/b	4/4	1	94	○		:
DrPc	Rock	4039	FA_FingerPickin	4/4	1	94	○		:
DrPc	Rock	4040	FB_FingerPickin	4/4	1	94	○		:
DrPc	Rock	4041	FC_FingerPickin	4/4	1	94	○		:
DrPc	Rock	4042	MA_Folk Rock	4/4	1	120	○		:
DrPc	Rock	4043	MB_Folk Rock/1	4/4	4	120	○		:
DrPc	Rock	4044	MD_Folk Rock	4/4	1	120	○		:
DrPc	Rock	4045	IA_Folk Rock	4/4	1	120	○		:
DrPc	Rock	4046	FA_Folk Rock	4/4	1	120	○		:
DrPc	Rock	4047	FB_Folk Rock	4/4	1	120	○		:
DrPc	Rock	4048	FC_Folk Rock	4/4	1	120	○		:
DrPc	Rock	4049	MB_Folk Rock/2	4/4	1	120	○		:
DrPc	Rock	4050	MA_Worship Slow	4/4	4	75	○		"Power Standard Kit 1"
DrPc	Rock	4051	MB_Worship Slow	4/4	4	75	○		:
DrPc	Rock	4052	MC_Worship Slow	4/4	4	75	○		:
DrPc	Rock	4053	FA_Worship Slow	4/4	1	75	○		:
DrPc	Rock	4054	FB_Worship Slow	4/4	1	75	○		:
DrPc	Rock	4055	FC_Worship Slow	4/4	1	75	○		:
DrPc	Rock	4056	BA_Worship Slow	4/4	1	75	○		:
DrPc	Rock	4057	MA_Worship Med	4/4	8	140	○		"Brush Kit"
DrPc	Rock	4058	MB_Worship Med	4/4	4	140	○		:
DrPc	Rock	4059	MC_Worship Med	4/4	4	140	○		:
DrPc	Rock	4060	FA_Worship Med	4/4	1	140	○		:
DrPc	Rock	4061	FB_Worship Med	4/4	1	140	○		:

Main Category	Sub Category	ARP No.	ARP Name	Time Signature	Length	Original Tempo	Accent	Random SFX	Voice Type
DrPc	Rock	4062	FC_Worship Med	4/4	1	140	○		"Brush Kit"
DrPc	Rock	4063	BA_Worship Med	4/4	1	140	○		:
DrPc	Rock	4064	MA_Worship Fast	4/4	8	114	○		"Power Standard Kit 2"
DrPc	Rock	4065	MB_Worship Fast	4/4	4	114	○		:
DrPc	Rock	4066	MC_Worship Fast	4/4	4	114	○		:
DrPc	Rock	4067	FA_Worship Fast	4/4	1	114	○		:
DrPc	Rock	4068	FB_Worship Fast	4/4	1	114	○		:
DrPc	Rock	4069	FC_Worship Fast	4/4	1	114	○		:
DrPc	Rock	4070	BA_Worship Fast	4/4	1	114	○		:
DrPc	Rock	4071	MA_New Country	4/4	2	118	○		"Power Standard Kit 1"
DrPc	Rock	4072	MB_New Country	4/4	4	118	○		:
DrPc	Rock	4073	MC_New Country	4/4	2	118	○		:
DrPc	Rock	4074	FA_New Country	4/4	1	118	○		:
DrPc	Rock	4075	FB_New Country	4/4	1	118	○		:
DrPc	Rock	4076	FC_New Country	4/4	1	118	○		:
DrPc	Rock	4077	BA_New Country	4/4	1	118	○		:
DrPc	Rock	4078	MA_VintageGIPop	4/4	4	148	○		:
DrPc	Rock	4079	MB_VintageGIPop	4/4	4	148	○		:
DrPc	Rock	4080	MC_VintageGIPop	4/4	4	148	○		:
DrPc	Rock	4081	FA_VintageGIPop	4/4	1	148	○		:
DrPc	Rock	4082	FB_VintageGIPop	4/4	1	148	○		:
DrPc	Rock	4083	FC_VintageGIPop	4/4	1	148	○		:
DrPc	Rock	4084	BA_VintageGIPop	4/4	1	148	○		:
DrPc	Rock	4085	MA_WestCoastPop	4/4	4	100	○		:
DrPc	Rock	4086	MB_WestCoastPop	4/4	4	100	○		:
DrPc	Rock	4087	MC_WestCoastPop	4/4	4	100	○		:
DrPc	Rock	4088	FA_WestCoastPop	4/4	1	100	○		:
DrPc	Rock	4089	FB_WestCoastPop	4/4	1	100	○		:
DrPc	Rock	4090	FC_WestCoastPop	4/4	1	100	○		:
DrPc	Rock	4091	BA_WestCoastPop	4/4	1	100	○		:
DrPc	Rock	4092	MA_Brit Pop	4/4	2	86	○		"Brush Kit"
DrPc	Rock	4093	MB_Brit Pop	4/4	2	86	○		:
DrPc	Rock	4094	MC_Brit Pop	4/4	2	86	○		:
DrPc	Rock	4095	FA_Brit Pop	4/4	1	86	○		:
DrPc	Rock	4096	FB_Brit Pop	4/4	1	86	○		:
DrPc	Rock	4097	FC_Brit Pop	4/4	1	86	○		:
DrPc	Rock	4098	BA_Brit Pop	4/4	1	86	○		:
DrPc	Rock	4099	MA_BritPopSwing	4/4	2	110	○		"Power Standard Kit 1"
DrPc	Rock	4100	MB_BritPopSwing	4/4	2	110	○		:
DrPc	Rock	4101	MC_BritPopSwing	4/4	2	110	○		:
DrPc	Rock	4102	FA_BritPopSwing	4/4	1	110	○		:
DrPc	Rock	4103	FB_BritPopSwing	4/4	1	110	○		:
DrPc	Rock	4104	FC_BritPopSwing	4/4	1	110	○		:
DrPc	Rock	4105	BA_BritPopSwing	4/4	1	110	○		:
DrPc	Rock	4106	MA_8Beat Ballad	4/4	4	101	○		"Brush Kit"
DrPc	Rock	4107	MB_8Beat Ballad	4/4	4	101	○		:
DrPc	Rock	4108	MC_8Beat Ballad	4/4	4	101	○		:
DrPc	Rock	4109	FA_8Beat Ballad	4/4	1	101	○		:
DrPc	Rock	4110	FB_8Beat Ballad	4/4	1	101	○		:
DrPc	Rock	4111	FC_8Beat Ballad	4/4	1	101	○		:
DrPc	Rock	4112	BA_8Beat Ballad	4/4	1	101	○		:
DrPc	Rock	4113	MA_EP Ballad	4/4	2	60	○		"Power Standard Kit 2"
DrPc	Rock	4114	MB_EP Ballad	4/4	2	60	○		:
DrPc	Rock	4115	MC_EP Ballad	4/4	2	60	○		:
DrPc	Rock	4116	FA_EP Ballad	4/4	1	60	○		:
DrPc	Rock	4117	FB_EP Ballad	4/4	1	60	○		:
DrPc	Rock	4118	FC_EP Ballad	4/4	1	60	○		:
DrPc	Rock	4119	BA_EP Ballad	4/4	1	60	○		:
DrPc	Rock	4120	MA_Ballad 1	4/4	2	72	○		"Hyper Standard Kit"
DrPc	Rock	4121	MB_Ballad 1	4/4	2	72	○		:
DrPc	Rock	4122	MA_Ballad 2	4/4	2	72	○		:
DrPc	Rock	4123	MB_Ballad 2	4/4	2	72	○		:
DrPc	Rock	4124	MA_Ballad 3	4/4	2	72	○		:
DrPc	Rock	4125	MB_Ballad 3	4/4	1	72	○		:
DrPc	Rock	4126	MA_Cool 8Beat	4/4	2	100	○		"Power Standard Kit 1"
DrPc	Rock	4127	MB_Cool 8Beat	4/4	2	100	○		:
DrPc	Rock	4128	MC_Cool 8Beat	4/4	2	100	○		:
DrPc	Rock	4129	FA_Cool 8Beat	4/4	1	100	○		:
DrPc	Rock	4130	FB_Cool 8Beat	4/4	1	100	○		:
DrPc	Rock	4131	FC_Cool 8Beat	4/4	1	100	○		:
DrPc	Rock	4132	BA_Cool 8Beat	4/4	1	100	○		:
DrPc	Rock	4133	MA_8Beat Basic	4/4	4	120	○		:
DrPc	Rock	4134	MB_8Beat Basic	4/4	4	120	○		:
DrPc	Rock	4135	MC_8Beat Basic	4/4	4	120	○		:
DrPc	Rock	4136	FA_8Beat Basic	4/4	1	120	○		:
DrPc	Rock	4137	FB_8Beat Basic	4/4	1	120	○		:
DrPc	Rock	4138	FC_8Beat Basic	4/4	1	120	○		:
DrPc	Rock	4139	BA_8Beat Basic	4/4	1	120	○		:
DrPc	Rock	4140	MA_8Beat Rock	4/4	4	7			

Arpeggio Type List

Main Category	Sub Category	ARP No.	ARP Name	Time Signature	Length	Original Tempo	Accent	Random SFX	Voice Type
DrPc	Rock	4145	FC_8Beat Rock	4/4	1	75	○		"Power Standard Kit 2"
DrPc	Rock	4146	BA_8Beat Rock	4/4	1	75	○		:
DrPc	Rock	4147	MA_8Beat Slow	4/4	4	78	○		:
DrPc	Rock	4148	MB_8Beat Slow	4/4	4	78	○		:
DrPc	Rock	4149	MC_8Beat Slow	4/4	4	78	○		:
DrPc	Rock	4150	FA_8Beat Slow	4/4	1	78	○		:
DrPc	Rock	4151	FB_8Beat Slow	4/4	1	78	○		:
DrPc	Rock	4152	FC_8Beat Slow	4/4	1	78	○		:
DrPc	Rock	4153	BA_8Beat Slow	4/4	1	78	○		:
DrPc	Rock	4154	MA_8Beat Soft	4/4	4	100	○		"Power Standard Kit 1"
DrPc	Rock	4155	MB_8Beat Soft	4/4	4	100	○		:
DrPc	Rock	4156	MC_8Beat Soft	4/4	4	100	○		:
DrPc	Rock	4157	FA_8Beat Soft	4/4	1	100	○		:
DrPc	Rock	4158	FB_8Beat Soft	4/4	1	100	○		:
DrPc	Rock	4159	FC_8Beat Soft	4/4	1	100	○		:
DrPc	Rock	4160	BA_8Beat Soft	4/4	1	100	○		:
DrPc	Rock	4161	MA_Soft Rock	4/4	4	120	○		"Dry Standard Kit"
DrPc	Rock	4162	MB_Soft Rock	4/4	4	120	○		:
DrPc	Rock	4163	MC_Soft Rock	4/4	4	120	○		:
DrPc	Rock	4164	MD_Soft Rock	4/4	4	120	○		:
DrPc	Rock	4165	IA_Soft Rock	4/4	1	120	○		:
DrPc	Rock	4166	FA_Soft Rock	4/4	1	120	○		:
DrPc	Rock	4167	FB_Soft Rock	4/4	1	120	○		:
DrPc	Rock	4168	FC_Soft Rock	4/4	1	120	○		:
DrPc	Rock	4169	MA_Slowfeel	4/4	1	74	○		"Hyper Standard Kit"
DrPc	Rock	4170	MB_Slowfeel	4/4	1	74	○		:
DrPc	Rock	4171	MC_Slowfeel	4/4	1	74	○		:
DrPc	Rock	4172	MD_Slowfeel	4/4	1	74	○		:
DrPc	Rock	4173	IA_Slowfeel	4/4	2	74	○		:
DrPc	Rock	4174	FA_Slowfeel	4/4	1	74	○		:
DrPc	Rock	4175	FB_Slowfeel	4/4	1	74	○		:
DrPc	Rock	4176	FC_Slowfeel	4/4	2	74	○		:
DrPc	Rock	4177	MA_16Bt Ballad1	4/4	4	75	○		"Power Standard Kit 2"
DrPc	Rock	4178	MB_16Bt Ballad1	4/4	4	75	○		:
DrPc	Rock	4179	MC_16Bt Ballad1	4/4	4	75	○		:
DrPc	Rock	4180	FA_16Bt Ballad1	4/4	1	75	○		:
DrPc	Rock	4181	FB_16Bt Ballad1	4/4	1	75	○		:
DrPc	Rock	4182	FC_16Bt Ballad1	4/4	1	75	○		:
DrPc	Rock	4183	BA_16Bt Ballad1	4/4	1	75	○		:
DrPc	Rock	4184	MA_16Bt Ballad2	4/4	2	64	○		"Power Standard Kit 1"
DrPc	Rock	4185	MB_16Bt Ballad2	4/4	2	64	○		:
DrPc	Rock	4186	MC_16Bt Ballad2	4/4	2	64	○		:
DrPc	Rock	4187	MD_16Bt Ballad2	4/4	2	64	○		:
DrPc	Rock	4188	ME_16Bt Ballad2	4/4	2	64	○		:
DrPc	Rock	4189	MF_16Bt Ballad2	4/4	2	64	○		:
DrPc	Rock	4190	BA_16Bt Ballad2	4/4	1	64	○		:
DrPc	Rock	4191	MA_16BeatBasic1	4/4	4	90	○		:
DrPc	Rock	4192	MB_16BeatBasic1	4/4	4	90	○		:
DrPc	Rock	4193	MC_16BeatBasic1	4/4	4	90	○		:
DrPc	Rock	4194	FA_16BeatBasic1	4/4	1	90	○		:
DrPc	Rock	4195	FB_16BeatBasic1	4/4	1	90	○		:
DrPc	Rock	4196	FC_16BeatBasic1	4/4	1	90	○		:
DrPc	Rock	4197	BA_16BeatBasic1	4/4	1	90	○		:
DrPc	Rock	4198	MA_16BeatBasic2	4/4	4	77	○		:
DrPc	Rock	4199	MB_16BeatBasic2	4/4	4	77	○		:
DrPc	Rock	4200	MC_16BeatBasic2	4/4	4	77	○		:
DrPc	Rock	4201	FA_16BeatBasic2	4/4	1	77	○		:
DrPc	Rock	4202	FB_16BeatBasic2	4/4	1	77	○		:
DrPc	Rock	4203	FC_16BeatBasic2	4/4	1	77	○		:
DrPc	Rock	4204	BA_16BeatBasic2	4/4	1	77	○		:
DrPc	Rock	4205	MA_16Beat Pop 1	4/4	4	103	○		:
DrPc	Rock	4206	MB_16Beat Pop 1	4/4	4	103	○		:
DrPc	Rock	4207	MC_16Beat Pop 1	4/4	4	103	○		:
DrPc	Rock	4208	FA_16Beat Pop 1	4/4	1	103	○		:
DrPc	Rock	4209	FB_16Beat Pop 1	4/4	1	103	○		:
DrPc	Rock	4210	FC_16Beat Pop 1	4/4	1	103	○		:
DrPc	Rock	4211	BA_16Beat Pop 1	4/4	1	103	○		:
DrPc	Rock	4212	MA_16Beat Pop 2	4/4	4	94	○		"Analog T8 Kit"
DrPc	Rock	4213	MB_16Beat Pop 2	4/4	4	94	○		:
DrPc	Rock	4214	MC_16Beat Pop 2	4/4	4	94	○		:
DrPc	Rock	4215	FA_16Beat Pop 2	4/4	1	94	○		:
DrPc	Rock	4216	FB_16Beat Pop 2	4/4	1	94	○		:
DrPc	Rock	4217	FC_16Beat Pop 2	4/4	1	94	○		:
DrPc	Rock	4218	BA_16Beat Pop 2	4/4	1	94	○		:
DrPc	Rock	4219	MA_16Beat Rock	4/4	4	86	○		"Rock Stereo Kit 2"
DrPc	Rock	4220	MB_16Beat Rock	4/4	4	86	○		:
DrPc	Rock	4221	MC_16Beat Rock	4/4	4	86	○		:
DrPc	Rock	4222	FA_16Beat Rock	4/4	1	86	○		:
DrPc	Rock	4223	FB_16Beat Rock	4/4	1	86	○		:
DrPc	Rock	4224	FC_16Beat Rock	4/4	1	86	○		:
DrPc	Rock	4225	BA_16Beat Rock	4/4	1	86	○		:
DrPc	Rock	4226	MA_Piano Club	4/4	2	96	○		"Hyper Standard Kit"
DrPc	Rock	4227	MB_Piano Club	4/4	2	96	○		:

Main Category	Sub Category	ARP No.	ARP Name	Time Signature	Length	Original Tempo	Accent	Random SFX	Voice Type
DrPc	Rock	4228	MC_Piano Club	4/4	2	96	○		"Hyper Standard Kit"
DrPc	Rock	4229	MD_Piano Club	4/4	2	96	○		:
DrPc	Rock	4230	IA_Piano Club/a	4/4	2	96	○		:
DrPc	Rock	4231	IA_Piano Club/b	4/4	2	96	○		:
DrPc	Rock	4232	FA_Piano Club	4/4	1	96	○		:
DrPc	Rock	4233	FB_Piano Club	4/4	1	96	○		:
DrPc	Rock	4234	FC_Piano Club/a	4/4	2	96	○		:
DrPc	Rock	4235	FC_Piano Club/b	4/4	1	96	○		:
DrPc	Rock	4236	MA_Analog Pop	4/4	2	93	○		"Analog T8 Kit"
DrPc	Rock	4237	MB_Analog Pop	4/4	2	93	○		:
DrPc	Rock	4238	MC_Analog Pop	4/4	2	93	○		:
DrPc	Rock	4239	MD_Analog Pop	4/4	4	93	○		:
DrPc	Rock	4240	IA_Analog Pop	4/4	2	93	○		:
DrPc	Rock	4241	FA_Analog Pop	4/4	1	93	○		:
DrPc	Rock	4242	FB_Analog Pop	4/4	1	93	○		:
DrPc	Rock	4243	FC_Analog Pop	4/4	2	93	○		:
DrPc	Rock	4244	MA_ChillKitPop1	4/4	2	85	○		"Chill Out Kit"
DrPc	Rock	4245	MA_ChillKitPop2	4/4	2	85	○		:
DrPc	Rock	4246	MA_ChillKitPop3	4/4	2	85	○		:
DrPc	Rock	4247	MA_ChillKitPop4	4/4	2	85	○		:
DrPc	Rock	4248	MA_ChillKitPop5	4/4	2	85	○		:
DrPc	Rock	4249	MA_ChillKitBallad1	4/4	2	90	○		:
DrPc	Rock	4250	MB_ChillKitBallad1	4/4	2	90	○		:
DrPc	Rock	4251	MA_ChillKitBallad2	4/4	2	90	○		:
DrPc	Rock	4252	MB_ChillKitBallad2	4/4	2	90	○		:
DrPc	Rock	4253	MA_ChillKitBallad3	4/4	2	90	○		:
DrPc	Rock	4254	MA_ChillKitBallad4	4/4	2	90	○		:
DrPc	Rock	4255	MA_ChillKitBallad5	4/4	2	90	○		:
DrPc	Rock	4256	MA_6/8 Pop	4/4	4	100	○		"Power Standard Kit 1"
DrPc	Rock	4257	MB_6/8 Pop	4/4	4	100	○		:
DrPc	Rock	4258	MC_6/8 Pop	4/4	4	100	○		:
DrPc	Rock	4259	FA_6/8 Pop	4/4	1	100	○		:
DrPc	Rock	4260	FB_6/8 Pop	4/4	1	100	○		:
DrPc	Rock	4261	FC_6/8 Pop	4/4	1	100	○		:
DrPc	Rock	4262	BA_6/8 Pop	4/4	1	100	○		:
DrPc	Rock	4263	MA_6/8 Ballad	6/8	4	87	○		"Power Standard Kit 2"
DrPc	Rock	4264	MB_6/8 Ballad	6/8	4	87	○		:
DrPc	Rock	4265	MC_6/8 Ballad	6/8	4	87	○		:
DrPc	Rock	4266	FA_6/8 Ballad	6/8	1	87	○		:
DrPc	Rock	4267	FB_6/8 Ballad	6/8	1	87	○		:
DrPc	Rock	4268	FC_6/8 Ballad	6/8	1	87	○		:
DrPc	Rock	4269	BA_6/8 Ballad	6/8	1	87	○		:
DrPc	Rock	4270	MA_ProgresRock1	4/4	4	110	○		"Modern Rock Kit"
DrPc	Rock	4271	MB_ProgresRock1	4/4	3	110	○		:
DrPc	Rock	4272	MC_ProgresRock1	4/4	4	110	○		:
DrPc	Rock	4273	FA_ProgresRock1	4/4	1	110	○		:
DrPc	Rock	4274	FB_ProgresRock1	4/4	1	110	○		:
DrPc	Rock	4275	FC_ProgresRock1	4/4	1	110	○		:
DrPc	Rock	4276	BA_ProgresRock1	4/4	1	110	○		:
DrPc	Rock	4277	MA_ProgresRock2	4/4	4	120	○		"Power Standard Kit 2"
DrPc	Rock	4278	MB_ProgresRock2	4/4	4	120	○		:
DrPc	Rock	4279	MC_ProgresRock2	4/4	4	120	○		:
DrPc	Rock	4280	FA_ProgresRock2	4/4	1	120	○		:
DrPc	Rock	4281	FB_ProgresRock2	4/4	1	120	○		:
DrPc	Rock	4282	FC_ProgresRock2	4/4	1	120	○		:
DrPc	Rock	4283	BA_ProgresRock2	4/4	1	120	○		:
DrPc	R&B	4284	MA_Funk 1	4/4	8	104	○		"Power Standard Kit 1"
DrPc	R&B	4285	MB_Funk 1	4/4	8	104	○		:
DrPc	R&B	4286	MC_Funk 1	4/4	8	104	○		:
DrPc	R&B	4287	FA_Funk 1	4/4	1	104	○		:
DrPc	R&B	4288	FB_Funk 1	4/4	1	104	○		:
DrPc	R&B	4289	FC_Funk 1	4/4	1	104	○		:
DrPc	R&B	4290	BA_Funk 1	4/4	1	104	○		:
DrPc	R&B	4291	MA_Funk 2 /1	4/4	4	107	○		"Hyper Standard Kit"
DrPc	R&B	4292	MB_Funk 2 /1	4/4	4	107	○		:
DrPc	R&B	4293	MC_Funk 2	4/4	4	107	○		:
DrPc	R&B	4294	MD_Funk 2	4/4	4	107	○		:
DrPc	R&B	4295	IA_Funk 2	4/4	4	107	○		:
DrPc	R&B	4296	FA_Funk 2	4/4	1	107	○		:
DrPc	R&B	4297	FB_Funk 2 /1	4/4	1	107	○		:
DrPc	R&B	4298	FC_Funk 2 /1	4/4	1	107	○		:
DrPc	R&B	4299	MA_Funk 2 /2	4/4	2	107	○		:
DrPc	R&B	4300	MB_Funk 2 /2	4/4	4	107	○		:
DrPc	R&B	4301	FB_Funk 2 /2	4/4	1	107	○		:
DrPc	R&B	4302	FC_Funk 2 /2	4/4	1	107	○		:
DrPc	R&B	4303	MA_Funk 3	4/4	2	132	○		"Dry Standard Kit"
DrPc	R&B	4304	MB_Funk 3	4/4	2	132	○		:
DrPc	R&B	4305							

Arpeggio Type List

Main Category	Sub Category	ARP No.	ARP Name	Time Signature	Length	Original Tempo	Accent	Random SFX	Voice Type
DrPc	R&B	4311	MA_Funk 4	4/4	2	110	○		"Dry Standard Kit"
DrPc	R&B	4312	MB_Funk 4	4/4	2	110	○		:
DrPc	R&B	4313	MC_Funk 4	4/4	4	110	○		:
DrPc	R&B	4314	MD_Funk 4	4/4	4	110	○		:
DrPc	R&B	4315	MA_Cool Funk	4/4	2	96	○		"Hyper Standard Kit"
DrPc	R&B	4316	MB_Cool Funk	4/4	2	96	○		:
DrPc	R&B	4317	MC_Cool Funk	4/4	2	96	○		:
DrPc	R&B	4318	MD_Cool Funk	4/4	2	96	○		:
DrPc	R&B	4319	IA_Cool Funk	4/4	2	96	○		:
DrPc	R&B	4320	FA_Cool Funk	4/4	1	96	○		:
DrPc	R&B	4321	FB_Cool Funk	4/4	1	96	○		:
DrPc	R&B	4322	FC_Cool Funk	4/4	2	96	○		:
DrPc	R&B	4323	MA_Funk PopRock	4/4	4	95	○		"Power Standard Kit 1"
DrPc	R&B	4324	MB_Funk PopRock	4/4	4	95	○		:
DrPc	R&B	4325	MC_Funk PopRock	4/4	4	95	○		:
DrPc	R&B	4326	FA_Funk PopRock	4/4	1	95	○		:
DrPc	R&B	4327	FB_Funk PopRock	4/4	1	95	○		:
DrPc	R&B	4328	FC_Funk PopRock	4/4	1	95	○		:
DrPc	R&B	4329	BA_Funk PopRock	4/4	1	95	○		:
DrPc	R&B	4330	MA_Jazz Funk 1	4/4	4	120	○		:
DrPc	R&B	4331	MB_Jazz Funk 1	4/4	4	120	○		:
DrPc	R&B	4332	MC_Jazz Funk 1	4/4	4	120	○		:
DrPc	R&B	4333	FA_Jazz Funk 1	4/4	1	120	○		:
DrPc	R&B	4334	FB_Jazz Funk 1	4/4	1	120	○		:
DrPc	R&B	4335	FC_Jazz Funk 1	4/4	1	120	○		:
DrPc	R&B	4336	BA_Jazz Funk 1	4/4	1	120	○		:
DrPc	R&B	4337	MA_Jazz Funk 2	4/4	4	120	○		"Dry Standard Kit"
DrPc	R&B	4338	MB_Jazz Funk 2	4/4	4	120	○		:
DrPc	R&B	4339	MC_Jazz Funk 2	4/4	4	120	○		:
DrPc	R&B	4340	MD_Jazz Funk 2	4/4	4	120	○		:
DrPc	R&B	4341	IA_Jazz Funk 2	4/4	2	120	○		:
DrPc	R&B	4342	FA_Jazz Funk 2	4/4	1	120	○		:
DrPc	R&B	4343	FB_Jazz Funk 2	4/4	1	120	○		:
DrPc	R&B	4344	FC_Jazz Funk 2	4/4	1	120	○		:
DrPc	R&B	4345	MA1_Jazz Funk 3	4/4	4	123	○		"Hip Hop Kit 1"
DrPc	R&B	4346	MB1_Jazz Funk 3	4/4	4	123	○		:
DrPc	R&B	4347	MC1_Jazz Funk 3	4/4	4	123	○		:
DrPc	R&B	4348	MD1_Jazz Funk 3	4/4	2	123	○		:
DrPc	R&B	4349	FA1_Jazz Funk 3	4/4	1	123	○		:
DrPc	R&B	4350	FB1_Jazz Funk 3	4/4	1	123	○		:
DrPc	R&B	4351	FC1_Jazz Funk 3	4/4	1	123	○		:
DrPc	R&B	4352	FD1_Jazz Funk 3	4/4	1	123	○		:
DrPc	R&B	4353	MA2_Jazz Funk 3	4/4	4	123	○		"Latin Percussion Kit"
DrPc	R&B	4354	MB2_Jazz Funk 3	4/4	4	123	○		:
DrPc	R&B	4355	MC2_Jazz Funk 3	4/4	4	123	○		:
DrPc	R&B	4356	MD2_Jazz Funk 3	4/4	2	123	○		:
DrPc	R&B	4357	FA2_Jazz Funk 3	4/4	1	123	○		:
DrPc	R&B	4358	FB2_Jazz Funk 3	4/4	1	123	○		:
DrPc	R&B	4359	FC2_Jazz Funk 3	4/4	1	123	○		:
DrPc	R&B	4360	FD2_Jazz Funk 3	4/4	1	123	○		:
DrPc	R&B	4361	MA_Jazz Pop	4/4	2	102	○		"Power Standard Kit 1"
DrPc	R&B	4362	MB_Jazz Pop	4/4	2	102	○		:
DrPc	R&B	4363	MC_Jazz Pop	4/4	2	102	○		:
DrPc	R&B	4364	FA_Jazz Pop	4/4	1	102	○		:
DrPc	R&B	4365	FB_Jazz Pop	4/4	1	102	○		:
DrPc	R&B	4366	FC_Jazz Pop	4/4	1	102	○		:
DrPc	R&B	4367	BA_Jazz Pop	4/4	1	102	○		:
DrPc	R&B	4368	MA_Slow & Easy	4/4	4	72	○		:
DrPc	R&B	4369	MB_Slow & Easy	4/4	4	72	○		:
DrPc	R&B	4370	MC_Slow & Easy	4/4	4	72	○		:
DrPc	R&B	4371	FA_Slow & Easy	4/4	1	72	○		:
DrPc	R&B	4372	FB_Slow & Easy	4/4	1	72	○		:
DrPc	R&B	4373	FC_Slow & Easy	4/4	1	72	○		:
DrPc	R&B	4374	BA_Slow & Easy	4/4	1	72	○		:
DrPc	R&B	4375	MA_Club Jazz 1	4/4	4	125	○		:
DrPc	R&B	4376	MB_Club Jazz 1	4/4	4	125	○		:
DrPc	R&B	4377	MC_Club Jazz 1	4/4	4	125	○		:
DrPc	R&B	4378	FA_Club Jazz 1	4/4	1	125	○		:
DrPc	R&B	4379	FB_Club Jazz 1	4/4	1	125	○		:
DrPc	R&B	4380	FC_Club Jazz 1	4/4	1	125	○		:
DrPc	R&B	4381	BA_Club Jazz 1	4/4	1	125	○		:
DrPc	R&B	4382	MA_Club Jazz 2	4/4	4	92	○		:
DrPc	R&B	4383	MB_Club Jazz 2	4/4	4	92	○		:
DrPc	R&B	4384	MC_Club Jazz 2	4/4	4	92	○		:
DrPc	R&B	4385	FA_Club Jazz 2	4/4	1	92	○		:
DrPc	R&B	4386	FB_Club Jazz 2	4/4	1	92	○		:
DrPc	R&B	4387	FC_Club Jazz 2	4/4	1	92	○		:
DrPc	R&B	4388	BA_Club Jazz 2	4/4	1	92	○		:
DrPc	R&B	4389	MA_Pop Shuffle1	4/4	4	94	○		:
DrPc	R&B	4390	MB_Pop Shuffle1	4/4	4	94	○		:
DrPc	R&B	4391	MC_Pop Shuffle1	4/4	4	94	○		:
DrPc	R&B	4392	FA_Pop Shuffle1	4/4	1	94	○		:
DrPc	R&B	4393	FB_Pop Shuffle1	4/4	1	94	○		:

Main Category	Sub Category	ARP No.	ARP Name	Time Signature	Length	Original Tempo	Accent	Random SFX	Voice Type
DrPc	R&B	4394	FC_Pop Shuffle1	4/4	1	94	○		"Power Standard Kit 1"
DrPc	R&B	4395	BA_Pop Shuffle1	4/4	1	94	○		:
DrPc	R&B	4396	MA_Pop Shuffle2	4/4	4	80	○		"R&B Kit 3"
DrPc	R&B	4397	MB_Pop Shuffle2	4/4	4	80	○		:
DrPc	R&B	4398	MC_Pop Shuffle2	4/4	4	80	○		:
DrPc	R&B	4399	FA_Pop Shuffle2	4/4	1	80	○		:
DrPc	R&B	4400	FB_Pop Shuffle2	4/4	1	80	○		:
DrPc	R&B	4401	FC_Pop Shuffle2	4/4	1	80	○		:
DrPc	R&B	4402	BA_Pop Shuffle2	4/4	1	80	○		:
DrPc	R&B	4403	MA_Gospel Funk	4/4	4	106	○		"Power Standard Kit 1"
DrPc	R&B	4404	MB_Gospel Funk	4/4	4	106	○		:
DrPc	R&B	4405	MC_Gospel Funk	4/4	4	106	○		:
DrPc	R&B	4406	FA_Gospel Funk	4/4	1	106	○		:
DrPc	R&B	4407	FB_Gospel Funk	4/4	1	106	○		:
DrPc	R&B	4408	FC_Gospel Funk	4/4	1	106	○		:
DrPc	R&B	4409	BA_Gospel Funk	4/4	1	106	○		:
DrPc	R&B	4410	MA_Funk Disco	4/4	2	126	○		"Power Standard Kit 2"
DrPc	R&B	4411	MB_Funk Disco	4/4	2	126	○		:
DrPc	R&B	4412	MC_Funk Disco	4/4	2	126	○		:
DrPc	R&B	4413	FA_Funk Disco	4/4	1	126	○		:
DrPc	R&B	4414	FB_Funk Disco	4/4	1	126	○		:
DrPc	R&B	4415	FC_Funk Disco	4/4	1	126	○		:
DrPc	R&B	4416	BA_Funk Disco	4/4	1	126	○		:
DrPc	R&B	4417	MA1_StandrdDisco	4/4	4	120	○		:
DrPc	R&B	4418	MB1_StandrdDisco	4/4	4	120	○		:
DrPc	R&B	4419	MC1_StandrdDisco	4/4	4	120	○		:
DrPc	R&B	4420	FA1_StandrdDisco	4/4	1	120	○		:
DrPc	R&B	4421	FB1_StandrdDisco	4/4	1	120	○		:
DrPc	R&B	4422	FC1_StandrdDisco	4/4	1	120	○		:
DrPc	R&B	4423	BA1_StandrdDisco	4/4	1	120	○		:
DrPc	R&B	4424	MA2_StandrdDisco	4/4	4	120	○		"Pop Latin Kit"
DrPc	R&B	4425	MB2_StandrdDisco	4/4	4	120	○		:
DrPc	R&B	4426	MC2_StandrdDisco	4/4	4	120	○		:
DrPc	R&B	4427	FA2_StandrdDisco	4/4	1	120	○		:
DrPc	R&B	4428	FB2_StandrdDisco	4/4	1	120	○		:
DrPc	R&B	4429	FC2_StandrdDisco	4/4	1	120	○		:
DrPc	R&B	4430	BA2_StandrdDisco	4/4	1	120	○		:
DrPc	R&B	4431	MA1_Retro Disco	4/4	4	108	○		"Power Standard Kit 1"
DrPc	R&B	4432	MB1_Retro Disco	4/4	4	108	○		:
DrPc	R&B	4433	MC1_Retro Disco	4/4	4	108	○		:
DrPc	R&B	4434	FA1_Retro Disco	4/4	1	108	○		:
DrPc	R&B	4435	FB1_Retro Disco	4/4	1	108	○		:
DrPc	R&B	4436	FC1_Retro Disco	4/4	1	108	○		:
DrPc	R&B	4437	BA1_Retro Disco	4/4	1	108	○		:
DrPc	R&B	4438	MA2_Retro Disco	4/4	4	108	○		"Pop Latin Kit"
DrPc	R&B	4439	MB2_Retro Disco	4/4	4	108	○		:
DrPc	R&B	4440	MC2_Retro Disco	4/4	4	108	○		:
DrPc	R&B	4441	FA2_Retro Disco	4/4	1	108	○		:
DrPc	R&B	4442	FB2_Retro Disco	4/4	1	108	○		:
DrPc	R&B	4443	FC2_Retro Disco	4/4	1	108	○		:
DrPc	R&B	4444	BA2_Retro Disco	4/4	1	108	○		:
DrPc	R&B	4445	MA1_70sCoolDisco	4/4	4	114	○		"Power Standard Kit 1"
DrPc	R&B	4446	MB1_70sCoolDisco	4/4	4	114	○		:
DrPc	R&B	4447	MC1_70sCoolDisco	4/4	4	114	○		:
DrPc	R&B	4448	FA1_70sCoolDisco	4/4	1	114	○		:
DrPc	R&B	4449	FB1_70sCoolDisco	4/4	1	114	○		:
DrPc	R&B	4450	FC1_70sCoolDisco	4/4	1	114	○		:
DrPc	R&B	4451	BA1_70sCoolDisco	4/4	1	114	○		:
DrPc	R&B	4452	MA2_70sCoolDisco	4/4	4	114	○		"Pop Latin Kit"
DrPc	R&B	4453	MB2_70sCoolDisco	4/4	4	114	○		:
DrPc	R&B	4454	MC2_70sCoolDisco	4/4	4	114	○		:
DrPc	R&B	4455	FA2_70sCoolDisco	4/4	1	114	○		:
DrPc	R&B	4456	FB2_70sCoolDisco	4/4	1	114	○		:
DrPc	R&B	4457	FC2_70sCoolDisco	4/4	1	114	○		:
DrPc	R&B	4458	BA2_70sCoolDisco	4/4	1	114	○		:
DrPc	R&B	4459	MA_70sDiscoFunk	4/4	4	112	○		"Power Standard Kit 1"
DrPc	R&B	4460	MB_70sDiscoFunk	4/4	4	112	○		:
DrPc	R&B	4461	MC_70sDiscoFunk	4/4	4	112	○		:
DrPc	R&B	4462	FA_70sDiscoFunk	4/4	1	112	○		:
DrPc	R&B	4463	FB_70sDiscoFunk	4/4	1	112	○		:
DrPc	R&B	4464	FC_70sDiscoFunk	4/4	1	112	○		:
DrPc	R&B	4465	BA_70sDiscoFunk	4/4	1	112	○		:
DrPc	R&B	4466	MA_Philadelphia	4/4	2	100	○		:
DrPc	R&B								

Main Category	Sub Category	ARP No.	ARP Name	Time Signature	Length	Original Tempo	Accent	Random SFX	Voice Type
DrPc	R&B	4477	IA_R&B Disco	4/4	1	110	○		"Dry Standard Kit"
DrPc	R&B	4478	FA_R&B Disco	4/4	1	110	○		:
DrPc	R&B	4479	FB_R&B Disco	4/4	1	110	○		:
DrPc	R&B	4480	FC_R&B Disco	4/4	2	110	○		:
DrPc	R&B	4481	MA_Chart R&B	4/4	4	130	○		"R&B Kit 1"
DrPc	R&B	4482	MB_Chart R&B	4/4	4	130	○		:
DrPc	R&B	4483	MC_Chart R&B	4/4	4	130	○		:
DrPc	R&B	4484	FA_Chart R&B	4/4	1	130	○		:
DrPc	R&B	4485	FB_Chart R&B	4/4	1	130	○		:
DrPc	R&B	4486	FC_Chart R&B	4/4	1	130	○		:
DrPc	R&B	4487	BA_Chart R&B	4/4	1	130	○		:
DrPc	R&B	4488	MA1_ChartPop1	4/4	4	92	○		"Hip Hop Kit 3"
DrPc	R&B	4489	MB1_ChartPop1	4/4	4	92	○		:
DrPc	R&B	4490	MC1_ChartPop1	4/4	4	92	○		:
DrPc	R&B	4491	FA1_ChartPop1	4/4	1	92	○		:
DrPc	R&B	4492	FB1_ChartPop1	4/4	1	92	○		:
DrPc	R&B	4493	FC1_ChartPop1	4/4	1	92	○		:
DrPc	R&B	4494	BA1_ChartPop1	4/4	1	92	○		:
DrPc	R&B	4495	MA2_ChartPop1	4/4	4	92	○		"Power Standard Kit 2"
DrPc	R&B	4496	MB2_ChartPop1	4/4	4	92	○		:
DrPc	R&B	4497	MC2_ChartPop1	4/4	4	92	○		:
DrPc	R&B	4498	FA2_ChartPop1	4/4	1	92	○		:
DrPc	R&B	4499	FB2_ChartPop1	4/4	1	92	○		:
DrPc	R&B	4500	FC2_ChartPop1	4/4	1	92	○		:
DrPc	R&B	4501	BA2_ChartPop1	4/4	1	92	○		:
DrPc	R&B	4502	MA1_ChartPop2	4/4	2	92	○		"Hip Hop Kit 3"
DrPc	R&B	4503	MB1_ChartPop2	4/4	2	92	○		:
DrPc	R&B	4504	MC1_ChartPop2	4/4	2	92	○		:
DrPc	R&B	4505	MD1_ChartPop2	4/4	2	92	○		:
DrPc	R&B	4506	FA1_ChartPop2	4/4	1	92	○		:
DrPc	R&B	4507	FC1_ChartPop2	4/4	1	92	○		:
DrPc	R&B	4508	FD1_ChartPop2	4/4	1	92	○		:
DrPc	R&B	4509	MA2_ChartPop2	4/4	2	92	○		"Hip Hop Kit 1"
DrPc	R&B	4510	MB2_ChartPop2	4/4	2	92	○		:
DrPc	R&B	4511	MC2_ChartPop2	4/4	2	92	○		:
DrPc	R&B	4512	MD2_ChartPop2	4/4	2	92	○		:
DrPc	R&B	4513	FA2_ChartPop2	4/4	1	92	○		:
DrPc	R&B	4514	FB2_ChartPop2	4/4	1	92	○		:
DrPc	R&B	4515	FC2_ChartPop2	4/4	1	92	○		:
DrPc	R&B	4516	FD2_ChartPop2	4/4	1	92	○		:
DrPc	R&B	4517	MA1_R&B	4/4	2	83	○		"Power Standard Kit 1"
DrPc	R&B	4518	MB1_R&B	4/4	2	83	○		:
DrPc	R&B	4519	MC1_R&B	4/4	2	83	○		:
DrPc	R&B	4520	FA1_R&B	4/4	1	83	○		:
DrPc	R&B	4521	FB1_R&B	4/4	1	83	○		:
DrPc	R&B	4522	FC1_R&B	4/4	1	83	○		:
DrPc	R&B	4523	BA1_R&B	4/4	1	83	○		:
DrPc	R&B	4524	MA2_R&B	4/4	2	83	○		"R&B Kit 1"
DrPc	R&B	4525	MB2_R&B	4/4	2	83	○		:
DrPc	R&B	4526	MC2_R&B	4/4	2	83	○		:
DrPc	R&B	4527	FA2_R&B	4/4	1	83	○		:
DrPc	R&B	4528	FB2_R&B	4/4	1	83	○		:
DrPc	R&B	4529	FC2_R&B	4/4	1	83	○		:
DrPc	R&B	4530	BA2_R&B	4/4	1	83	○		:
DrPc	R&B	4531	MA1_New R&B 1	4/4	2	98	○		"Power Standard Kit 1"
DrPc	R&B	4532	MB1_New R&B 1	4/4	2	98	○		:
DrPc	R&B	4533	MC1_New R&B 1	4/4	2	98	○		:
DrPc	R&B	4534	FA1_New R&B 1	4/4	1	98	○		:
DrPc	R&B	4535	FB1_New R&B 1	4/4	1	98	○		:
DrPc	R&B	4536	FC1_New R&B 1	4/4	1	98	○		:
DrPc	R&B	4537	BA1_New R&B 1	4/4	1	98	○		:
DrPc	R&B	4538	MA2_New R&B 1	4/4	2	98	○		"R&B Kit 2"
DrPc	R&B	4539	MB2_New R&B 1	4/4	2	98	○		:
DrPc	R&B	4540	MC2_New R&B 1	4/4	2	98	○		:
DrPc	R&B	4541	FA2_New R&B 1	4/4	1	98	○		:
DrPc	R&B	4542	FB2_New R&B 1	4/4	1	98	○		:
DrPc	R&B	4543	FC2_New R&B 1	4/4	1	98	○		:
DrPc	R&B	4544	BA2_New R&B 1	4/4	1	98	○		:
DrPc	R&B	4545	MA1_New R&B 2	4/4	1	97	○		"Hip Hop Kit 3"
DrPc	R&B	4546	MB1_New R&B 2	4/4	1	97	○		:
DrPc	R&B	4547	MC1_New R&B 2	4/4	1	97	○		:
DrPc	R&B	4548	MD1_New R&B 2	4/4	1	97	○		:
DrPc	R&B	4549	IA1_New R&B 2	4/4	2	97	○		:
DrPc	R&B	4550	FA1_New R&B 2	4/4	1	97	○		:
DrPc	R&B	4551	FB1_New R&B 2	4/4	1	97	○		:
DrPc	R&B	4552	FC1_New R&B 2	4/4	2	97	○		:
DrPc	R&B	4553	MA2_New R&B 3	4/4	2	90	○		:
DrPc	R&B	4554	MB2_New R&B 3	4/4	2	90	○		:
DrPc	R&B	4555	MC2_New R&B 3	4/4	2	90	○		:
DrPc	R&B	4556	MD2_New R&B 3	4/4	2	90	○		:
DrPc	R&B	4557	IA2_New R&B 3	4/4	2	90	○		:
DrPc	R&B	4558	FA2_New R&B 3	4/4	1	90	○		:
DrPc	R&B	4559	FB2_New R&B 3	4/4	1	90	○		:

Main Category	Sub Category	ARP No.	ARP Name	Time Signature	Length	Original Tempo	Accent	Random SFX	Voice Type
DrPc	R&B	4560	FC2_New R&B 3	4/4	2	90	○		"Hip Hop Kit 3"
DrPc	R&B	4561	MA_Pop R&B	4/4	4	67	○		"Hip Hop Kit 1"
DrPc	R&B	4562	MB_Pop R&B	4/4	4	67	○		:
DrPc	R&B	4563	MC_Pop R&B	4/4	4	67	○		:
DrPc	R&B	4564	FA_Pop R&B	4/4	1	67	○		:
DrPc	R&B	4565	FB_Pop R&B	4/4	1	67	○		:
DrPc	R&B	4566	FC_Pop R&B	4/4	1	67	○		:
DrPc	R&B	4567	BA_Pop R&B	4/4	1	67	○		:
DrPc	R&B	4568	MA_H-R&B Pop	4/4	4	140	○		"R&B Kit 1"
DrPc	R&B	4569	MB_H-R&B Pop	4/4	4	140	○		:
DrPc	R&B	4570	MC_H-R&B Pop	4/4	4	140	○		:
DrPc	R&B	4571	FA_H-R&B Pop	4/4	1	140	○		:
DrPc	R&B	4572	FB_H-R&B Pop	4/4	1	140	○		:
DrPc	R&B	4573	FC_H-R&B Pop	4/4	1	140	○		:
DrPc	R&B	4574	BA_H-R&B Pop	4/4	1	140	○		:
DrPc	R&B	4575	MA_J-R&B Pop	4/4	4	100	○		"Hip Hop Kit 4"
DrPc	R&B	4576	MB_J-R&B Pop	4/4	4	100	○		:
DrPc	R&B	4577	MC_J-R&B Pop	4/4	4	100	○		:
DrPc	R&B	4578	FA_J-R&B Pop	4/4	1	100	○		:
DrPc	R&B	4579	FB_J-R&B Pop	4/4	1	100	○		:
DrPc	R&B	4580	FC_J-R&B Pop	4/4	1	100	○		:
DrPc	R&B	4581	BA_J-R&B Pop	4/4	1	100	○		:
DrPc	R&B	4582	MA_R&B Ana Pop	4/4	4	95	○		"Hip Hop Kit 1"
DrPc	R&B	4583	MB_R&B Ana Pop	4/4	4	95	○		:
DrPc	R&B	4584	MC_R&B Ana Pop	4/4	4	95	○		:
DrPc	R&B	4585	FA_R&B Ana Pop	4/4	1	95	○		:
DrPc	R&B	4586	FB_R&B Ana Pop	4/4	1	95	○		:
DrPc	R&B	4587	FC_R&B Ana Pop	4/4	1	95	○		:
DrPc	R&B	4588	BA_R&B Ana Pop	4/4	1	95	○		:
DrPc	R&B	4589	MA_R&B Ballad 1	4/4	4	70	○		"Hip Hop Kit 4"
DrPc	R&B	4590	MB_R&B Ballad 1	4/4	4	70	○		:
DrPc	R&B	4591	MC_R&B Ballad 1	4/4	4	70	○		:
DrPc	R&B	4592	FA_R&B Ballad 1	4/4	1	70	○		:
DrPc	R&B	4593	FB_R&B Ballad 1	4/4	1	70	○		:
DrPc	R&B	4594	FC_R&B Ballad 1	4/4	1	70	○		:
DrPc	R&B	4595	BA_R&B Ballad 1	4/4	1	70	○		:
DrPc	R&B	4596	MA1_R&B Ballad 2	4/4	2	60	○		"Hip Hop Kit 2"
DrPc	R&B	4597	MB1_R&B Ballad 2	4/4	2	60	○		:
DrPc	R&B	4598	MC1_R&B Ballad 2	4/4	2	60	○		:
DrPc	R&B	4599	MD1_R&B Ballad 2	4/4	2	60	○		:
DrPc	R&B	4600	FA1_R&B Ballad 2	4/4	1	60	○		:
DrPc	R&B	4601	FB1_R&B Ballad 2	4/4	1	60	○		:
DrPc	R&B	4602	FC1_R&B Ballad 2	4/4	1	60	○		:
DrPc	R&B	4603	FA2_R&B Ballad 2	4/4	1	60	○		:
DrPc	R&B	4604	MA2_R&B Ballad 2	4/4	2	60	○		"Hip Hop Kit 1"
DrPc	R&B	4605	MB2_R&B Ballad 2	4/4	2	60	○		:
DrPc	R&B	4606	MC2_R&B Ballad 2	4/4	2	60	○		:
DrPc	R&B	4607	MD2_R&B Ballad 2	4/4	2	60	○		:
DrPc	R&B	4608	FA2_R&B Ballad 2	4/4	1	60	○		:
DrPc	R&B	4609	FB2_R&B Ballad 2	4/4	1	60	○		:
DrPc	R&B	4610	FC2_R&B Ballad 2	4/4	1	60	○		:
DrPc	R&B	4611	FD2_R&B Ballad 2	4/4	1	60	○		:
DrPc	R&B	4612	MA_R&B Ballad 3	4/4	4	113	○		"R&B Kit 2"
DrPc	R&B	4613	MB_R&B Ballad 3	4/4	4	113	○		:
DrPc	R&B	4614	MC_R&B Ballad 3	4/4	4	113	○		:
DrPc	R&B	4615	FA_R&B Ballad 3	4/4	1	113	○		:
DrPc	R&B	4616	FB_R&B Ballad 3	4/4	1	113	○		:
DrPc	R&B	4617	FC_R&B Ballad 3	4/4	1	113	○		:
DrPc	R&B	4618	BA_R&B Ballad 3	4/4	1	113	○		:
DrPc	R&B	4619	MA_6/8 R&B	4/4	2	61	○		"Hip Hop Kit 3"
DrPc	R&B	4620	MB_6/8 R&B	4/4	2	61	○		:
DrPc	R&B	4621	MC_6/8 R&B	4/4	2	61	○		:
DrPc	R&B	4622	MD_6/8 R&B	4/4	2	61	○		:
DrPc	R&B	4623	IA_6/8 R&B	4/4	2	61	○		:
DrPc	R&B	4624	FA_6/8 R&B	4/4	1	61	○		:
DrPc	R&B	4625	FB_6/8 R&B	4/4	1	61	○		:
DrPc	R&B	4626	FC_6/8 R&B	4/4	2	61	○		:
DrPc	R&B	4627	MA_Smooth 1	4/4	2	115	○		:
DrPc	R&B	4628	MB_Smooth 1	4/4	2	115	○		:
DrPc	R&B	4629	MC_Smooth 1	4/4	2	115	○		:
DrPc	R&B	4630							

Arpeggio Type List

Main Category	Sub Category	ARP No.	ARP Name	Time Signature	Length	Original Tempo	Accent	Random SFX	Voice Type
DrPc	R&B	4643	IA_Flip Hop 1	4/4	2	132	○		"Hip Hop Kit 3"
DrPc	R&B	4644	FA_Flip Hop 1	4/4	1	132	○		:
DrPc	R&B	4645	FB_Flip Hop 1	4/4	1	132	○		:
DrPc	R&B	4646	FC_Flip Hop 1	4/4	4	132	○		:
DrPc	R&B	4647	MA_Flip Hop 2	4/4	4	125	○		:
DrPc	R&B	4648	MB_Flip Hop 2	4/4	4	125	○		:
DrPc	R&B	4649	MC_Flip Hop 2	4/4	4	125	○		:
DrPc	R&B	4650	MD_Flip Hop 2	4/4	4	125	○		:
DrPc	R&B	4651	MA_2BZ4U	4/4	4	75	○		"Nu Hip Hop Kit 2"
DrPc	R&B	4652	MB_2BZ4U	4/4	4	75	○		:
DrPc	R&B	4653	MC_2BZ4U	4/4	4	75	○		:
DrPc	R&B	4654	MD_2BZ4U	4/4	4	75	○		:
DrPc	R&B	4655	MA_Bklyn	4/4	4	89	○		"Hip Hop Kit 1"
DrPc	R&B	4656	MB_Bklyn	4/4	4	89	○		:
DrPc	R&B	4657	MC_Bklyn	4/4	4	89	○		:
DrPc	R&B	4658	MD_Bklyn	4/4	4	89	○		:
DrPc	R&B	4659	ME_Bklyn	4/4	4	89	○		:
DrPc	R&B	4660	MF_Bklyn	4/4	4	89	○		:
DrPc	R&B	4661	MA_DirtySynth	4/4	4	85	○		"Analog T8 Kit"
DrPc	R&B	4662	MB_DirtySynth	4/4	4	85	○		:
DrPc	R&B	4663	MC_DirtySynth	4/4	4	85	○		:
DrPc	R&B	4664	MA_PepRally	4/4	2	75	○		"Nu Hip Hop Kit 1"
DrPc	R&B	4665	MB_PepRally	4/4	2	75	○		:
DrPc	R&B	4666	MC_PepRally	4/4	2	75	○		:
DrPc	R&B	4667	MD_PepRally	4/4	2	75	○		:
DrPc	R&B	4668	ME_PepRally	4/4	2	75	○		:
DrPc	R&B	4669	MA_HipHopEpic/1	4/4	2	85	○		"Hip Hop Kit 4"
DrPc	R&B	4670	MA_HipHopEpic/2	4/4	2	85	○		:
DrPc	R&B	4671	MA_HipHopEpic/3	4/4	2	85	○		:
DrPc	R&B	4672	MB_HipHopEpic/1	4/4	2	85	○		:
DrPc	R&B	4673	MB_HipHopEpic/2	4/4	2	85	○		:
DrPc	R&B	4674	MB_HipHopEpic/3	4/4	2	85	○		:
DrPc	R&B	4675	MC_HipHopEpic/1	4/4	2	85	○		:
DrPc	R&B	4676	MC_HipHopEpic/2	4/4	2	85	○		:
DrPc	R&B	4677	MC_HipHopEpic/3	4/4	2	85	○		:
DrPc	R&B	4678	MA1_New Hip Hop	4/4	2	85	○		"Power Standard Kit 1"
DrPc	R&B	4679	MB1_New Hip Hop	4/4	2	85	○		:
DrPc	R&B	4680	MC1_New Hip Hop	4/4	2	85	○		:
DrPc	R&B	4681	FA1_New Hip Hop	4/4	1	85	○		:
DrPc	R&B	4682	FB1_New Hip Hop	4/4	1	85	○		:
DrPc	R&B	4683	FC1_New Hip Hop	4/4	1	85	○		:
DrPc	R&B	4684	BA1_New Hip Hop	4/4	1	85	○		:
DrPc	R&B	4685	MA2_New Hip Hop	4/4	2	85	○		"Hip Hop Kit 2"
DrPc	R&B	4686	MB2_New Hip Hop	4/4	2	85	○		:
DrPc	R&B	4687	MC2_New Hip Hop	4/4	2	85	○		:
DrPc	R&B	4688	FA2_New Hip Hop	4/4	1	85	○		:
DrPc	R&B	4689	FB2_New Hip Hop	4/4	1	85	○		:
DrPc	R&B	4690	FC2_New Hip Hop	4/4	1	85	○		:
DrPc	R&B	4691	BA2_New Hip Hop	4/4	1	85	○		:
DrPc	R&B	4692	MA_East Coast	4/4	2	103	○		"Hip Hop Kit 1"
DrPc	R&B	4693	MB_East Coast	4/4	2	103	○		:
DrPc	R&B	4694	MC_East Coast	4/4	2	103	○		:
DrPc	R&B	4695	MD_East Coast	4/4	2	103	○		:
DrPc	R&B	4696	FA_East Coast	4/4	1	103	○		:
DrPc	R&B	4697	FB_East Coast	4/4	1	103	○		:
DrPc	R&B	4698	FC_East Coast	4/4	1	103	○		:
DrPc	R&B	4699	FD_East Coast	4/4	1	103	○		:
DrPc	R&B	4700	MA1_West Coast	4/4	2	97	○		"Hip Hop Kit 2"
DrPc	R&B	4701	MB1_West Coast	4/4	2	97	○		:
DrPc	R&B	4702	MC1_West Coast	4/4	2	97	○		:
DrPc	R&B	4703	MD1_West Coast	4/4	2	97	○		:
DrPc	R&B	4704	FA1_West Coast	4/4	1	97	○		:
DrPc	R&B	4705	FB1_West Coast	4/4	1	97	○		:
DrPc	R&B	4706	FC1_West Coast	4/4	1	97	○		:
DrPc	R&B	4707	FD1_West Coast	4/4	1	97	○		:
DrPc	R&B	4708	MA2_West Coast	4/4	2	97	○		"Hip Hop Kit 1"
DrPc	R&B	4709	MB2_West Coast	4/4	2	97	○		:
DrPc	R&B	4710	MC2_West Coast	4/4	2	97	○		:
DrPc	R&B	4711	MD2_West Coast	4/4	2	97	○		:
DrPc	R&B	4712	FA2_West Coast	4/4	1	97	○		:
DrPc	R&B	4713	FB2_West Coast	4/4	1	97	○		:
DrPc	R&B	4714	FC2_West Coast	4/4	1	97	○		:
DrPc	R&B	4715	FD2_West Coast	4/4	1	97	○		:
DrPc	R&B	4716	MA1_South Rap 1	4/4	4	98	○		"Belly Dance Kit"
DrPc	R&B	4717	MB1_South Rap 1	4/4	4	98	○		:
DrPc	R&B	4718	MC1_South Rap 1	4/4	4	98	○		:
DrPc	R&B	4719	MD1_South Rap 1	4/4	4	98	○		:
DrPc	R&B	4720	FA1_South Rap 1	4/4	1	98	○		:
DrPc	R&B	4721	FB1_South Rap 1	4/4	1	98	○		:
DrPc	R&B	4722	FC1_South Rap 1	4/4	1	98	○		:
DrPc	R&B	4723	FD1_South Rap 1	4/4	1	98	○		:
DrPc	R&B	4724	MA2_South Rap 1	4/4	4	98	○		"Hip Hop Kit 1"
DrPc	R&B	4725	MB2_South Rap 1	4/4	4	98	○		:

Main Category	Sub Category	ARP No.	ARP Name	Time Signature	Length	Original Tempo	Accent	Random SFX	Voice Type
DrPc	R&B	4726	MC2_South Rap 1	4/4	4	98	○		"Hip Hop Kit 1"
DrPc	R&B	4727	MD2_South Rap 1	4/4	4	98	○		:
DrPc	R&B	4728	FA2_South Rap 1	4/4	1	98	○		:
DrPc	R&B	4729	FB2_South Rap 1	4/4	1	98	○		:
DrPc	R&B	4730	FC2_South Rap 1	4/4	1	98	○		:
DrPc	R&B	4731	FD2_South Rap 1	4/4	1	98	○		:
DrPc	R&B	4732	MB1_South Rap 2	4/4	2	90	○		"Hip Hop Kit 2"
DrPc	R&B	4733	MC1_South Rap 2	4/4	2	90	○		:
DrPc	R&B	4734	MD1_South Rap 2	4/4	2	90	○		:
DrPc	R&B	4735	FA1_South Rap 2	4/4	1	90	○		:
DrPc	R&B	4736	FB1_South Rap 2	4/4	1	90	○		:
DrPc	R&B	4737	FC1_South Rap 2	4/4	1	90	○		:
DrPc	R&B	4738	FD1_South Rap 2	4/4	1	90	○		:
DrPc	R&B	4739	MA2_South Rap 2	4/4	2	90	○		"Hip Hop Kit 1"
DrPc	R&B	4740	MB2_South Rap 2	4/4	2	90	○		:
DrPc	R&B	4741	MC2_South Rap 2	4/4	2	90	○		:
DrPc	R&B	4742	MD2_South Rap 2	4/4	2	90	○		:
DrPc	R&B	4743	FA2_South Rap 2	4/4	1	90	○		:
DrPc	R&B	4744	FB2_South Rap 2	4/4	1	90	○		:
DrPc	R&B	4745	FC2_South Rap 2	4/4	1	90	○		:
DrPc	R&B	4746	FD2_South Rap 2	4/4	1	90	○		:
DrPc	R&B	4747	MA_Hip Hop 1	4/4	2	105	○		"Hip Hop Kit 3"
DrPc	R&B	4748	MB_Hip Hop 1	4/4	2	105	○		:
DrPc	R&B	4749	MC_Hip Hop 1	4/4	2	105	○		:
DrPc	R&B	4750	MD_Hip Hop 1	4/4	2	105	○		:
DrPc	R&B	4751	IA_Hip Hop 1	4/4	1	105	○		:
DrPc	R&B	4752	FA_Hip Hop 1	4/4	1	105	○		:
DrPc	R&B	4753	FB_Hip Hop 1	4/4	1	105	○		:
DrPc	R&B	4754	FC_Hip Hop 1	4/4	2	105	○		:
DrPc	R&B	4755	MA_Hip Hop 2	4/4	2	104	○		:
DrPc	R&B	4756	MB_Hip Hop 2	4/4	2	104	○		:
DrPc	R&B	4757	MC_Hip Hop 2	4/4	2	104	○		:
DrPc	R&B	4758	MD_Hip Hop 2	4/4	2	104	○		:
DrPc	R&B	4759	IA_Hip Hop 2	4/4	1	104	○		:
DrPc	R&B	4760	FA_Hip Hop 2	4/4	1	104	○		:
DrPc	R&B	4761	FB_Hip Hop 2	4/4	1	104	○		:
DrPc	R&B	4762	FC_Hip Hop 2	4/4	2	104	○		:
DrPc	R&B	4763	MA_Hip Hop 3	4/4	2	94	○		"Break Kit"
DrPc	R&B	4764	MB_Hip Hop 3	4/4	2	94	○		:
DrPc	R&B	4765	MC_Hip Hop 3	4/4	2	94	○		:
DrPc	R&B	4766	MD_Hip Hop 3	4/4	2	94	○		:
DrPc	R&B	4767	IA_Hip Hop 3	4/4	2	94	○		:
DrPc	R&B	4768	FA_Hip Hop 3	4/4	1	94	○		:
DrPc	R&B	4769	FB_Hip Hop 3	4/4	1	94	○		:
DrPc	R&B	4770	FC_Hip Hop 3	4/4	2	94	○		:
DrPc	R&B	4771	MA_Hip Hop 4	4/4	2	96	○		"Hip Hop Kit 1"
DrPc	R&B	4772	MA1_Hip Hop 5	4/4	2	103	○		:
DrPc	R&B	4773	MB1_Hip Hop 5	4/4	4	103	○		:
DrPc	R&B	4774	MC1_Hip Hop 5	4/4	2	103	○		:
DrPc	R&B	4775	MD1_Hip Hop 5	4/4	2	103	○		:
DrPc	R&B	4776	FA1_Hip Hop 5	4/4	1	103	○		:
DrPc	R&B	4777	FB1_Hip Hop 5	4/4	1	103	○		:
DrPc	R&B	4778	FC1_Hip Hop 5	4/4	1	103	○		:
DrPc	R&B	4779	FD1_Hip Hop 5	4/4	1	103	○		:
DrPc	R&B	4780	MA2_Hip Hop 5	4/4	2	103	○		"Nu Hip Hop Kit 2"
DrPc	R&B	4781	MB2_Hip Hop 5	4/4	4	103	○		:
DrPc	R&B	4782	MC2_Hip Hop 5	4/4	2	103	○		:
DrPc	R&B	4783	MD2_Hip Hop 5	4/4	2	103	○		:
DrPc	R&B	4784	FA2_Hip Hop 5	4/4	1	103	○		:
DrPc	R&B	4785	FB2_Hip Hop 5	4/4	1	103	○		:
DrPc	R&B	4786	FC2_Hip Hop 5	4/4	1	103	○		:
DrPc	R&B	4787	FD2_Hip Hop 5	4/4	1	103	○		:
DrPc	R&B	4788	MA_Hip Hop 6	4/4	4	96	○		"Hip Hop Kit 1"
DrPc	R&B	4789	MB_Hip Hop 6	4/4	4	96	○		:
DrPc	R&B	4790	MC_Hip Hop 6	4/4	4	96	○		:
DrPc	R&B	4791	FA_Hip Hop 6	4/4	1	96	○		:
DrPc	R&B	4792	FB_Hip Hop 6	4/4	1	96	○		:
DrPc	R&B	4793	FC_Hip Hop 6	4/4	1	96	○		:
DrPc	R&B	4794	BA_Hip Hop 6	4/4	1	96	○		:
DrPc	R&B	4795	MA1_Hip Break	4/4	4	98	○		:
DrPc	R&B	4796	MB1_Hip Break	4/4	4	98	○		:
DrPc	R&B	4797	MC1_Hip Break	4/4	4	98	○		:
DrPc	R&B	4798	FA1_Hip Break	4/4	1	98	○		:
DrPc	R&B	4799	FB1_Hip Break	4/4					

Arpeggio Type List

Main Category	Sub Category	ARP No.	ARP Name	Time Signature	Length	Original Tempo	Accent	Random SFX	Voice Type
DrPc	R&B	4809	MA_Hip Rock 1	4/4	4	90	○		*Rock Stereo Kit 2*
DrPc	R&B	4810	MB_Hip Rock 1	4/4	4	90	○		:
DrPc	R&B	4811	MC_Hip Rock 1	4/4	4	90	○		:
DrPc	R&B	4812	FA_Hip Rock 1	4/4	1	90	○		:
DrPc	R&B	4813	FB_Hip Rock 1	4/4	1	90	○		:
DrPc	R&B	4814	FC_Hip Rock 1	4/4	1	90	○		:
DrPc	R&B	4815	BA_Hip Rock 1	4/4	1	90	○		:
DrPc	R&B	4816	MA_Hip Rock 2	4/4	4	132	○		*House Kit 2*
DrPc	R&B	4817	MB_Hip Rock 2	4/4	4	132	○		:
DrPc	R&B	4818	MC_Hip Rock 2	4/4	4	132	○		:
DrPc	R&B	4819	FA_Hip Rock 2	4/4	1	132	○		:
DrPc	R&B	4820	FB_Hip Rock 2	4/4	1	132	○		:
DrPc	R&B	4821	FC_Hip Rock 2	4/4	1	132	○		:
DrPc	R&B	4822	BA_Hip Rock 2	4/4	1	132	○		:
DrPc	R&B	4823	MA1_Hip Reggae	4/4	4	92	○		*House Kit 1*
DrPc	R&B	4824	MB1_Hip Reggae	4/4	4	92	○		:
DrPc	R&B	4825	MC1_Hip Reggae	4/4	4	92	○		:
DrPc	R&B	4826	FA1_Hip Reggae	4/4	1	92	○		:
DrPc	R&B	4827	FB1_Hip Reggae	4/4	1	92	○		:
DrPc	R&B	4828	FC1_Hip Reggae	4/4	1	92	○		:
DrPc	R&B	4829	BA1_Hip Reggae	4/4	1	92	○		:
DrPc	R&B	4830	MA2_Hip Reggae	4/4	4	92	○		*Latin Percussion Kit*
DrPc	R&B	4831	MB2_Hip Reggae	4/4	4	92	○		:
DrPc	R&B	4832	MC2_Hip Reggae	4/4	4	92	○		:
DrPc	R&B	4833	FA2_Hip Reggae	4/4	1	92	○		:
DrPc	R&B	4834	FB2_Hip Reggae	4/4	1	92	○		:
DrPc	R&B	4835	FC2_Hip Reggae	4/4	1	92	○		:
DrPc	R&B	4836	BA2_Hip Reggae	4/4	1	92	○		:
DrPc	R&B	4837	MA1_Regeton	4/4	4	98	○		*Hip Hop Kit 1*
DrPc	R&B	4838	MB1_Regeton	4/4	4	98	○		:
DrPc	R&B	4839	MC1_Regeton	4/4	4	98	○		:
DrPc	R&B	4840	FA1_Regeton	4/4	1	98	○		:
DrPc	R&B	4841	FB1_Regeton	4/4	1	98	○		:
DrPc	R&B	4842	FC1_Regeton	4/4	1	98	○		:
DrPc	R&B	4843	BA1_Regeton	4/4	1	98	○		:
DrPc	R&B	4844	MA2_Regeton	4/4	4	98	○		*Percussion Kit*
DrPc	R&B	4845	MB2_Regeton	4/4	4	98	○		:
DrPc	R&B	4846	MC2_Regeton	4/4	4	98	○		:
DrPc	R&B	4847	FA2_Regeton	4/4	1	98	○		:
DrPc	R&B	4848	FB2_Regeton	4/4	1	98	○		:
DrPc	R&B	4849	FC2_Regeton	4/4	1	98	○		:
DrPc	R&B	4850	BA2_Regeton	4/4	1	98	○		:
DrPc	R&B	4851	MA_Hip Ethnic 1	4/4	2	94	○		*Hip Hop Kit 1*
DrPc	R&B	4852	MB_Hip Ethnic 1	4/4	2	94	○		:
DrPc	R&B	4853	MC_Hip Ethnic 1	4/4	2	94	○		:
DrPc	R&B	4854	MD_Hip Ethnic 1	4/4	2	94	○		:
DrPc	R&B	4855	ME_Hip Ethnic 1	4/4	2	94	○		:
DrPc	R&B	4856	MF_Hip Ethnic 1	4/4	2	94	○		:
DrPc	R&B	4857	BA_Hip Ethnic 1	4/4	1	94	○		:
DrPc	R&B	4858	MA_Hip Ethnic 2	4/4	2	110	○		:
DrPc	R&B	4859	MB_Hip Ethnic 2	4/4	2	110	○		:
DrPc	R&B	4860	MC_Hip Ethnic 2	4/4	2	110	○		:
DrPc	R&B	4861	MD_Hip Ethnic 2	4/4	2	110	○		:
DrPc	R&B	4862	ME_Hip Ethnic 2	4/4	2	110	○		:
DrPc	R&B	4863	MF_Hip Ethnic 2	4/4	2	110	○		:
DrPc	R&B	4864	BA_Hip Ethnic 2	4/4	1	110	○		:
DrPc	R&B	4865	MA_ClasHipHop	4/4	2	90	○		*Hip Hop Kit 3*
DrPc	R&B	4866	MB_ClasHipHop	4/4	1	90	○		:
DrPc	R&B	4867	MC_ClasHipHop	4/4	1	90	○		:
DrPc	R&B	4868	MD_ClasHipHop	4/4	2	90	○		:
DrPc	R&B	4869	IA_ClasHipHop/1a	4/4	2	90	○		:
DrPc	R&B	4870	IA_ClasHipHop/1b	4/4	1	90	○		:
DrPc	R&B	4871	FA_ClasHipHop	4/4	1	90	○		:
DrPc	R&B	4872	FB_ClasHipHop	4/4	1	90	○		:
DrPc	R&B	4873	IA_ClasHipHop/2	4/4	4	90	○		:
DrPc	R&B	4874	MA_i-Hop	4/4	4	98	○		:
DrPc	R&B	4875	MB_i-Hop	4/4	4	98	○		:
DrPc	R&B	4876	MC_i-Hop	4/4	4	98	○		:
DrPc	R&B	4877	MD_i-Hop	4/4	1	98	○		:
DrPc	R&B	4878	MA_Gangsta	4/4	2	98	○		*Hip Hop Kit 4*
DrPc	R&B	4879	MB_Gangsta	4/4	4	98	○		:
DrPc	R&B	4880	MC_Gangsta	4/4	4	98	○		:
DrPc	R&B	4881	MD_Gangsta	4/4	2	98	○		:
DrPc	R&B	4882	MA_Jazz Hop	4/4	2	106	○		*Hip Hop Kit 2*
DrPc	R&B	4883	MA_HipHop Loop1	4/4	4	97	○		*Nu Hip Hop Kit 1*
DrPc	R&B	4884	MA_HipHop Loop2	4/4	4	81	○		:
DrPc	R&B	4885	MA_HipHop Loop3	4/4	4	96	○		:
DrPc	R&B	4886	MA_HipHop Loop4	4/4	4	93	○		:
DrPc	R&B	4887	MA_HipHop Loop5	4/4	4	94	○		:
DrPc	R&B	4888	MA_HipHop Loop6	4/4	4	95	○		:
DrPc	R&B	4889	MA_HipHop Loop7	4/4	4	100	○		:
DrPc	R&B	4890	MA_HipHop Loop8	4/4	4	87	○		:
DrPc	R&B	4891	MA_HipHop Loop9	4/4	4	97	○		:

Main Category	Sub Category	ARP No.	ARP Name	Time Signature	Length	Original Tempo	Accent	Random SFX	Voice Type
DrPc	R&B	4892	MA_HipHopLoop10	4/4	4	95	○		*Nu Hip Hop Kit 1*
DrPc	R&B	4893	MA_HipHopLoop11	4/4	4	96	○		:
DrPc	R&B	4894	MA_HipHopLoop12	4/4	2	100	○		:
DrPc	R&B	4895	MA_HipHopLoop13	4/4	2	100	○		:
DrPc	R&B	4896	MA_HipHopLoop14	4/4	1	81	○		:
DrPc	R&B	4897	MA_HipHopLoop15	4/4	1	97	○		:
DrPc	R&B	4898	MA_HipHopLoop16	4/4	2	100	○		:
DrPc	R&B	4899	MA_HipHopLoop17	4/4	2	75	○		:
DrPc	R&B	4900	MA_ChillKitHip1	4/4	2	90	○		*Chill Out Kit*
DrPc	R&B	4901	MA_ChillKitHip2	4/4	2	90	○		*8Z Chilly Breakz*
DrPc	R&B	4902	MA_ChillKitHip3	4/4	2	90	○		*Chill Out Kit*
DrPc	R&B	4903	MA_ChillKitHip4	4/4	2	90	○		:
DrPc	R&B	4904	MA_8Z HeavyHip1	4/4	2	90	○		*8Z Glitch*
DrPc	R&B	4905	MA_8Z HeavyHip2	4/4	2	90	○		:
DrPc	R&B	4906	MA_8Z ElectrHip1	4/4	4	90	○		*8Z Heavy Hearts*
DrPc	R&B	4907	MA_8Z ElectrHip2	4/4	2	90	○		:
DrPc	R&B	4908	MA_Soul 1	4/4	2	116	○		*Power Standard Kit 1*
DrPc	R&B	4909	MB_Soul 1	4/4	2	116	○		:
DrPc	R&B	4910	MC_Soul 1	4/4	2	116	○		:
DrPc	R&B	4911	FA_Soul 1	4/4	1	116	○		:
DrPc	R&B	4912	FB_Soul 1	4/4	1	116	○		:
DrPc	R&B	4913	FC_Soul 1	4/4	1	116	○		:
DrPc	R&B	4914	BA_Soul 1	4/4	1	116	○		:
DrPc	R&B	4915	MA_Soul 2	4/4	4	120	○		*Dry Standard Kit*
DrPc	R&B	4916	MB_Soul 2	4/4	4	120	○		:
DrPc	R&B	4917	MC_Soul 2	4/4	4	120	○		:
DrPc	R&B	4918	MD_Soul 2	4/4	4	120	○		:
DrPc	R&B	4919	IA_Soul 2	4/4	1	120	○		:
DrPc	R&B	4920	FA_Soul 2	4/4	1	120	○		:
DrPc	R&B	4921	FB_Soul 2	4/4	1	120	○		:
DrPc	R&B	4922	FC_Soul 2	4/4	4	120	○		:
DrPc	R&B	4923	MA1_Soul 3	4/4	4	88	○		*Hip Hop Kit 3*
DrPc	R&B	4924	MB1_Soul 3	4/4	4	88	○		:
DrPc	R&B	4925	MC1_Soul 3	4/4	4	88	○		:
DrPc	R&B	4926	MD1_Soul 3	4/4	4	88	○		:
DrPc	R&B	4927	FA1_Soul 3	4/4	1	88	○		:
DrPc	R&B	4928	FB1_Soul 3	4/4	1	88	○		:
DrPc	R&B	4929	FC1_Soul 3	4/4	1	88	○		:
DrPc	R&B	4930	FD1_Soul 3	4/4	1	88	○		:
DrPc	R&B	4931	MA2_Soul 3	4/4	4	88	○		*Hip Hop Kit 1*
DrPc	R&B	4932	MB2_Soul 3	4/4	4	88	○		:
DrPc	R&B	4933	MC2_Soul 3	4/4	4	88	○		:
DrPc	R&B	4934	MD2_Soul 3	4/4	4	88	○		:
DrPc	R&B	4935	FA2_Soul 3	4/4	1	88	○		:
DrPc	R&B	4936	FB2_Soul 3	4/4	1	88	○		:
DrPc	R&B	4937	FC2_Soul 3	4/4	1	88	○		:
DrPc	R&B	4938	FD2_Soul 3	4/4	1	88	○		:
DrPc	R&B	4939	MA_70sChartSoul	4/4	2	108	○		*Power Standard Kit 2*
DrPc	R&B	4940	MB_70sChartSoul	4/4	2	108	○		:
DrPc	R&B	4941	MC_70sChartSoul	4/4	2	108	○		:
DrPc	R&B	4942	FA_70sChartSoul	4/4	1	108	○		:
DrPc	R&B	4943	FB_70sChartSoul	4/4	1	108	○		:
DrPc	R&B	4944	FC_70sChartSoul	4/4	1	108	○		:
DrPc	R&B	4945	BA_70sChartSoul	4/4	1	108	○		:
DrPc	R&B	4946	MA_Frankly Soul	4/4	4	120	○		*Power Standard Kit 1*
DrPc	R&B	4947	MB_Frankly Soul	4/4	4	120	○		:
DrPc	R&B	4948	MC_Frankly Soul	4/4	4	120	○		:
DrPc	R&B	4949	FA_Frankly Soul	4/4	1	120	○		:
DrPc	R&B	4950	FB_Frankly Soul	4/4	1	120	○		:
DrPc	R&B	4951	FC_Frankly Soul	4/4	1	120	○		:
DrPc	R&B	4952	BA_Frankly Soul	4/4	1	120	○		:
DrPc	R&B	4953	MA_Soul Beat	4/4	4	124	○		:
DrPc	R&B	4954	MB_Soul Beat	4/4	4	124	○		:
DrPc	R&B	4955	MC_Soul Beat	4/4	4	124	○		:
DrPc	R&B	4956	FA_Soul Beat	4/4	1	124	○		:
DrPc	R&B	4957	FB_Soul Beat	4/4	1	124	○		:
DrPc	R&B	4958	FC_Soul Beat	4/4	1	124	○		:
DrPc	R&B	4959	BA_Soul Beat	4/4	1	124	○		:
DrPc	R&B	4960	MA_Soul Band	4/4	4	129	○		*Power Standard Kit 2*
DrPc	R&B	4961	MB_Soul Band	4/4	4	129	○		:
DrPc	R&B	4962	MC_Soul Band	4/4	4	129	○		:
DrPc	R&B	4963	FA_Soul Band	4/4	1	129	○		:
DrPc	R&B	4964	FB_Soul Band	4/4	1	129	○		:
DrPc	R&B	4965	FC_Soul Band	4/4	1	129	○		:
DrPc	R								

Arpeggio Type List

Main Category	Sub Category	ARP No.	ARP Name	Time Signature	Length	Original Tempo	Accent	Random SFX	Voice Type
DrPc	R&B	4975	MB_Soul Swing	4/4	4	124	○		*Power Standard Kit 1*
DrPc	R&B	4976	MC_Soul Swing	4/4	4	124	○		:
DrPc	R&B	4977	FA_Soul Swing	4/4	1	124	○		:
DrPc	R&B	4978	FB_Soul Swing	4/4	1	124	○		:
DrPc	R&B	4979	FC_Soul Swing	4/4	1	124	○		:
DrPc	R&B	4980	BA_Soul Swing	4/4	1	124	○		:
DrPc	R&B	4981	MA_GospelBrothr	4/4	4	108	○		:
DrPc	R&B	4982	MB_GospelBrothr	4/4	4	108	○		:
DrPc	R&B	4983	MC_GospelBrothr	4/4	4	108	○		:
DrPc	R&B	4984	FA_GospelBrothr	4/4	1	108	○		:
DrPc	R&B	4985	FB_GospelBrothr	4/4	1	108	○		:
DrPc	R&B	4986	FC_GospelBrothr	4/4	1	108	○		:
DrPc	R&B	4987	BA_GospelBrothr	4/4	1	108	○		:
DrPc	R&B	4988	MA_New Gospel	4/4	2	90	○		*Hip Hop Kit 3*
DrPc	R&B	4989	MB_New Gospel	4/4	2	90	○		:
DrPc	R&B	4990	MC_New Gospel	4/4	2	90	○		:
DrPc	R&B	4991	MD_New Gospel	4/4	2	90	○		:
DrPc	R&B	4992	IA_New Gospel	4/4	1	90	○		:
DrPc	R&B	4993	FA_New Gospel	4/4	1	90	○		:
DrPc	R&B	4994	FB_New Gospel	4/4	1	90	○		:
DrPc	R&B	4995	FC_New Gospel	4/4	2	90	○		:
DrPc	R&B	4996	MA_Gospel	3/4	4	126	○		*Dry Standard Kit*
DrPc	R&B	4997	MB_Gospel	3/4	2	126	○		:
DrPc	Elect	5005	MA_Ambient1	4/4	4	102	○		*Break Kit*
DrPc	Elect	4999	MB_Ambient1	4/4	4	102	○		:
DrPc	Elect	5000	MC_Ambient1	4/4	4	102	○		:
DrPc	Elect	5001	FA_Ambient1	4/4	1	102	○		:
DrPc	Elect	5002	FB_Ambient1	4/4	1	102	○		:
DrPc	Elect	5003	FC_Ambient1	4/4	1	102	○		:
DrPc	Elect	5004	BA_Ambient1	4/4	1	102	○		:
DrPc	Elect	5005	MA_Ambient2	4/4	4	111	○		*Belly Dance Kit*
DrPc	Elect	5006	MB_Ambient2	4/4	2	111	○		:
DrPc	Elect	5007	MC_Ambient2	4/4	4	111	○		:
DrPc	Elect	5008	FA_Ambient2	4/4	1	111	○		:
DrPc	Elect	5009	FB_Ambient2	4/4	8	111	○		:
DrPc	Elect	5010	FC_Ambient2	4/4	1	111	○		:
DrPc	Elect	5011	BA_Ambient2	4/4	2	111	○		:
DrPc	Elect	5012	MA1_Ambient3	4/4	4	88	○		*Hard Kit*
DrPc	Elect	5013	MB1_Ambient3	4/4	4	88	○		:
DrPc	Elect	5014	MC1_Ambient3	4/4	4	88	○		:
DrPc	Elect	5015	FA1_Ambient3	4/4	1	88	○		:
DrPc	Elect	5016	FB1_Ambient3	4/4	1	88	○		:
DrPc	Elect	5017	FC1_Ambient3	4/4	1	88	○		:
DrPc	Elect	5018	BA1_Ambient3	4/4	1	88	○		:
DrPc	Elect	5019	MA2_Ambient3	4/4	4	88	○		*SFX Kit*
DrPc	Elect	5020	MB2_Ambient3	4/4	4	88	○		:
DrPc	Elect	5021	MC2_Ambient3	4/4	4	88	○		:
DrPc	Elect	5022	FA2_Ambient3	4/4	1	88	○		:
DrPc	Elect	5023	FB2_Ambient3	4/4	1	88	○		:
DrPc	Elect	5024	FC2_Ambient3	4/4	1	88	○		:
DrPc	Elect	5025	BA2_Ambient3	4/4	1	88	○		:
DrPc	Elect	5026	MA3_Ambient3	4/4	4	88	○		*Pop Latin Kit*
DrPc	Elect	5027	MB3_Ambient3	4/4	4	88	○		:
DrPc	Elect	5028	MC3_Ambient3	4/4	4	88	○		:
DrPc	Elect	5029	FA3_Ambient3	4/4	1	88	○		:
DrPc	Elect	5030	FB3_Ambient3	4/4	1	88	○		:
DrPc	Elect	5031	FC3_Ambient3	4/4	1	88	○		:
DrPc	Elect	5032	BA3_Ambient3	4/4	1	88	○		:
DrPc	Elect	5033	MA1_Chill Out	4/4	2	79	○		*Dry Standard Kit*
DrPc	Elect	5034	MB1_Chill Out	4/4	2	79	○		:
DrPc	Elect	5035	MC1_Chill Out	4/4	4	79	○		:
DrPc	Elect	5036	MD1_Chill Out	4/4	2	79	○		:
DrPc	Elect	5037	IA1_Chill Out	4/4	1	79	○		:
DrPc	Elect	5038	FA1_Chill Out	4/4	1	79	○		:
DrPc	Elect	5039	FB1_Chill Out	4/4	1	79	○		:
DrPc	Elect	5040	FC1_Chill Out	4/4	4	79	○		:
DrPc	Elect	5041	MA2_Chill Out	4/4	2	79	○		*Break Kit*
DrPc	Elect	5042	MB2_Chill Out	4/4	2	79	○		:
DrPc	Elect	5043	MC2_Chill Out	4/4	4	79	○		:
DrPc	Elect	5044	MD2_Chill Out	4/4	2	79	○		:
DrPc	Elect	5045	IA2_Chill Out	4/4	4	79	○		:
DrPc	Elect	5046	FA2_Chill Out	4/4	1	79	○		:
DrPc	Elect	5047	FB2_Chill Out	4/4	1	79	○		:
DrPc	Elect	5048	FC2_Chill Out	4/4	4	79	○		:
DrPc	Elect	5049	MA_ChillKit1 /1	4/4	4	85	○		*Chill Out Kit*
DrPc	Elect	5050	MA_ChillKit1 /2	4/4	4	85	○		:
DrPc	Elect	5051	MA_ChillKit1 /3	4/4	4	85	○		:
DrPc	Elect	5052	MA_ChillKit1 /4	4/4	4	85	○		:
DrPc	Elect	5053	MA_ChillKit1 /5	4/4	4	85	○		:
DrPc	Elect	5054	MA_ChillKit2 /1	4/4	4	85	○		:
DrPc	Elect	5055	MA_ChillKit2 /2	4/4	4	85	○		:
DrPc	Elect	5056	MA_ChillKit2 /3	4/4	4	85	○		:
DrPc	Elect	5057	MA_ChillKit2 /4	4/4	4	85	○		:

Main Category	Sub Category	ARP No.	ARP Name	Time Signature	Length	Original Tempo	Accent	Random SFX	Voice Type
DrPc	Elect	5058	MA_ChillOutBreak1	4/4	4	85	○		*Chill Out Kit*
DrPc	Elect	5059	MA_ChillOutBreak2	4/4	4	85	○		:
DrPc	Elect	5060	MA_ChillOutBreak3	4/4	4	85	○		:
DrPc	Elect	5061	MA_ChillOutBreak4	4/4	4	85	○		:
DrPc	Elect	5062	MA_8Z ChillBrk1	4/4	4	85	○		*8Z Chilly Breakz*
DrPc	Elect	5063	MA_8Z ChillBrk2	4/4	4	85	○		:
DrPc	Elect	5064	MA_8Z ChillBrk3	4/4	4	85	○		:
DrPc	Elect	5065	MA_8Z ChillBrk4	4/4	4	85	○		:
DrPc	Elect	5066	MA_8Z ChillBrk5	4/4	4	85	○		:
DrPc	Elect	5067	MA_ClassicAmbi1	4/4	8	85	○		*Chill Out Kit*
DrPc	Elect	5068	MA_ClassicAmbi2	4/4	1	85	○		:
DrPc	Elect	5069	MA_ChillOutSoft	4/4	1	85	○		:
DrPc	Elect	5070	MA_ChillOutHard	4/4	2	85	○		:
DrPc	Elect	5071	MA_Pop Breaks 1	4/4	2	90	○		:
DrPc	Elect	5072	MA_8Z PopBreak2	4/4	4	90	○		*8Z Glitch*
DrPc	Elect	5073	MA_8Z PopBreak3	4/4	4	90	○		:
DrPc	Elect	5074	MA_8Z GatedBt1	4/4	4	85	○		*8Z Gated Beatz*
DrPc	Elect	5075	MA_8Z GatedBt2	4/4	4	85	○		:
DrPc	Elect	5076	MA_8Z GatedBt3	4/4	4	85	○		:
DrPc	Elect	5077	MA_8Z GatedBt4	4/4	4	85	○		:
DrPc	Elect	5078	MA_8Z GatedBt5	4/4	4	85	○		:
DrPc	Elect	5079	MA_8Z HeavyHrt1	4/4	4	85	○		*8Z Heavy Hearts*
DrPc	Elect	5080	MA_8Z HeavyHrt2	4/4	4	85	○		:
DrPc	Elect	5081	MA_8Z HeavyHrt3	4/4	4	85	○		:
DrPc	Elect	5082	MA_8Z HeavyHrt4	4/4	4	85	○		:
DrPc	Elect	5083	MA_8Z HeavyHrt5	4/4	4	85	○		:
DrPc	Elect	5084	MA1_Synth Pop1	4/4	4	90	○		*House Kit 1*
DrPc	Elect	5085	MB1_Synth Pop1	4/4	4	90	○		:
DrPc	Elect	5086	MC1_Synth Pop1	4/4	4	90	○		:
DrPc	Elect	5087	MD1_Synth Pop1	4/4	4	90	○		:
DrPc	Elect	5088	FC1_Synth Pop1	4/4	4	90	○		:
DrPc	Elect	5089	MC2_Synth Pop1	4/4	2	90	○		:
DrPc	Elect	5090	MD2_Synth Pop1	4/4	2	90	○		:
DrPc	Elect	5091	FC2_Synth Pop1	4/4	4	90	○		:
DrPc	Elect	5092	ME3_Synth Pop1	4/4	2	90	○		*Hip Hop Kit 3*
DrPc	Elect	5093	ME4_Synth Pop1	4/4	2	90	○		*House Kit 1*
DrPc	Elect	5094	MA_Synth Pop2	4/4	2	90	○		*Synth Pop Kit*
DrPc	Elect	5095	MB_Synth Pop2	4/4	2	90	○		:
DrPc	Elect	5096	MC_Synth Pop2	4/4	2	90	○		:
DrPc	Elect	5097	MD_Synth Pop2	4/4	2	90	○		:
DrPc	Elect	5098	ME_Synth Pop2	4/4	2	90	○		:
DrPc	Elect	5099	MA1_8Z Undergrnd	4/4	4	100	○		*8Z Noize Xpress*
DrPc	Elect	5100	MB1_8Z Undergrnd	4/4	4	100	○		:
DrPc	Elect	5101	MC1_8Z Undergrnd	4/4	4	100	○		:
DrPc	Elect	5102	FA1_8Z Undergrnd	4/4	1	100	○		:
DrPc	Elect	5103	FB1_8Z Undergrnd	4/4	1	100	○		:
DrPc	Elect	5104	FC1_8Z Undergrnd	4/4	1	100	○		:
DrPc	Elect	5105	BA1_8Z Undergrnd	4/4	1	100	○		:
DrPc	Elect	5106	MA2_8Z Undergrnd	4/4	4	100	○		*8Z Oxidized*
DrPc	Elect	5107	MB2_8Z Undergrnd	4/4	4	100	○		:
DrPc	Elect	5108	MC2_8Z Undergrnd	4/4	4	100	○		:
DrPc	Elect	5109	FA2_8Z Undergrnd	4/4	1	100	○		:
DrPc	Elect	5110	FB2_8Z Undergrnd	4/4	1	100	○		:
DrPc	Elect	5111	FC2_8Z Undergrnd	4/4	1	100	○		:
DrPc	Elect	5112	BA2_8Z Undergrnd	4/4	1	100	○		:
DrPc	Elect	5113	MA3_Underground	4/4	4	100	○		*Acid Kit*
DrPc	Elect	5114	MB3_Underground	4/4	4	100	○		:
DrPc	Elect	5115	MC3_Underground	4/4	4	100	○		:
DrPc	Elect	5116	FA3_Underground	4/4	1	100	○		:
DrPc	Elect	5117	FB3_Underground	4/4	1	100	○		:
DrPc	Elect	5118	FC3_Underground	4/4	1	100	○		:
DrPc	Elect	5119	BA3_Underground	4/4	1	100	○		:
DrPc	Elect	5120	MA4_Underground	4/4	4	100	○		*Hard Kit*
DrPc	Elect	5121	MB4_Underground	4/4	4	100	○		:
DrPc	Elect	5122	MC4_Underground	4/4	4	100	○		:
DrPc	Elect	5123	FA4_Underground	4/4	1	100	○		:
DrPc	Elect	5124	FB4_Underground	4/4	1	100	○		:
DrPc	Elect	5125	FC4_Underground	4/4	1	100	○		:
DrPc	Elect	5126	BA4_Underground	4/4	1	100	○		:
DrPc	Elect	5127	MA_8Z Destruct	4/4	4	115	○		*8Z Destruct*
DrPc	Elect	5128	MB_8Z Destruct	4/4	4	115	○		:
DrPc	Elect	5129	MC_8Z Destruct	4/4	4	115	○		:
DrPc	Elect	5130	MD_8Z Destruct	4/4	4	115	○		:
DrPc	Elect	5131	ME_8Z Destruct	4/4	2	115	○		:
DrPc	Elect	5132	MA_8Z Jarrin	4/4	2	105	○		*8Z Jarrin*
DrPc	Elect	5133	MB_8Z Jarrin	4/4	4	105	○		:
DrPc	Elect	5134	MC_8Z Jarrin	4/4	4	105	○		:
DrPc									

Arpeggio Type List

Main Category	Sub Category	ARP No.	ARP Name	Time Signature	Length	Original Tempo	Accent	Random SFX	Voice Type
DrPc	Elect	5141	ME_8Z Romps	4/4	2	125	○		"8Z Romps"
DrPc	Elect	5142	MA_Dub Element	4/4	2	120	○		"8Z Dub Element"
DrPc	Elect	5143	MB_Dub Element	4/4	2	120	○		:
DrPc	Elect	5144	MC_Dub Element	4/4	2	120	○		:
DrPc	Elect	5145	FA_Dub Element	4/4	1	120	○		:
DrPc	Elect	5146	FB_Dub Element	4/4	2	120	○		:
DrPc	Elect	5147	FC_Dub Element	4/4	1	120	○		:
DrPc	Elect	5148	BA_Dub Element	4/4	1	120	○		:
DrPc	Elect	5149	MA_Electronica1	4/4	1	118	○		"Tekno Kit"
DrPc	Elect	5150	MA_Electronica2	4/4	1	118	○		"Analog T9 Kit"
DrPc	Elect	5151	MA_8Z Heartbrek	4/4	4	90	○		"8Z Heavy Hearts"
DrPc	Elect	5152	MA_Sp SFX	4/4	4	100	○		"Special SFXs"
DrPc	Elect	5153	MB_Sp SFX	4/4	4	100	○		:
DrPc	Elect	5154	MC_Sp SFX	4/4	2	100	○		:
DrPc	Elect	5155	FA_Sp SFX	4/4	1	100	○		:
DrPc	Elect	5156	FB_Sp SFX	4/4	2	100	○		:
DrPc	Elect	5157	FC_Sp SFX	4/4	2	100	○		:
DrPc	Elect	5158	BA_Sp SFX	4/4	1	100	○		:
DrPc	Elect	5159	MA_Big Beat 1	4/4	4	115	○		"Break Kit"
DrPc	Elect	5160	MB_Big Beat 1	4/4	4	115	○		:
DrPc	Elect	5161	MC_Big Beat 1	4/4	4	115	○		:
DrPc	Elect	5162	FA_Big Beat 1	4/4	1	115	○		:
DrPc	Elect	5163	FB_Big Beat 1	4/4	1	115	○		:
DrPc	Elect	5164	FC_Big Beat 1	4/4	1	115	○		:
DrPc	Elect	5165	BA_Big Beat 1	4/4	1	115	○		:
DrPc	Elect	5166	MA1_Big Beat 2	4/4	4	145	○		:
DrPc	Elect	5167	MB1_Big Beat 2	4/4	8	145	○		:
DrPc	Elect	5168	MC1_Big Beat 2	4/4	4	145	○		:
DrPc	Elect	5169	FA1_Big Beat 2	4/4	1	145	○		:
DrPc	Elect	5170	FB1_Big Beat 2	4/4	1	145	○		:
DrPc	Elect	5171	FC1_Big Beat 2	4/4	1	145	○		:
DrPc	Elect	5172	BA1_Big Beat 2	4/4	2	145	○		:
DrPc	Elect	5173	MA2_Big Beat 2	4/4	4	145	○		"Trance Kit"
DrPc	Elect	5174	MB2_Big Beat 2	4/4	8	145	○		:
DrPc	Elect	5175	MC2_Big Beat 2	4/4	4	145	○		:
DrPc	Elect	5176	FA2_Big Beat 2	4/4	1	145	○		:
DrPc	Elect	5177	FB2_Big Beat 2	4/4	1	145	○		:
DrPc	Elect	5178	FC2_Big Beat 2	4/4	1	145	○		:
DrPc	Elect	5179	BA2_Big Beat 2	4/4	2	145	○		:
DrPc	Elect	5180	MA_Big Beat 3	4/4	2	120	○		"Big Kit"
DrPc	Elect	5181	MB_Big Beat 3	4/4	1	120	○		:
DrPc	Elect	5182	MA_Big Beat 4	4/4	1	138	○		:
DrPc	Elect	5183	MA_Big Beat 5	4/4	1	128	○		:
DrPc	Elect	5184	MA_Big Beat 6	4/4	4	120	○		"Rock Stereo Kit 2"
DrPc	Elect	5185	MA_Big Beat 7	4/4	4	136	○		"Big Kit"
DrPc	Elect	5186	MA_Big Beat 8	4/4	1	135	○		:
DrPc	Elect	5187	MA_Big Beat 9	4/4	1	132	○		:
DrPc	Elect	5188	MA_Big Beat 10	4/4	2	124	○		:
DrPc	Elect	5189	MA_Big Beat 11	4/4	1	120	○		:
DrPc	Elect	5190	MA_Break Trance	4/4	1	130	○		"Tekno Kit"
DrPc	Elect	5191	MA1_Breakbeats 1	4/4	4	115	○		"Break Kit"
DrPc	Elect	5192	MB1_Breakbeats 1	4/4	4	115	○		:
DrPc	Elect	5193	MC1_Breakbeats 1	4/4	2	115	○		:
DrPc	Elect	5194	FA1_Breakbeats 1	4/4	1	115	○		:
DrPc	Elect	5195	FB1_Breakbeats 1	4/4	1	115	○		:
DrPc	Elect	5196	FC1_Breakbeats 1	4/4	1	115	○		:
DrPc	Elect	5197	BA1_Breakbeats 1	4/4	1	115	○		:
DrPc	Elect	5198	MA2_8Z Breakbt1	4/4	4	115	○		"8Z Jarrin"
DrPc	Elect	5199	MB2_8Z Breakbt1	4/4	4	115	○		:
DrPc	Elect	5200	MC2_8Z Breakbt1	4/4	2	115	○		:
DrPc	Elect	5201	FA2_8Z Breakbt1	4/4	1	115	○		:
DrPc	Elect	5202	FB2_8Z Breakbt1	4/4	1	115	○		:
DrPc	Elect	5203	FC2_8Z Breakbt1	4/4	1	115	○		:
DrPc	Elect	5204	BA2_8Z Breakbt1	4/4	1	115	○		:
DrPc	Elect	5205	MA1_Breakbeats 2	4/4	4	88	○		"Drum'n'Bass Kit"
DrPc	Elect	5206	MB1_Breakbeats 2	4/4	4	88	○		:
DrPc	Elect	5207	MC1_Breakbeats 2	4/4	4	88	○		:
DrPc	Elect	5208	FA1_Breakbeats 2	4/4	1	88	○		:
DrPc	Elect	5209	FB1_Breakbeats 2	4/4	1	88	○		:
DrPc	Elect	5210	FC1_Breakbeats 2	4/4	1	88	○		:
DrPc	Elect	5211	BA1_Breakbeats 2	4/4	1	88	○		:
DrPc	Elect	5212	MA2_Breakbeats 2	4/4	4	88	○		"Big Kit"
DrPc	Elect	5213	MB2_Breakbeats 2	4/4	4	88	○		:
DrPc	Elect	5214	MC2_Breakbeats 2	4/4	4	88	○		:
DrPc	Elect	5215	FA2_Breakbeats 2	4/4	1	88	○		:
DrPc	Elect	5216	FB2_Breakbeats 2	4/4	1	88	○		:
DrPc	Elect	5217	FC2_Breakbeats 2	4/4	1	88	○		:
DrPc	Elect	5218	BA2_Breakbeats 2	4/4	1	88	○		:
DrPc	Elect	5219	MA_Lo Beat 1	4/4	2	140	○		"Break Kit"
DrPc	Elect	5220	MA_Lo Beat 2	4/4	2	130	○		:
DrPc	Elect	5221	MA_Lo Beat 3	4/4	1	122	○		:
DrPc	Elect	5222	MA_Lo Beat 4	4/4	1	115	○		:
DrPc	Elect	5223	MA_Lo Beat 5	4/4	4	180	○		:

Main Category	Sub Category	ARP No.	ARP Name	Time Signature	Length	Original Tempo	Accent	Random SFX	Voice Type
DrPc	Elect	5224	MA_Lo Beat 6	4/4	1	87	○		"Break Kit"
DrPc	Elect	5225	MA_Abstract	4/4	2	86	○		"Hip Hop Kit 2"
DrPc	Elect	5226	MA_Drum'n'Bass1	4/4	1	170	○		"Jungle Kit"
DrPc	Elect	5227	MA_Drum'n'Bass2	4/4	2	165	○		:
DrPc	Elect	5228	MA_Drum'n'Bass3	4/4	2	154	○		"Drum'n'Bass Kit"
DrPc	Elect	5229	MB_Drum'n'Bass3	4/4	2	154	○		:
DrPc	Elect	5230	MC_Drum'n'Bass3	4/4	2	154	○		:
DrPc	Elect	5231	MD_Drum'n'Bass3	4/4	1	154	○		:
DrPc	Elect	5232	ME_Drum'n'Bass3	4/4	2	154	○		:
DrPc	Elect	5233	MA_Drum'n'Bass4	4/4	1	170	○		:
DrPc	Elect	5234	MA_Techno 1	4/4	4	135	○		"House Kit 2"
DrPc	Elect	5235	MB_Techno 1	4/4	8	135	○		:
DrPc	Elect	5236	MC_Techno 1	4/4	8	135	○		:
DrPc	Elect	5237	FA_Techno 1	4/4	1	135	○		:
DrPc	Elect	5238	FB_Techno 1	4/4	1	135	○		:
DrPc	Elect	5239	FC_Techno 1	4/4	1	135	○		:
DrPc	Elect	5240	BA_Techno 1	4/4	4	135	○		:
DrPc	Elect	5241	MA_Techno 2	4/4	4	137	○		"Trance Kit"
DrPc	Elect	5242	MB_Techno 2	4/4	4	137	○		:
DrPc	Elect	5243	FA_Techno 2	4/4	1	137	○		:
DrPc	Elect	5244	FB_Techno 2	4/4	2	137	○		:
DrPc	Elect	5245	FC_Techno 2	4/4	2	137	○		:
DrPc	Elect	5246	MA1_8Z Trance 1	4/4	8	142	○		"8Z Psychedelic 1"
DrPc	Elect	5247	MB1_8Z Trance 1	4/4	4	142	○		:
DrPc	Elect	5248	MC1_8Z Trance 1	4/4	16	142	○		:
DrPc	Elect	5249	FA1_8Z Trance 1	4/4	2	142	○		:
DrPc	Elect	5250	FB1_8Z Trance 1	4/4	8	142	○		:
DrPc	Elect	5251	FC1_8Z Trance 1	4/4	8	142	○		:
DrPc	Elect	5252	BA1_8Z Trance 1	4/4	1	142	○		:
DrPc	Elect	5253	MA2_Trance 1	4/4	8	142	○		"Psychedelic Kit"
DrPc	Elect	5254	MB2_Trance 1	4/4	4	142	○		:
DrPc	Elect	5255	MC2_Trance 1	4/4	16	142	○		:
DrPc	Elect	5256	FA2_Trance 1	4/4	2	142	○		:
DrPc	Elect	5257	FB2_Trance 1	4/4	8	142	○		:
DrPc	Elect	5258	FC2_Trance 1	4/4	8	142	○		:
DrPc	Elect	5259	BA2_Trance 1	4/4	1	142	○		:
DrPc	Elect	5260	MA_Trance 2	4/4	8	135	○		"Trance Kit"
DrPc	Elect	5261	MB_Trance 2	4/4	8	135	○		:
DrPc	Elect	5262	MC_Trance 2	4/4	8	135	○		:
DrPc	Elect	5263	FA_Trance 2	4/4	1	135	○		:
DrPc	Elect	5264	FB_Trance 2	4/4	8	135	○		:
DrPc	Elect	5265	FC_Trance 2	4/4	1	135	○		:
DrPc	Elect	5266	BA_Trance 2	4/4	1	135	○		:
DrPc	Elect	5267	MA_8Z Trance 3	4/4	2	140	○		"8Z Psychedelic 1"
DrPc	Elect	5268	MB_8Z Trance 3	4/4	2	140	○		:
DrPc	Elect	5269	MC_8Z Trance 3	4/4	3	140	○		:
DrPc	Elect	5270	FA_8Z Trance 3	4/4	2	140	○		:
DrPc	Elect	5271	FB_8Z Trance 3	4/4	2	140	○		:
DrPc	Elect	5272	FC_8Z Trance 3	4/4	4	140	○		:
DrPc	Elect	5273	BA_8Z Trance 3	4/4	1	140	○		:
DrPc	Elect	5274	MA_Trance 4	4/4	4	130	○		"Analog T8 Kit"
DrPc	Elect	5275	MB_Trance 4	4/4	2	130	○		:
DrPc	Elect	5276	MC_Trance 4	4/4	4	130	○		:
DrPc	Elect	5277	FA_Trance 4	4/4	4	130	○		:
DrPc	Elect	5278	FB_Trance 4	4/4	4	130	○		:
DrPc	Elect	5279	BA_Trance 4	4/4	2	130	○		:
DrPc	Elect	5280	MA_Trance 5	4/4	4	140	○		"Analog T9 Kit"
DrPc	Elect	5281	MB_Trance 5	4/4	4	140	○		:
DrPc	Elect	5282	MC_Trance 5	4/4	4	140	○		:
DrPc	Elect	5283	MD_Trance 5	4/4	4	140	○		:
DrPc	Elect	5284	IA_Trance 5	4/4	4	140	○		:
DrPc	Elect	5285	FA_Trance 5	4/4	4	140	○		:
DrPc	Elect	5286	FB_Trance 5	4/4	4	140	○		:
DrPc	Elect	5287	FC_Trance 5	4/4	4	140	○		:
DrPc	Elect	5288	ME_Trance 5/Bd1	4/4	4	140	○		:
DrPc	Elect	5289	ME_Trance 5/Bd2	4/4	4	140	○		:
DrPc	Elect	5290	ME_Trance 5/Bd3	4/4	4	140	○		:
DrPc	Elect	5291	ME_Trance 5/Bd4	4/4	4	140	○		:
DrPc	Elect	5292	ME_Trance 5/Hh1	4/4	4	140	○		:
DrPc	Elect	5293	ME_Trance 5/Hh2	4/4	2	140	○		:
DrPc	Elect	5294	ME_Trance 5/Hh3	4/4	1	140	○		:
DrPc	Elect	5295	ME_Trance 5/Hh4	4/4	1	140	○		:
DrPc	Elect	5296	ME_Trance 5/Hh5	4/4	1	140	○		:
DrPc	Elect	5297	ME_Trance 5/Hh6	4/4	1	140	○		:
DrPc	Elect	5298	ME_Trance 5/Hh7	4/4	1	140	○		:

Arpeggio Type List

Main Category	Sub Category	ARP No.	ARP Name	Time Signature	Length	Original Tempo	Accent	Random SFX	Voice Type
DrPc	Elect	5307	FA1_PsycheTrance	4/4	1	143	○		"Psychedelic Kit"
DrPc	Elect	5308	FB1_PsycheTrance	4/4	1	143	○		:
DrPc	Elect	5309	FC1_PsycheTrance	4/4	1	143	○		:
DrPc	Elect	5310	BA1_PsycheTrance	4/4	4	143	○		:
DrPc	Elect	5311	MA2_8Z Psyche	4/4	2	140	○		"8Z Psychedelic 1"
DrPc	Elect	5312	MB2_8Z Psyche	4/4	2	140	○		:
DrPc	Elect	5313	MC2_8Z Psyche	4/4	2	140	○		:
DrPc	Elect	5314	FA2_8Z Psyche	4/4	1	140	○		:
DrPc	Elect	5315	FB2_8Z Psyche	4/4	1	140	○		:
DrPc	Elect	5316	FC2_8Z Psyche	4/4	1	140	○		:
DrPc	Elect	5317	BA2_8Z Psyche	4/4	2	140	○		:
DrPc	Elect	5318	MA3_8Z Psyche	4/4	1	135	○		8Z Psychedelic 2
DrPc	Elect	5319	MB3_8Z Psyche	4/4	1	135	○		:
DrPc	Elect	5320	MC3_8Z Psyche	4/4	2	135	○		:
DrPc	Elect	5321	FA3_8Z Psyche	4/4	2	135	○		:
DrPc	Elect	5322	FB3_8Z Psyche	4/4	1	135	○		:
DrPc	Elect	5323	FC3_8Z Psyche	4/4	1	135	○		:
DrPc	Elect	5324	BA3_8Z Psyche	4/4	1	135	○		:
DrPc	Elect	5325	MA_Trance Kit 1	4/4	4	136	○		"Trance Kit"
DrPc	Elect	5326	MA_Trance Kit 2	4/4	4	136	○		:
DrPc	Elect	5327	MA_Trance Kit 3	4/4	4	136	○		:
DrPc	Elect	5328	MA_Trance Kit 4	4/4	4	136	○		:
DrPc	Elect	5329	MA_Trance Kit 5	4/4	4	136	○		:
DrPc	Elect	5330	MA_Trance Kit 6	4/4	4	136	○		:
DrPc	Elect	5331	MA_Trance Kit 7	4/4	1	136	○		:
DrPc	Elect	5332	MA_Trance Kit 8	4/4	2	136	○		:
DrPc	Elect	5333	MA_Trance Kit 9	4/4	2	136	○		:
DrPc	Elect	5334	MA_Trance Kit10	4/4	2	136	○		:
DrPc	Elect	5335	MA_Trance Kit11	4/4	2	136	○		:
DrPc	Elect	5336	MA_Trance Kit12	4/4	4	136	○		:
DrPc	Elect	5337	MA_8Z TrancBsc1	4/4	1	136	○		"8Z Trance Basics"
DrPc	Elect	5338	MA_8Z TrancBsc2	4/4	1	136	○		:
DrPc	Elect	5339	MA_8Z TrancBsc3	4/4	1	136	○		:
DrPc	Elect	5340	MA_8Z TrancBsc4	4/4	1	136	○		:
DrPc	Elect	5341	MA_8Z TrancBsc5	4/4	4	136	○		:
DrPc	Elect	5342	MA_Trance Club1	4/4	1	128	○		"Trance Kit"
DrPc	Elect	5343	MA_Trance Club2	4/4	1	128	○		:
DrPc	Elect	5344	MA_Trance Club3	4/4	1	128	○		:
DrPc	Elect	5345	MA_Trance Club4	4/4	1	128	○		:
DrPc	Elect	5346	MA_Trance Club5	4/4	1	128	○		:
DrPc	Elect	5347	MA_Trance Club6	4/4	1	128	○		:
DrPc	Elect	5348	MA_8Z EarlyLoF1	4/4	1	136	○		"8Z Early Lo-Fi"
DrPc	Elect	5349	MA_8Z EarlyLoF2	4/4	1	136	○		:
DrPc	Elect	5350	MA_8Z EarlyLoF3	4/4	1	136	○		:
DrPc	Elect	5351	MA_8Z EarlyLoF4	4/4	1	136	○		:
DrPc	Elect	5352	MA_8Z EarlyLoF5	4/4	1	136	○		:
DrPc	Elect	5353	MA_8Z NoiseXpr1	4/4	4	136	○		"8Z Noise Xpress"
DrPc	Elect	5354	MA_8Z NoiseXpr2	4/4	4	136	○		:
DrPc	Elect	5355	MA_8Z NoiseXpr3	4/4	4	136	○		:
DrPc	Elect	5356	MA_8Z NoiseXpr4	4/4	4	136	○		:
DrPc	Elect	5357	MA_8Z NoiseXpr5	4/4	4	136	○		:
DrPc	Elect	5358	MA_8Z ReversBt1	4/4	1	136	○		"8Z Reverse Beat"
DrPc	Elect	5359	MA_8Z ReversBt2	4/4	1	136	○		:
DrPc	Elect	5360	MA_8Z ReversBt3	4/4	1	136	○		:
DrPc	Elect	5361	MA_8Z ReversBt4	4/4	1	136	○		:
DrPc	Elect	5362	MA_8Z CrushDnc1	4/4	2	136	○		"8Z Crush Dance"
DrPc	Elect	5363	MA_8Z CrushDnc2	4/4	2	136	○		:
DrPc	Elect	5364	MA_8Z CrushDnc3	4/4	4	136	○		:
DrPc	Elect	5365	MA_8Z CrushDnc4	4/4	2	136	○		:
DrPc	Elect	5366	MA_8Z CrushDnc5	4/4	4	136	○		:
DrPc	Elect	5367	MA_Dream Dance	4/4	4	136	○		"House Kit 1"
DrPc	Elect	5368	MC_Dream Dance	4/4	4	136	○		:
DrPc	Elect	5369	MD_Dream Dance	4/4	4	136	○		:
DrPc	Elect	5370	IA_Dream Dance	4/4	4	136	○		:
DrPc	Elect	5371	ME_Dream Dance/Bd1	4/4	4	136	○		:
DrPc	Elect	5372	ME_Dream Dance/Bd2	4/4	1	136	○		:
DrPc	Elect	5373	ME_Dream Dance/Bd3	4/4	4	136	○		:
DrPc	Elect	5374	ME_Dream Dance/Bd4	4/4	4	136	○		:
DrPc	Elect	5375	ME_Dream Dance/Bd5	4/4	4	136	○		:
DrPc	Elect	5376	ME_Dream Dance/Hh1	4/4	1	136	○		:
DrPc	Elect	5377	ME_Dream Dance/Hh2	4/4	4	136	○		:
DrPc	Elect	5378	ME_Dream Dance/Hh3	4/4	2	136	○		:
DrPc	Elect	5379	ME_Dream Dance/Hh4	4/4	4	136	○		"Analog T8 Kit"
DrPc	Elect	5380	ME_Dream Dance/Clp	4/4	4	136	○		"House Kit 1"
DrPc	Elect	5381	ME_Dream Dance/Pc1	4/4	4	136	○		"Percussion Kit"
DrPc	Elect	5382	ME_Dream Dance/Pc2	4/4	2	136	○		"Analog T8 Kit"
DrPc	Elect	5383	ME_Dream Dance/Pc3	4/4	4	136	○		:
DrPc	Elect	5384	FA_Dream Dance/Sdf	4/4	4	136	○		"House Kit 1"
DrPc	Elect	5385	MA1_Ibiza	4/4	2	135	○		:
DrPc	Elect	5386	MB1_Ibiza	4/4	2	135	○		:
DrPc	Elect	5387	MC1_Ibiza	4/4	2	135	○		:
DrPc	Elect	5388	MD1_Ibiza	4/4	2	135	○		:
DrPc	Elect	5389	IA1_Ibiza	4/4	8	135	○		:

Main Category	Sub Category	ARP No.	ARP Name	Time Signature	Length	Original Tempo	Accent	Random SFX	Voice Type
DrPc	Elect	5390	FA1_Ibiza	4/4	1	135	○		"House Kit 1"
DrPc	Elect	5391	FB1_Ibiza	4/4	1	135	○		:
DrPc	Elect	5392	FC1_Ibiza	4/4	2	135	○		:
DrPc	Elect	5393	MA2_Ibiza	4/4	2	135	○		"Dry Standard Kit"
DrPc	Elect	5394	FB2_Ibiza	4/4	1	135	○		"Dry Standard Kit" (PB Range=24)"
DrPc	Elect	5395	MA_Retro Pop	4/4	1	126	○		"House Kit 1"
DrPc	Elect	5396	MC_Retro Pop	4/4	2	126	○		:
DrPc	Elect	5397	FC_Retro Pop	4/4	1	126	○		:
DrPc	Elect	5398	MA_Euro Teck	4/4	2	140	○		"Tekno Kit"
DrPc	Elect	5399	MB_Euro Teck	4/4	2	140	○		:
DrPc	Elect	5400	MC_Euro Teck	4/4	2	140	○		:
DrPc	Elect	5401	MD_Euro Teck	4/4	2	140	○		:
DrPc	Elect	5402	ME_Euro Teck	4/4	2	140	○		:
DrPc	Elect	5403	MA_Disco House	4/4	4	126	○		"Acid Kit"
DrPc	Elect	5404	MB_Disco House	4/4	4	126	○		:
DrPc	Elect	5405	MC_Disco House	4/4	4	126	○		:
DrPc	Elect	5406	FA_Disco House	4/4	1	126	○		:
DrPc	Elect	5407	FB_Disco House	4/4	1	126	○		:
DrPc	Elect	5408	FC_Disco House	4/4	1	126	○		:
DrPc	Elect	5409	BA_Disco House	4/4	1	126	○		:
DrPc	Elect	5410	MA1_Club House	4/4	1	128	○		"House Kit 1"
DrPc	Elect	5411	MB1_Club House	4/4	1	128	○		:
DrPc	Elect	5412	MC1_Club House	4/4	1	128	○		:
DrPc	Elect	5413	MD1_Club House	4/4	1	128	○		:
DrPc	Elect	5414	IA1_Club House	4/4	2	128	○		:
DrPc	Elect	5415	FA1_Club House	4/4	1	128	○		:
DrPc	Elect	5416	FB1_Club House	4/4	1	128	○		:
DrPc	Elect	5417	FC1_Club House	4/4	2	128	○		:
DrPc	Elect	5418	MD2_Club House	4/4	1	128	○		"Hyper Standard Kit"
DrPc	Elect	5419	IA2_Club House	4/4	1	128	○		"House Kit 1"
DrPc	Elect	5420	FB2_Club House	4/4	1	128	○		"Hyper Standard Kit"
DrPc	Elect	5421	MA_House 1	4/4	2	123	○		"Analog T9 Kit"
DrPc	Elect	5422	MA_House 2	4/4	1	123	○		"Garage Kit"
DrPc	Elect	5423	MA_House 3	4/4	2	127	○		:
DrPc	Elect	5424	MA_House 4	4/4	2	130	○		"Hip Hop Kit 3"
DrPc	Elect	5425	MB_House 4	4/4	2	130	○		:
DrPc	Elect	5426	MC_House 4	4/4	2	130	○		:
DrPc	Elect	5427	MA_House 5	4/4	4	120	○		"House Kit 1"
DrPc	Elect	5428	MB_House 5	4/4	1	120	○		:
DrPc	Elect	5429	MC_House 5	4/4	1	120	○		:
DrPc	Elect	5430	MD_House 5	4/4	1	120	○		:
DrPc	Elect	5431	MA_House 6	4/4	1	120	○		:
DrPc	Elect	5432	MB_House 6	4/4	1	120	○		:
DrPc	Elect	5433	MC_House 6	4/4	1	120	○		:
DrPc	Elect	5434	MA_House 7	4/4	1	120	○		:
DrPc	Elect	5435	MB_House 7	4/4	1	120	○		:
DrPc	Elect	5436	MA_House 8	4/4	2	120	○		:
DrPc	Elect	5437	MA_House 9	4/4	4	120	○		:
DrPc	Elect	5438	MA_House 10	4/4	1	120	○		:
DrPc	Elect	5439	MB_House 10	4/4	1	120	○		:
DrPc	Elect	5440	MA_House 11	4/4	1	120	○		:
DrPc	Elect	5441	MB_House 11	4/4	1	120	○		:
DrPc	Elect	5442	MC_House 11	4/4	1	120	○		:
DrPc	Elect	5443	MA_House 12	4/4	2	120	○		:
DrPc	Elect	5444	MA_House 13	4/4	2	120	○		:
DrPc	Elect	5445	MA_House 14	4/4	1	123	○		:
DrPc	Elect	5446	MA_House 15	4/4	2	128	○		:
DrPc	Elect	5447	MA_Garage 1	4/4	2	130	○		"Garage Kit"
DrPc	Elect	5448	MA_Garage 2	4/4	2	127	○		"House Kit 1"
DrPc	Elect	5449	MB_Garage 2	4/4	2	127	○		:
DrPc	Elect	5450	MC_Garage 2	4/4	2	127	○		:
DrPc	Elect	5451	MD_Garage 2	4/4	2	127	○		:
DrPc	Elect	5452	IA_Garage 2/a	4/4	1	127	○		:
DrPc	Elect	5453	IA_Garage 2/b	4/4	1	127	○		:
DrPc	Elect	5454	FA_Garage 2	4/4	1	127	○		:
DrPc	Elect	5455	FC_Garage 2	4/4	2	127	○		:
DrPc	Elect	5456	MA_UK Garage 1	4/4	1	135	○		"Garage Kit"
DrPc	Elect	5457	MA_UK Garage 2	4/4	1	135	○		:
DrPc	Elect	5458	MA_UK Garage 3	4/4	1	138	○		:
DrPc	Elect	5459	MA_UK Garage 4	4/4	2	138	○		:
DrPc	Elect	5460	MA_UK Garage 5	4/4	1	138	○		:
DrPc	Elect	5461	MA_UK Garage 6	4/4	4	130	○		"House Kit 1"
DrPc	Elect	5462	MB_UK Garage 6	4/4	4	130	○		:
DrPc	Elect	5463	MC_UK Garage 6	4/4	4	130	○		:
DrPc	Elect	5464	MA_2 Step	4/4	2	120	○		:
DrPc	Jazz	5465	MA_AcousticJ						

Arpeggio Type List

Main Category	Sub Category	ARP No.	ARP Name	Time Signature	Length	Original Tempo	Accent	Random SFX	Voice Type
DrPc	Jazz	5473	MA1_Modern Jazz	4/4	16	218	○		*Power Standard Kit 1*
DrPc	Jazz	5474	MB1_Modern Jazz	4/4	16	218	○		:
DrPc	Jazz	5475	MC1_Modern Jazz	4/4	16	218	○		:
DrPc	Jazz	5476	FA1_Modern Jazz	4/4	1	218	○		:
DrPc	Jazz	5477	FB1_Modern Jazz	4/4	1	218	○		:
DrPc	Jazz	5478	FC1_Modern Jazz	4/4	1	218	○		:
DrPc	Jazz	5479	BA1_Modern Jazz	4/4	1	218	○		:
DrPc	Jazz	5480	MA2_Modern Jazz	4/4	16	218	○		*Pop Latin Kit*
DrPc	Jazz	5481	MB2_Modern Jazz	4/4	16	218	○		:
DrPc	Jazz	5482	MC2_Modern Jazz	4/4	16	218	○		:
DrPc	Jazz	5483	FA2_Modern Jazz	4/4	1	218	○		:
DrPc	Jazz	5484	FB2_Modern Jazz	4/4	1	218	○		:
DrPc	Jazz	5485	FC2_Modern Jazz	4/4	1	218	○		:
DrPc	Jazz	5486	BA2_Modern Jazz	4/4	1	218	○		:
DrPc	Jazz	5487	MA_Bebop	4/4	4	152	○		*Dry Standard Kit*
DrPc	Jazz	5488	MB_Bebop	4/4	4	152	○		:
DrPc	Jazz	5489	MA_R&R Shuffle	4/4	4	192	○		*Power Standard Kit 1*
DrPc	Jazz	5490	MB_R&R Shuffle	4/4	4	192	○		:
DrPc	Jazz	5491	MC_R&R Shuffle	4/4	4	192	○		:
DrPc	Jazz	5492	FA_R&R Shuffle	4/4	1	192	○		:
DrPc	Jazz	5493	FB_R&R Shuffle	4/4	1	192	○		:
DrPc	Jazz	5494	FC_R&R Shuffle	4/4	1	192	○		:
DrPc	Jazz	5495	BA_R&R Shuffle	4/4	1	192	○		:
DrPc	Jazz	5496	MA_ShuffleBlues	4/4	4	115	○		*Power Standard Kit 2*
DrPc	Jazz	5497	MB_ShuffleBlues	4/4	4	115	○		:
DrPc	Jazz	5498	MC_ShuffleBlues	4/4	4	115	○		:
DrPc	Jazz	5499	FA_ShuffleBlues	4/4	1	115	○		:
DrPc	Jazz	5500	FB_ShuffleBlues	4/4	1	115	○		:
DrPc	Jazz	5501	FC_ShuffleBlues	4/4	1	115	○		:
DrPc	Jazz	5502	BA_ShuffleBlues	4/4	1	115	○		:
DrPc	Jazz	5503	MA_Slow Blues 1	4/4	2	49	○		:
DrPc	Jazz	5504	MB_Slow Blues 1	4/4	2	49	○		:
DrPc	Jazz	5505	MC_Slow Blues 1	4/4	2	49	○		:
DrPc	Jazz	5506	FA_Slow Blues 1	4/4	1	49	○		:
DrPc	Jazz	5507	FB_Slow Blues 1	4/4	1	49	○		:
DrPc	Jazz	5508	FC_Slow Blues 1	4/4	1	49	○		:
DrPc	Jazz	5509	BA_Slow Blues 1	4/4	1	49	○		:
DrPc	Jazz	5510	MA_Slow Blues 2	4/4	4	72	○		*Modern Rock Kit*
DrPc	Jazz	5511	MB_Slow Blues 2	4/4	4	72	○		:
DrPc	Jazz	5512	MC_Slow Blues 2	4/4	4	72	○		:
DrPc	Jazz	5513	FA_Slow Blues 2	4/4	1	72	○		:
DrPc	Jazz	5514	FB_Slow Blues 2	4/4	1	72	○		:
DrPc	Jazz	5515	FC_Slow Blues 2	4/4	1	72	○		:
DrPc	Jazz	5516	BA_Slow Blues 2	4/4	1	72	○		:
DrPc	Jazz	5517	MA_Piano Boogie	4/4	8	160	○		*Power Standard Kit 2*
DrPc	Jazz	5518	MB_Piano Boogie	4/4	4	160	○		:
DrPc	Jazz	5519	MC_Piano Boogie	4/4	4	160	○		:
DrPc	Jazz	5520	FA_Piano Boogie	4/4	1	160	○		:
DrPc	Jazz	5521	FB_Piano Boogie	4/4	1	160	○		:
DrPc	Jazz	5522	FC_Piano Boogie	4/4	1	160	○		:
DrPc	Jazz	5523	BA_Piano Boogie	4/4	1	160	○		:
DrPc	World	5524	MA_ReggaeShuffle	4/4	4	90	○		*Power Standard Kit 1*
DrPc	World	5525	MB_ReggaeShuffle	4/4	4	90	○		:
DrPc	World	5526	MC_ReggaeShuffle	4/4	4	90	○		:
DrPc	World	5527	FA_ReggaeShuffle	4/4	1	90	○		:
DrPc	World	5528	FB_ReggaeShuffle	4/4	1	90	○		:
DrPc	World	5529	FC_ReggaeShuffle	4/4	1	90	○		:
DrPc	World	5530	BA_ReggaeShuffle	4/4	1	90	○		:
DrPc	World	5531	MA_Jumbo Reggae	4/4	4	100	○		*Trance Kit*
DrPc	World	5532	MB_Jumbo Reggae	4/4	4	100	○		:
DrPc	World	5533	MC_Jumbo Reggae	4/4	4	100	○		:
DrPc	World	5534	FA_Jumbo Reggae	4/4	1	100	○		:
DrPc	World	5535	FB_Jumbo Reggae	4/4	1	100	○		:
DrPc	World	5536	FC_Jumbo Reggae	4/4	1	100	○		:
DrPc	World	5537	BA_Jumbo Reggae	4/4	1	100	○		:
DrPc	World	5538	MA1_Reggae 1	4/4	4	102	○		*Dry Standard Kit*
DrPc	World	5539	MB1_Reggae 1	4/4	4	102	○		:
DrPc	World	5540	MC1_Reggae 1	4/4	4	80	○		:
DrPc	World	5541	MD1_Reggae 1	4/4	4	90	○		:
DrPc	World	5542	IA1_Reggae 1	4/4	4	102	○		:
DrPc	World	5543	FA1_Reggae 1	4/4	1	96	○		:
DrPc	World	5544	FB1_Reggae 1	4/4	1	102	○		:
DrPc	World	5545	FC1_Reggae 1	4/4	4	96	○		:
DrPc	World	5546	MA2_Reggae 1	4/4	4	102	○		*Percussion Kit*
DrPc	World	5547	MB2_Reggae 1	4/4	4	102	○		:
DrPc	World	5548	MC2_Reggae 1	4/4	4	80	○		:
DrPc	World	5549	MD2_Reggae 1	4/4	4	90	○		:
DrPc	World	5550	IA2_Reggae 1	4/4	4	102	○		:
DrPc	World	5551	FC2_Reggae 1	4/4	4	96	○		:
DrPc	World	5552	MA_Reggae 2	4/4	2	92	○		*Dry Standard Kit*
DrPc	World	5553	MB_Reggae 2	4/4	2	92	○		:
DrPc	World	5554	MC_Reggae 2	4/4	2	92	○		:
DrPc	World	5555	MD_Reggae 2	4/4	2	92	○		:

Main Category	Sub Category	ARP No.	ARP Name	Time Signature	Length	Original Tempo	Accent	Random SFX	Voice Type
DrPc	World	5556	IA_Reggae 2/a	4/4	1	92	○		*Dry Standard Kit*
DrPc	World	5557	IA_Reggae 2/b	4/4	1	92	○		:
DrPc	World	5558	FA_Reggae 2	4/4	1	92	○		:
DrPc	World	5559	FB_Reggae 2	4/4	1	92	○		:
DrPc	World	5560	FC_Reggae 2	4/4	1	92	○		:
DrPc	World	5561	MA1_Salsa 1	4/4	4	177	○		*Power Standard Kit 1*
DrPc	World	5562	MB1_Salsa 1	4/4	4	177	○		:
DrPc	World	5563	MC1_Salsa 1	4/4	4	177	○		:
DrPc	World	5564	FA1_Salsa 1	4/4	1	177	○		:
DrPc	World	5565	FB1_Salsa 1	4/4	1	177	○		:
DrPc	World	5566	FC1_Salsa 1	4/4	1	177	○		:
DrPc	World	5567	BA1_Salsa 1	4/4	1	177	○		:
DrPc	World	5568	MA2_Salsa 1	4/4	4	177	○		*Pop Latin Kit*
DrPc	World	5569	MB2_Salsa 1	4/4	4	177	○		:
DrPc	World	5570	MC2_Salsa 1	4/4	4	177	○		:
DrPc	World	5571	FA2_Salsa 1	4/4	1	177	○		:
DrPc	World	5572	FB2_Salsa 1	4/4	1	177	○		:
DrPc	World	5573	FC2_Salsa 1	4/4	1	177	○		:
DrPc	World	5574	BA2_Salsa 1	4/4	1	177	○		:
DrPc	World	5575	MA1_Salsa 2	4/4	2	123	○		*Dry Standard Kit*
DrPc	World	5576	MB1_Salsa 2	4/4	2	123	○		:
DrPc	World	5577	MC1_Salsa 2	4/4	2	123	○		:
DrPc	World	5578	MD1_Salsa 2	4/4	4	123	○		:
DrPc	World	5579	IA1_Salsa 2/a	4/4	2	123	○		:
DrPc	World	5580	IA1_Salsa 2/b	4/4	2	123	○		:
DrPc	World	5581	FA1_Salsa 2	4/4	1	123	○		:
DrPc	World	5582	FB1_Salsa 2	4/4	1	123	○		:
DrPc	World	5583	FC1_Salsa 2	4/4	2	123	○		:
DrPc	World	5584	MA2_Salsa 2	4/4	4	123	○		*Pop Latin Kit*
DrPc	World	5585	MB2_Salsa 2	4/4	4	123	○		:
DrPc	World	5586	MC2_Salsa 2	4/4	4	123	○		:
DrPc	World	5587	MD2_Salsa 2	4/4	4	123	○		:
DrPc	World	5588	IA2_Salsa 2	4/4	4	123	○		:
DrPc	World	5589	FA2_Salsa 2	4/4	1	123	○		:
DrPc	World	5590	FB2_Salsa 2	4/4	1	123	○		:
DrPc	World	5591	FC2_Salsa 2	4/4	2	123	○		:
DrPc	World	5592	MA1_AfroCuban	4/4	4	200	○		*Power Standard Kit 1*
DrPc	World	5593	MB1_AfroCuban	4/4	4	200	○		:
DrPc	World	5594	MC1_AfroCuban	4/4	4	200	○		:
DrPc	World	5595	FA1_AfroCuban	4/4	1	200	○		:
DrPc	World	5596	FB1_AfroCuban	4/4	1	200	○		:
DrPc	World	5597	FC1_AfroCuban	4/4	1	200	○		:
DrPc	World	5598	BA1_AfroCuban	4/4	1	200	○		:
DrPc	World	5599	MA2_AfroCuban	4/4	4	200	○		*Pop Latin Kit*
DrPc	World	5600	MB2_AfroCuban	4/4	4	200	○		:
DrPc	World	5601	MC2_AfroCuban	4/4	4	200	○		:
DrPc	World	5602	FA2_AfroCuban	4/4	1	200	○		:
DrPc	World	5603	FB2_AfroCuban	4/4	1	200	○		:
DrPc	World	5604	FC2_AfroCuban	4/4	1	200	○		:
DrPc	World	5605	BA2_AfroCuban	4/4	1	200	○		:
DrPc	World	5606	MA1_Montuno	4/4	2	100	○		*Dry Standard Kit*
DrPc	World	5607	MB1_Montuno	4/4	2	100	○		:
DrPc	World	5608	MC1_Montuno	4/4	2	100	○		:
DrPc	World	5609	MD1_Montuno	4/4	2	100	○		:
DrPc	World	5610	IA1_Montuno	4/4	2	100	○		:
DrPc	World	5611	FA1_Montuno	4/4	1	100	○		:
DrPc	World	5612	FB1_Montuno	4/4	1	100	○		:
DrPc	World	5613	FC1_Montuno	4/4	2	100	○		:
DrPc	World	5614	MA2_Montuno	4/4	4	100	○		*Latin Percussion Kit*
DrPc	World	5615	MB2_Montuno	4/4	4	100	○		:
DrPc	World	5616	MC2_Montuno	4/4	4	100	○		:
DrPc	World	5617	MD2_Montuno	4/4	4	100	○		:
DrPc	World	5618	IA2_Montuno	4/4	4	100	○		:
DrPc	World	5619	FA2_Montuno	4/4	1	100	○		:
DrPc	World	5620	FB2_Montuno	4/4	1	100	○		:
DrPc	World	5621	FC2_Montuno	4/4	4	100	○		:
DrPc	World	5622	MA1_Brazil Samba	4/4	4	96	○		*Power Standard Kit 1*
DrPc	World	5623	MB1_Brazil Samba	4/4	4	96	○		:
DrPc	World	5624	MC1_Brazil Samba	4/4	4	96	○		:
DrPc	World	5625	FA1_Brazil Samba	4/4	1	96	○		:
DrPc	World	5626	FB1_Brazil Samba	4/4	1	96	○		:
DrPc	World	5627	FC1_Brazil Samba	4/4	1	96	○		:
DrPc	World	5628	BA1_Brazil Samba	4/4	1	96	○		:
DrPc	World	5629	MA2_Brazil Samba	4/4	4	96	○		*Pop Latin Kit*
DrPc	World	5630	MB2_Brazil Samba	4/4	4	96	○		:
DrPc	World	5631	MC2_Brazil Samba	4/4	4	96	○		:
DrPc	World	5632	FA2_Brazil Samba	4/4	1	96	○		:
DrPc	World	5633	FB2_Brazil Samba	4/4	1	96	○		:

Arpeggio Type List

Main Category	Sub Category	ARP No.	ARP Name	Time Signature	Length	Original Tempo	Accent	Random SFX	Voice Type
DrPc	World	5639	MD_Samba	4/4	4	120	○		"Dry Standard Kit"
DrPc	World	5640	IA_Samba	4/4	2	120	○		:
DrPc	World	5641	FA_Samba	4/4	1	120	○		:
DrPc	World	5642	FB_Samba	4/4	1	120	○		:
DrPc	World	5643	FC_Samba	4/4	2	120	○		:
DrPc	World	5644	MA_Bomba	4/4	4	99	○		"Pop Latin Kit"
DrPc	World	5645	MB_Bomba	4/4	4	99	○		:
DrPc	World	5646	MC_Bomba	4/4	4	99	○		:
DrPc	World	5647	FA_Bomba	4/4	1	99	○		:
DrPc	World	5648	FB_Bomba	4/4	1	99	○		:
DrPc	World	5649	FC_Bomba	4/4	1	99	○		:
DrPc	World	5650	BA_Bomba	4/4	1	99	○		:
DrPc	World	5651	MA1_Bossa	4/4	4	124	○		"Brush Kit"
DrPc	World	5652	MB1_Bossa	4/4	4	124	○		:
DrPc	World	5653	MC1_Bossa	4/4	4	124	○		:
DrPc	World	5654	FA1_Bossa	4/4	1	124	○		:
DrPc	World	5655	FB1_Bossa	4/4	1	124	○		:
DrPc	World	5656	FC1_Bossa	4/4	1	124	○		:
DrPc	World	5657	BA1_Bossa	4/4	1	124	○		:
DrPc	World	5658	MA2_Bossa	4/4	4	124	○		:
DrPc	World	5659	MB2_Bossa	4/4	4	124	○		:
DrPc	World	5660	MC2_Bossa	4/4	4	124	○		:
DrPc	World	5661	FA2_Bossa	4/4	1	124	○		:
DrPc	World	5662	FB2_Bossa	4/4	1	124	○		:
DrPc	World	5663	FC2_Bossa	4/4	1	124	○		:
DrPc	World	5664	BA2_Bossa	4/4	1	124	○		:
DrPc	World	5665	MA_Merengue	4/4	4	130	○		"Pop Latin Kit"
DrPc	World	5666	MB_Merengue	4/4	4	130	○		:
DrPc	World	5667	MC_Merengue	4/4	4	130	○		:
DrPc	World	5668	FA_Merengue	4/4	1	130	○		:
DrPc	World	5669	FB_Merengue	4/4	1	130	○		:
DrPc	World	5670	FC_Merengue	4/4	1	130	○		:
DrPc	World	5671	BA_Merengue	4/4	1	130	○		:
DrPc	World	5672	MA1_RumbaFlamenc	4/4	4	106	○		"Power Standard Kit 1"
DrPc	World	5673	MB1_RumbaFlamenc	4/4	4	106	○		:
DrPc	World	5674	MC1_RumbaFlamenc	4/4	4	106	○		:
DrPc	World	5675	FA1_RumbaFlamenc	4/4	1	106	○		:
DrPc	World	5676	FB1_RumbaFlamenc	4/4	1	106	○		:
DrPc	World	5677	FC1_RumbaFlamenc	4/4	1	106	○		:
DrPc	World	5678	BA1_RumbaFlamenc	4/4	1	106	○		:
DrPc	World	5679	MA2_RumbaFlamenc	4/4	4	106	○		"Pop Latin Kit"
DrPc	World	5680	MB2_RumbaFlamenc	4/4	4	106	○		:
DrPc	World	5681	MC2_RumbaFlamenc	4/4	4	106	○		:
DrPc	World	5682	FA2_RumbaFlamenc	4/4	1	106	○		:
DrPc	World	5683	FB2_RumbaFlamenc	4/4	1	106	○		:
DrPc	World	5684	FC2_RumbaFlamenc	4/4	1	106	○		:
DrPc	World	5685	BA2_RumbaFlamenc	4/4	1	106	○		:
DrPc	World	5686	MA_Guaguanco	4/4	4	120	○		:
DrPc	World	5687	MB_Guaguanco	4/4	4	120	○		:
DrPc	World	5688	MC_Guaguanco	4/4	4	120	○		:
DrPc	World	5689	FA_Guaguanco	4/4	1	120	○		:
DrPc	World	5690	FB_Guaguanco	4/4	1	120	○		:
DrPc	World	5691	FC_Guaguanco	4/4	1	120	○		:
DrPc	World	5692	BA_Guaguanco	4/4	1	120	○		:
DrPc	World	5693	MA_Latin	4/4	4	120	○		"Latin Percussion Kit"
DrPc	World	5694	MB_Latin	4/4	4	120	○		:
DrPc	World	5695	MC_Latin	4/4	4	120	○		:
DrPc	World	5696	MD_Latin	4/4	4	120	○		:
DrPc	World	5697	ME_Latin	4/4	4	120	○		:
DrPc	World	5698	MA_Latin Rock	4/4	2	120	○		"Dry Standard Kit"
DrPc	World	5699	MB_Latin Rock	4/4	2	120	○		:
DrPc	World	5700	MC_Latin Rock	4/4	2	120	○		:
DrPc	World	5701	MD_Latin Rock	4/4	4	120	○		:
DrPc	World	5702	IA_Latin Rock	4/4	2	120	○		:
DrPc	World	5703	FA_Latin Rock	4/4	1	120	○		:
DrPc	World	5704	FB_Latin Rock	4/4	1	120	○		:
DrPc	World	5705	FC_Latin Rock	4/4	1	120	○		:
DrPc	World	5706	MA1_Disco Latin	4/4	4	100	○		:
DrPc	World	5707	MB1_Disco Latin	4/4	4	100	○		:
DrPc	World	5708	MC1_Disco Latin	4/4	4	100	○		:
DrPc	World	5709	FA1_Disco Latin	4/4	1	100	○		:
DrPc	World	5710	FB1_Disco Latin	4/4	1	100	○		:
DrPc	World	5711	FC1_Disco Latin	4/4	1	100	○		:
DrPc	World	5712	BA1_Disco Latin	4/4	1	100	○		:
DrPc	World	5713	MA2_Disco Latin	4/4	4	100	○		"Latin Percussion Kit"
DrPc	World	5714	MB2_Disco Latin	4/4	4	100	○		:
DrPc	World	5715	MC2_Disco Latin	4/4	4	100	○		:
DrPc	World	5716	FA2_Disco Latin	4/4	1	100	○		:
DrPc	World	5717	FB2_Disco Latin	4/4	1	100	○		:
DrPc	World	5718	FC2_Disco Latin	4/4	1	100	○		:
DrPc	World	5719	BA2_Disco Latin	4/4	1	100	○		:
DrPc	World	5720	MA_Latin House	4/4	4	138	○		"House Kit 1"
DrPc	World	5721	FB_Latin House	4/4	4	138	○		:

Main Category	Sub Category	ARP No.	ARP Name	Time Signature	Length	Original Tempo	Accent	Random SFX	Voice Type
DrPc	World	5722	FC_Latin House	4/4	4	138	○		"House Kit 1"
DrPc	World	5723	MA_Spanish Pop	4/4	2	120	○		"Hyper Standard Kit"
DrPc	World	5724	MB_Spanish Pop	4/4	2	120	○		:
DrPc	World	5725	MC_Spanish Pop	4/4	2	120	○		:
DrPc	World	5726	MD_Spanish Pop	4/4	2	120	○		:
DrPc	World	5727	IA_Spanish Pop/a	4/4	1	120	○		:
DrPc	World	5728	IA_Spanish Pop/b	4/4	1	120	○		:
DrPc	World	5729	FA_Spanish Pop	4/4	1	120	○		:
DrPc	World	5730	FB_Spanish Pop	4/4	1	120	○		:
DrPc	World	5731	FC_Spanish Pop	4/4	1	120	○		:
DrPc	World	5732	MA_Irish Hymn	3/4	4	70	○		"Power Standard Kit 2"
DrPc	World	5733	MB_Irish Hymn	3/4	4	70	○		:
DrPc	World	5734	MC_Irish Hymn	3/4	4	70	○		:
DrPc	World	5735	FA_Irish Hymn	3/4	1	70	○		:
DrPc	World	5736	FB_Irish Hymn	3/4	1	70	○		:
DrPc	World	5737	FC_Irish Hymn	3/4	1	70	○		:
DrPc	World	5738	BA_Irish Hymn	3/4	1	70	○		:
DrPc	World	5739	MA1_Turkish Pop	4/4	4	101	○		"Arabic Mixed Kit"
DrPc	World	5740	MB1_Turkish Pop	4/4	4	101	○		:
DrPc	World	5741	MC1_Turkish Pop	4/4	4	101	○		:
DrPc	World	5742	MD1_Turkish Pop	4/4	4	101	○		:
DrPc	World	5743	FA1_Turkish Pop	4/4	1	101	○		:
DrPc	World	5744	FB1_Turkish Pop	4/4	1	101	○		:
DrPc	World	5745	FC1_Turkish Pop	4/4	1	101	○		:
DrPc	World	5746	FD1_Turkish Pop	4/4	1	101	○		:
DrPc	World	5747	MA2_Turkish Pop	4/4	4	101	○		"Hip Hop Kit 1"
DrPc	World	5748	MB2_Turkish Pop	4/4	4	101	○		:
DrPc	World	5749	MC2_Turkish Pop	4/4	4	101	○		:
DrPc	World	5750	MD2_Turkish Pop	4/4	4	101	○		:
DrPc	World	5751	FA2_Turkish Pop	4/4	1	101	○		:
DrPc	World	5752	FB2_Turkish Pop	4/4	1	101	○		:
DrPc	World	5753	FC2_Turkish Pop	4/4	1	101	○		:
DrPc	World	5754	FD2_Turkish Pop	4/4	1	101	○		:
DrPc	World	5755	MA1_TurkishDance	4/4	4	130	○		"Arabic Mixed Kit"
DrPc	World	5756	MB1_TurkishDance	4/4	4	130	○		:
DrPc	World	5757	MC1_TurkishDance	4/4	4	130	○		:
DrPc	World	5758	MD1_TurkishDance	4/4	4	130	○		:
DrPc	World	5759	FA1_TurkishDance	4/4	1	130	○		:
DrPc	World	5760	FB1_TurkishDance	4/4	1	130	○		:
DrPc	World	5761	FC1_TurkishDance	4/4	1	130	○		:
DrPc	World	5762	FD1_TurkishDance	4/4	1	130	○		:
DrPc	World	5763	MA2_TurkishDance	4/4	4	130	○		"Hip Hop Kit 1"
DrPc	World	5764	MB2_TurkishDance	4/4	4	130	○		:
DrPc	World	5765	MC2_TurkishDance	4/4	4	130	○		:
DrPc	World	5766	MD2_TurkishDance	4/4	4	130	○		:
DrPc	World	5767	FA2_TurkishDance	4/4	1	130	○		:
DrPc	World	5768	FB2_TurkishDance	4/4	1	130	○		:
DrPc	World	5769	FC2_TurkishDance	4/4	1	130	○		:
DrPc	World	5770	FD2_TurkishDance	4/4	1	130	○		:
DrPc	World	5771	MA1_Turkish	4/4	2	105	○		"Arabic Mixed Kit"
DrPc	World	5772	MB1_Turkish	4/4	2	105	○		:
DrPc	World	5773	MC1_Turkish	9/8	2	125	○		:
DrPc	World	5774	MD1_Turkish	9/8	2	125	○		:
DrPc	World	5775	ME1_Turkish	4/4	2	105	○		:
DrPc	World	5776	MA_Turkish	4/4	2	105	○		:
DrPc	World	5777	IA1_Turkish/a	4/4	1	86	○		:
DrPc	World	5778	IA1_Turkish/b	4/4	1	86	○		:
DrPc	World	5779	FA1_Turkish	4/4	1	120	○		:
DrPc	World	5780	MA2_Turkish	4/4	2	105	○		:
DrPc	World	5781	MB2_Turkish	4/4	2	105	○		:
DrPc	World	5782	MC2_Turkish	9/8	2	125	○		:
DrPc	World	5783	MD2_Turkish	9/8	2	125	○		:
DrPc	World	5784	ME2_Turkish	4/4	2	105	○		:
DrPc	World	5785	MF2_Turkish	4/4	2	105	○		:
DrPc	World	5786	IA_Turkish/a	4/4	1	86	○		:
DrPc	World	5787	IA_Turkish/b	4/4	1	86	○		:
DrPc	World	5788	FA2_Turkish	4/4	1	120	○		:
DrPc	Genrl	5789	MA_Orchestra	4/4	4	102	○		"Orchestra Kit"
DrPc	Genrl	5790	MC_Orchestra	4/4	8	102	○		:
DrPc	Genrl	5791	MD_Orchestra	4/4	4	102	○		:
DrPc	Genrl	5792	FA_Orchestra	4/4	1	102	○		:
DrPc	Genrl	5793	8Beat Slice1	4/4	1	135	○		"Power Standard Kit 1"
DrPc	Genrl	5794	8Beat Slice2	4/4	1	135	○		:
DrPc	Genrl	5795	8Beat Slice3	4/4	1	135	○		:
DrPc	Genrl	5796	16BeatSlice1	4/4	1	135	○		:
DrPc	Genrl	5797	16BeatSlice2	4/4	1	135	○		:
DrPc	Genrl	5798	1Bar Slice	4/4	1	135	○		:
DrPc	Genrl	5799	1BarRndSlice	4/4	1	135	○		:
DrPc	Genrl	5800	Roll 1	4/4	1				

Arpeggio Type List

Main Category	Sub Category	ARP No.	ARP Name	Time Signature	Length	Original Tempo	Accent	Random SFX	Voice Type
Seq	Rock	5805	MA_AlternaRock2_ES	4/4	4	100			Syn Comp/Lead
Seq	Rock	5806	MB_AlternaRock2_ES	4/4	4	100			:
Seq	Rock	5807	MC_AlternaRock2_ES	4/4	4	100			:
Seq	Rock	5808	FA_AlternaRock2_ES	4/4	1	100			:
Seq	Rock	5809	FB_AlternaRock2_ES	4/4	1	100			:
Seq	Rock	5810	FC_AlternaRock2_ES	4/4	1	100			:
Seq	Rock	5811	BA_AlternaRock2_ES	4/4	2	100			:
Seq	R&B	5812	MB_R&B Disco_ES	4/4	2	110			:
Seq	R&B	5813	MC_R&B Disco_ES	4/4	2	110			:
Seq	R&B	5814	MA_Chart R&B_XS	4/4	4	130			:
Seq	R&B	5815	MB_Chart R&B_XS	4/4	4	130			:
Seq	R&B	5816	MC_Chart R&B_XS	4/4	4	130			:
Seq	R&B	5817	FA_Chart R&B_XS	4/4	1	130			:
Seq	R&B	5818	FB_Chart R&B_XS	4/4	1	130			:
Seq	R&B	5819	FC_Chart R&B_XS	4/4	1	130			:
Seq	R&B	5820	BA_Chart R&B_XS	4/4	1	130			:
Seq	R&B	5821	MC_New R&B 3_ES	4/4	2	90			:
Seq	R&B	5822	MD_New R&B 3	4/4	2	90			:
Seq	R&B	5823	FC_New R&B 3_ES	4/4	2	90			:
Seq	R&B	5824	MA_2BZ4U	4/4	2	75			:
Seq	R&B	5825	MB_2BZ4U	4/4	2	75			:
Seq	R&B	5826	MC_2BZ4U	4/4	2	75			:
Seq	R&B	5827	MD_2BZ4U	4/4	2	75			:
Seq	R&B	5828	MA_PopRally	4/4	4	75			:
Seq	R&B	5829	MB_PopRally	4/4	4	75			:
Seq	R&B	5830	MC_Hip Hop 3_ES	4/4	2	104			:
Seq	R&B	5831	MD_Hip Hop 3	4/4	2	104			:
Seq	R&B	5832	FB_Hip Hop 3	4/4	1	104			:
Seq	R&B	5833	MA_Hip Rock 2_XS	4/4	4	132			:
Seq	R&B	5834	MB_Hip Rock 2_XS	4/4	4	132			:
Seq	R&B	5835	MC_Hip Rock 2_XS	4/4	4	132			:
Seq	R&B	5836	FA_Hip Rock 2_XS	4/4	1	132			:
Seq	R&B	5837	FB_Hip Rock 2_XS	4/4	1	132			:
Seq	R&B	5838	FC_Hip Rock 2_XS	4/4	1	132			:
Seq	Elect	5839	MA1_Ambient 1_ES	4/4	4	102			:
Seq	Elect	5840	MB1_Ambient 1_ES	4/4	4	102			:
Seq	Elect	5841	MC1_Ambient 1_ES	4/4	4	102			:
Seq	Elect	5842	FA1_Ambient 1_ES	4/4	1	102			:
Seq	Elect	5843	FB1_Ambient 1_ES	4/4	1	102			:
Seq	Elect	5844	FC1_Ambient 1_ES	4/4	1	102			:
Seq	Elect	5845	BA1_Ambient 1_ES	4/4	1	102			:
Seq	Elect	5846	MB2_Ambient 1_ES	4/4	4	102			:
Seq	Elect	5847	MC2_Ambient 1_ES	4/4	4	102			:
Seq	Elect	5848	FB2_Ambient 1_ES	4/4	1	102			:
Seq	Elect	5849	FC2_Ambient 1_ES	4/4	1	102			:
Seq	Elect	5850	BA2_Ambient 1_ES	4/4	1	102			:
Seq	Elect	5851	MA1_Ambient 2_XS	4/4	4	111			:
Seq	Elect	5852	MB1_Ambient 2_XS	4/4	2	111			:
Seq	Elect	5853	MC1_Ambient 2_XS	4/4	4	111			:
Seq	Elect	5854	FA1_Ambient 2_XS	4/4	8	111			:
Seq	Elect	5855	FC1_Ambient 2_XS	4/4	1	111			:
Seq	Elect	5856	MA2_Ambient 2_XS	4/4	4	111			:
Seq	Elect	5857	MC2_Ambient 2_XS	4/4	4	111			:
Seq	Elect	5858	FA2_Ambient 2_XS	4/4	1	111			:
Seq	Elect	5859	FB2_Ambient 2_XS	4/4	8	111			:
Seq	Elect	5860	FC2_Ambient 2_XS	4/4	1	111			:
Seq	Elect	5861	BA2_Ambient 2_XS	4/4	2	111			:
Seq	Elect	5862	MA1_Ambient 2_ES	4/4	4	111			:
Seq	Elect	5863	MB1_Ambient 2_ES	4/4	2	111			:
Seq	Elect	5864	MC1_Ambient 2_ES	4/4	4	111			:
Seq	Elect	5865	FA1_Ambient 2_ES	4/4	8	111			:
Seq	Elect	5866	FC1_Ambient 2_ES	4/4	1	111			:
Seq	Elect	5867	MA2_Ambient 2_ES	4/4	4	111			:
Seq	Elect	5868	MC2_Ambient 2_ES	4/4	4	111			:
Seq	Elect	5869	FA2_Ambient 2_ES	4/4	1	111			:
Seq	Elect	5870	FB2_Ambient 2_ES	4/4	8	111			:
Seq	Elect	5871	FC2_Ambient 2_ES	4/4	1	111			:
Seq	Elect	5872	BA2_Ambient 2_ES	4/4	2	111			:
Seq	Elect	5873	MC_Chill Out	4/4	4	79			:
Seq	Elect	5874	MD_Chill Out	4/4	2	79			:
Seq	Elect	5875	FB_Chill Out	4/4	1	79			:
Seq	Elect	5876	MA_Synth Pop	4/4	1	90			:
Seq	Elect	5877	MB_Synth Pop	4/4	1	90			:
Seq	Elect	5878	MD_Synth Pop	4/4	1	90			:
Seq	Elect	5879	IA_Synth Pop	4/4	1	90			:
Seq	Elect	5880	FC_Synth Pop	4/4	1	90			:
Seq	Elect	5881	MA_Big Beat 1_ES	4/4	4	115			:
Seq	Elect	5882	MB_Big Beat 1_ES	4/4	4	115			:
Seq	Elect	5883	MC_Big Beat 1_ES	4/4	4	115			:
Seq	Elect	5884	FA_Big Beat 1_ES	4/4	1	115			:
Seq	Elect	5885	FB_Big Beat 1_ES	4/4	1	115			:
Seq	Elect	5886	FC_Big Beat 1_ES	4/4	1	115			:
Seq	Elect	5887	BA_Big Beat 1_ES	4/4	1	115			:

Main Category	Sub Category	ARP No.	ARP Name	Time Signature	Length	Original Tempo	Accent	Random SFX	Voice Type
Seq	Elect	5888	MA_Big Step1_ES	4/4	2	116			Syn Comp/Lead
Seq	Elect	5889	MA_Big Step2_ES	4/4	1	116			:
Seq	Elect	5890	MA_Big Step3_ES	4/4	2	116			:
Seq	Elect	5891	MA_Big Step4_ES	4/4	1	116			:
Seq	Elect	5892	MA_Big Step5_ES	4/4	1	116			:
Seq	Elect	5893	MA_Breakbeats 1_ES	4/4	4	115			:
Seq	Elect	5894	MB_Breakbeats 1_ES	4/4	4	115			:
Seq	Elect	5895	MC_Breakbeats 1_ES	4/4	2	115			:
Seq	Elect	5896	FA_Breakbeats 1_ES	4/4	1	115			:
Seq	Elect	5897	FB_Breakbeats 1_ES	4/4	1	115			:
Seq	Elect	5898	FC_Breakbeats 1_ES	4/4	1	115			:
Seq	Elect	5899	BA_Breakbeats 1_ES	4/4	1	115			:
Seq	Elect	5900	MA_Breakbeats 2_ES	4/4	4	88			:
Seq	Elect	5901	MB_Breakbeats 2_ES	4/4	4	88			:
Seq	Elect	5902	MC_Breakbeats 2_ES	4/4	4	88			:
Seq	Elect	5903	FA_Breakbeats 2_ES	4/4	1	88			:
Seq	Elect	5904	FB_Breakbeats 2_ES	4/4	1	88			:
Seq	Elect	5905	FC_Breakbeats 2_ES	4/4	1	88			:
Seq	Elect	5906	BA_Breakbeats 2_ES	4/4	1	88			:
Seq	Elect	5907	MA1_Trance 2_XS	4/4	8	135			:
Seq	Elect	5908	MB1_Trance 2_XS	4/4	8	135			:
Seq	Elect	5909	MC1_Trance 2_XS	4/4	8	135			:
Seq	Elect	5910	FA1_Trance 2_XS	4/4	1	135			:
Seq	Elect	5911	FB1_Trance 2_XS	4/4	8	135			:
Seq	Elect	5912	FC1_Trance 2_XS	4/4	1	135			:
Seq	Elect	5913	BA1_Trance 2_XS	4/4	1	135			:
Seq	Elect	5914	MA2_Trance 2_XS	4/4	8	135			:
Seq	Elect	5915	MB2_Trance 2_XS	4/4	8	135			:
Seq	Elect	5916	MC2_Trance 2_XS	4/4	8	135			:
Seq	Elect	5917	FA2_Trance 2_XS	4/4	1	135			:
Seq	Elect	5918	FB2_Trance 2_XS	4/4	8	135			:
Seq	Elect	5919	FC2_Trance 2_XS	4/4	1	135			:
Seq	Elect	5920	BA2_Trance 2_XS	4/4	1	135			:
Seq	Elect	5921	MA1_Trance 2_ES	4/4	8	135			:
Seq	Elect	5922	MB1_Trance 2_ES	4/4	8	135			:
Seq	Elect	5923	MC1_Trance 2_ES	4/4	8	135			:
Seq	Elect	5924	FA1_Trance 2_ES	4/4	1	135			:
Seq	Elect	5925	FB1_Trance 2_ES	4/4	8	135			:
Seq	Elect	5926	BA1_Trance 2_ES	4/4	1	135			:
Seq	Elect	5927	MA2_Trance 2_ES	4/4	8	135			:
Seq	Elect	5928	MB2_Trance 2_ES	4/4	8	135			:
Seq	Elect	5929	MC2_Trance 2_ES	4/4	8	135			:
Seq	Elect	5930	FA2_Trance 2_ES	4/4	1	135			:
Seq	Elect	5931	FB2_Trance 2_ES	4/4	8	135			:
Seq	Elect	5932	FC2_Trance 2_ES	4/4	1	135			:
Seq	Elect	5933	BA2_Trance 2_ES	4/4	1	135			:
Seq	Elect	5934	MA_Trance 3_XS	4/4	2	140			:
Seq	Elect	5935	MB_Trance 3_XS	4/4	2	140			:
Seq	Elect	5936	MC_Trance 3_XS	4/4	3	140			:
Seq	Elect	5937	FA_Trance 3_XS	4/4	2	140			:
Seq	Elect	5938	FB_Trance 3_XS	4/4	2	140			:
Seq	Elect	5939	FC_Trance 3_XS	4/4	4	140			:
Seq	Elect	5940	BA_Trance 3_XS	4/4	1	140			:
Seq	Elect	5941	MA_Trance 3_ES	4/4	2	140			:
Seq	Elect	5942	MB_Trance 3_ES	4/4	2	140			:
Seq	Elect	5943	MC_Trance 3_ES	4/4	3	140			:
Seq	Elect	5944	FA_Trance 3_ES	4/4	2	140			:
Seq	Elect	5945	FB_Trance 3_ES	4/4	2	140			:
Seq	Elect	5946	FC_Trance 3_ES	4/4	4	140			:
Seq	Elect	5947	BA_Trance 3_ES	4/4	1	140			:
Seq	Elect	5948	MA1_Trance 5	4/4	1	140			:
Seq	Elect	5949	MA2_Trance 5	4/4	4	140			:
Seq	Elect	5950	MD2_Trance 5	4/4	4	140			:
Seq	Elect	5951	IA3_Trance 5	4/4	1	140			:
Seq	Elect	5952	FC3_Trance 5	4/4	1	140			:
Seq	Elect	5953	MB4_Trance 5	4/4	4	140			:
Seq	Elect	5954	FA4_Trance 5	4/4	4	140			:
Seq	Elect	5955	FA5_Trance 5	4/4	4	140			:
Seq	Elect	5956	FC5_Trance 5	4/4	1	140			:
Seq	Elect	5957	MC6_Trance 5	4/4	4	140			:
Seq	Elect	5958	MA_PsycheSeq1_ES	4/4	4	140			:
Seq	Elect	5959	MA_PsycheSeq2_ES	4/4	1	140			:
Seq	Elect	5960	MA_PsycheSeq3_ES	4/4	2	140			:
Seq	Elect	5961	MA_PsycheSeq4_ES	4/4	4	140			:
Seq	Elect	5962	MA_PsycheSeq5_ES	4/4	6	140			:
Seq	Elect	5963	MA_TrancePhras1	4/4	1	130			:
Seq	Elect	5964	MA_TrancePhras2	4/4	1	130			:
Seq	Elect	5965	MA_TrancePhras3	4/4	1	130			:
Seq	Elect	5966	MA_TrancePhras4	4/4	1	130			:
Seq	Elect	5967	MA_TrancePhras5	4/4	1	130			:
Seq	Elect	5968	MA_TrancePhras6	4/4	1	130			:
Seq	Elect	5969	MA_TrancePhras7	4/4	1	130			:
Seq	Elect	5970	MA_TrancePhras8	4/4	2	145			:

Main Category	Sub Category	ARP No.	ARP Name	Time Signature	Length	Original Tempo	Accent	Random SFX	Voice Type
Seq	Elect	5971	MA_TrancePhras9	4/4	1	145			Syn Comp/Lead
Seq	Elect	5972	MA_TrancePhrs10	4/4	2	145			:
Seq	Elect	5973	MA_TrancePhrs11	4/4	2	145			:
Seq	Elect	5974	MA_TrancePhrs12	4/4	2	145			:
Seq	Elect	5975	MA_TrancePhrs13	4/4	2	145			:
Seq	Elect	5976	MA_TrancePhrs14	4/4	1	145			:
Seq	Elect	5977	MA_TrancePhrs15	4/4	1	145			:
Seq	Elect	5978	MA_PsychePhras1_ES	4/4	1	143			:
Seq	Elect	5979	MA_PsychePhras2_ES	4/4	1	143			:
Seq	Elect	5980	MA_PsychePhras3_ES	4/4	2	143			:
Seq	Elect	5981	MA_PsychePhras4_ES	4/4	2	143			:
Seq	Elect	5982	MA_PsychePhras5_ES	4/4	2	143			:
Seq	Elect	5983	MA_HyperTrance1_ES	4/4	1	143			:
Seq	Elect	5984	MA_HyperTrance2_ES	4/4	2	143			:
Seq	Elect	5985	MA_HyperTrance3_ES	4/4	1	143			:
Seq	Elect	5986	MA_HyperTrance4_ES	4/4	1	143			:
Seq	Elect	5987	MA_HyperTrance5_ES	4/4	1	143			:
Seq	Elect	5988	MA_T-Line Seq_ES	4/4	1	140			:
Seq	Elect	5989	MC1_Dream Dance	4/4	1	136			:
Seq	Elect	5990	FC1_Dream Dance	4/4	1	136			:
Seq	Elect	5991	MA2_Dream Dance	4/4	1	136			:
Seq	Elect	5992	MD2_Dream Dance	4/4	1	136			:
Seq	Elect	5993	FC2_Dream Dance	4/4	1	136			:
Seq	Elect	5994	MB3_Dream Dance	4/4	1	136			:
Seq	Elect	5995	MD1_Ibiza	4/4	2	135			:
Seq	Elect	5996	IA1_Ibiza	4/4	8	135			:
Seq	Elect	5997	MB2_Ibiza_ES	4/4	2	135			:
Seq	Elect	5998	MD2_Ibiza_ES	4/4	2	135			:
Seq	Elect	5999	MB3_Ibiza_ES	4/4	2	135			:
Seq	Elect	6000	MC3_Ibiza_ES	4/4	2	135			:
Seq	Elect	6001	MA_Retro Pop	4/4	1	126			:
Seq	Elect	6002	MD_Retro Pop	4/4	2	126			:
Seq	Elect	6003	FC_Retro Pop	4/4	1	100			:
Seq	Elect	6004	MA_TeknoPhrs1 /1_XS	4/4	2	130			:
Seq	Elect	6005	MA_TeknoPhrs1 /2_XS	4/4	1	130			:
Seq	Elect	6006	MA_TeknoPhrs1 /3_XS	4/4	1	130			:
Seq	Elect	6007	MA_TeknoPhrs1 /4_XS	4/4	1	130			:
Seq	Elect	6008	MA_TeknoPhrs1 /5_XS	4/4	1	110			:
Seq	Elect	6009	MA_TeknoPhrs1 /6_XS	4/4	1	100			:
Seq	Elect	6010	MA_TeknoPhras2 /1	4/4	2	120			:
Seq	Elect	6011	MA_TeknoPhras2 /2	4/4	2	120			:
Seq	Elect	6012	MA_TeknoPhras2 /3	4/4	2	120			:
Seq	Elect	6013	MA_TeknoAttack1_ES	4/4	2	143			:
Seq	Elect	6014	MA_TeknoAttack2_ES	4/4	1	143			:
Seq	Elect	6015	MA_TeknoAttack3_ES	4/4	1	143			:
Seq	Elect	6016	MA_TeknoAttack4_ES	4/4	1	143			:
Seq	Elect	6017	MA_TeknoAttack5_ES	4/4	1	143			:
Seq	Elect	6018	MA_Acid A1	4/4	2	127			:
Seq	Elect	6019	MA_Acid A2	4/4	2	127			:
Seq	Elect	6020	MA_Acid A3	4/4	2	127			:
Seq	Elect	6021	MA_Acid A4	4/4	2	127			:
Seq	Elect	6022	MA_Acid A5	4/4	2	127			:
Seq	Elect	6023	MA_Acid A6	4/4	2	127			:
Seq	Elect	6024	MA_Acid B1	4/4	2	127			:
Seq	Elect	6025	MA_Acid B2	4/4	2	127			:
Seq	Elect	6026	MA_Acid B3	4/4	2	127			:
Seq	Elect	6027	MA_Acid B4	4/4	2	127			:
Seq	Elect	6028	MA_Acid B5	4/4	2	127			:
Seq	Elect	6029	MA_Acid B6	4/4	2	127			:
Seq	Elect	6030	MA_Acid C1	4/4	2	127			:
Seq	Elect	6031	MA_Acid C2	4/4	2	127			:
Seq	Elect	6032	MA_Acid C3	4/4	2	127			:
Seq	Elect	6033	MA_Acid C4	4/4	2	127			:
Seq	Elect	6034	MA_Acid C5	4/4	2	127			:
Seq	Elect	6035	MA_Acid C6	4/4	2	127			:
Seq	Elect	6036	MA_SynArp1	4/4	1	130			:
Seq	Elect	6037	MA_SynArp2	4/4	2	130			:
Seq	Elect	6038	MA_SynArp3	4/4	1	130			:
Seq	Elect	6039	MA_SynArp4	4/4	1	130			:
Seq	Elect	6040	MA_SynArp5	4/4	1	130			:
Seq	Elect	6041	MA_SynArp6	4/4	1	124			:
Seq	Elect	6042	MA_SynArp7	4/4	1	120			:
Seq	Elect	6043	MA_SynArp8	4/4	1	130			:
Seq	Elect	6044	MA_SynArp9	4/4	1	130			:
Seq	Elect	6045	MA_SynArp10	4/4	1	130			:
Seq	Elect	6046	MA_SynArp11	4/4	2	130			:
Seq	Elect	6047	MA_SynArp12	4/4	1	90			:
Seq	Elect	6048	MA_SynArp13	4/4	2	124			:
Seq	Elect	6049	MA_SynArp14	4/4	1	130			:
Seq	Elect	6050	MA_SynArp15	4/4	1	130			:
Seq	Elect	6051	MA_SynArp16	4/4	1	130			:
Seq	Elect	6052	MA_SynArp17	4/4	1	90			:
Seq	Elect	6053	MA_SynArp18	4/4	1	130			:

Main Category	Sub Category	ARP No.	ARP Name	Time Signature	Length	Original Tempo	Accent	Random SFX	Voice Type
Seq	Elect	6054	MA_SynArp19	4/4	1	120			Syn Comp/Lead
Seq	Elect	6055	MA_SynArp20	4/4	1	120			:
Seq	Elect	6056	MA_SynArp21	4/4	1	124			:
Seq	Elect	6057	MA_SynArp22	4/4	1	120			:
Seq	Elect	6058	MA_SynArp23	4/4	1	138			:
Seq	Elect	6059	MA_SynArp24	4/4	1	138			:
Seq	Elect	6060	MA_SynArp25	4/4	1	120			:
Seq	Elect	6061	MA_SynArp26	4/4	1	120			:
Seq	Elect	6062	MA_SynArp27	4/4	1	120			:
Seq	Elect	6063	MA_SynArp28	1/4	10	125			:
Seq	Elect	6064	MA_SynArp29	4/4	5	120			:
Seq	Elect	6065	MA_Melody1	4/4	1	70			:
Seq	Elect	6066	MA_Melody2	4/4	1	120			:
Seq	Elect	6067	MA_Melody3	4/4	1	70			:
Seq	Elect	6068	MA_Melody4	4/4	1	70			:
Seq	Elect	6069	MA_Melody5	4/4	1	70			:
Seq	Elect	6070	MA_Melody6	4/4	1	70			:
Seq	Elect	6071	MA_Melody7	4/4	1	70			:
Seq	Elect	6072	MA_Melody8	4/4	1	70			:
Seq	Elect	6073	MA_Melody9	4/4	1	70			:
Seq	Elect	6074	MA_Melody10	4/4	1	70			:
Seq	Elect	6075	MA_Melody11	4/4	1	70			:
Seq	Elect	6076	MA_Melody12	4/4	1	70			:
Seq	Elect	6077	MA_Melody13	4/4	1	70			:
Seq	Elect	6078	MA_Melody14	4/4	1	70			:
Seq	Elect	6079	MA_Melody15	4/4	1	70			:
Seq	Elect	6080	MA_Melody16	4/4	1	70			:
Seq	Elect	6081	MA_Melody17	4/4	1	70			:
Seq	Elect	6082	MA_Melody18	4/4	1	70			:
Seq	Elect	6083	MA_Melody19	4/4	1	70			:
Seq	Elect	6084	MA_Melody20	4/4	1	70			:
Seq	Elect	6085	MA_Melody21	4/4	1	70			:
Seq	Elect	6086	MA_Melody22	4/4	1	70			:
Seq	Elect	6087	MA_Melody23	4/4	1	70			:
Seq	Elect	6088	MA_Melody24	4/4	1	70			:
Seq	Elect	6089	MA_Melody25	4/4	1	70			:
Seq	Elect	6090	MA_Melody26	4/4	1	70			:
Seq	Elect	6091	MA_Melody27	4/4	1	70			:
Seq	Elect	6092	MA_SynthPhrase1_XS	4/4	1	70			:
Seq	Elect	6093	MA_SynthPhrase2_XS	4/4	1	70			:
Seq	Elect	6094	MA_SynthPhrase3_XS	4/4	1	70			:
Seq	Elect	6095	MA_SynthPhrase4_XS	4/4	1	70			:
Seq	Elect	6096	MA_SynthPhrase5_XS	4/4	1	70			:
Seq	Elect	6097	MA_SynthPhrase6_XS	4/4	1	70			:
Seq	Elect	6098	MA_SynthPhrase7_XS	4/4	1	70			:
Seq	Elect	6099	MA_SynthPhrase8_XS	4/4	1	70			:
Seq	Elect	6100	MA_SynthPhrase9_XS	4/4	1	70			:
Seq	Elect	6101	MA_SynthPhras10_XS	4/4	1	70			:
Seq	Elect	6102	MA_SynthPhras11_XS	4/4	1	70			:
Seq	Elect	6103	MA_SynthPhras12_XS	4/4	1	70			:
Seq	Elect	6104	MA_SynthPhras13_XS	4/4	1	130			:
Seq	Elect	6105	MA_SynthPhras14_XS	4/4	1	130			:
Seq	Elect	6106	MA_SynthPhras15_XS	4/4	1	130			:
Seq	Elect	6107	MA_SynthPhras16_XS	4/4	1	130			:
Seq	Elect	6108	MA_SynthPhras17_XS	4/4	1	130			:
Seq	Elect	6109	MA_SynthPhras18_XS	4/4	1	130			:
Seq	Elect	6110	MA_SynthPhras19_XS	4/4	1	130			:
Seq	Elect	6111	MA_SynthPhras20_XS	4/4	1	130			:
Seq	Elect	6112	MA_SynthPhras21_XS	4/4	1	130			:
Seq	Elect	6113	MA_SynthPhras22_XS	4/4	1	130			:
Seq	Elect	6114	MA_SynthPhras23_XS	4/4	1	130			:
Seq	Elect	6115	MA_SynthPhras24_XS	4/4	1	130			:
Seq	Elect	6116	MA_SynthPhras25_XS	4/4	1	130			:
Seq	Elect	6117	MA_SynthPhras26_XS	4/4	1	130			:
Seq	Elect	6118	MA_SynthPhras27_XS	4/4	1	130			:
Seq	Elect	6119	MA_SynthPhras28_XS	4/4	1	130			:
Seq	Elect	6120	MA_SynthPhras29_XS	4/4	1	130			:
Seq	Elect	6121	MA_SynthPhras30_XS	4/4	1	130			:
Seq	Elect	6122	MA_SynthPhras31_XS	4/4	1	130			:
Seq	Elect	6123	MA_SynthPhras32_XS	4/4	1	130			:
Seq	Elect	6124	MA_SynthPhras33_XS	4/4	1	130			:
Seq	Elect	6125	MA_SynthPhras34_XS	4/4	1	140			:
Seq	Elect	6126	MA_SynthPhras35_XS	4/4	1	130			:
Seq	Elect	6127	MA_SynthPhras36_XS	4/4	1	130			:
Seq	Elect	6128	MA_SynthPhras37_XS	4/4	1	130			:
Seq	Elect	6129	MA_SynthPhras38_XS	4/4	1	130			:
Seq	Elect	6130	MA_SynthPhras39_XS	4/4	1	130			:
Seq	Elect	6131	MA_SynthPhras40_XS	4/4	1	120			:
Seq	Elect	6132	MA_SynthPhras41_XS	4/4	1	120			:
Seq	Elect	6133	MA_SynthPhras42_XS	4/4	1	140			:
Seq	Elect	6134	MA_SynthPhras43_XS	4/4	4	140			:
Seq	Elect	6135	MA_SynthPhras44_XS	4/4	1	136			:
Seq	Elect	6136	MA_SynthPhras45_XS	4/4	1	136			:

Main Category	Sub Category	ARP No.	ARP Name	Time Signature	Length	Original Tempo	Accent	Random SFX	Voice Type
Seq	Elect	6137	MA_SynthPhras46_XS	4/4	2	135			Syn Comp/Lead
Seq	Elect	6138	MA_SynthPhras47_XS	4/4	1	130			:
Seq	Elect	6139	MA_SynthPhras48_XS	4/4	1	130			:
Seq	Elect	6140	MA_SynthPhras49_XS	4/4	1	130			:
Seq	Elect	6141	MA_SynthPhras50_XS	4/4	1	116			:
Seq	Elect	6142	MA_SynthPhras51_XS	4/4	1	100			:
Seq	Elect	6143	MA_SynthPhras52_XS	4/4	1	138			:
Seq	Elect	6144	MA_Electro1	4/4	1	130			:
Seq	Elect	6145	MA_Electro2	4/4	1	130			:
Seq	Elect	6146	MA_Electro3	4/4	1	130			:
Seq	Elect	6147	MA_Electro4	4/4	1	130			:
Seq	Elect	6148	MA_Electro5	4/4	1	130			:
Seq	Elect	6149	MA_Electro6	4/4	1	130			:
Seq	Elect	6150	MA_Electro7	4/4	1	130			:
Seq	Elect	6151	MA_Electro8	4/4	1	130			:
Seq	Elect	6152	MA_Electro9	4/4	1	130			:
Seq	Elect	6153	MA_Electro10	4/4	1	130			:
Seq	Elect	6154	MA_Electro11	4/4	1	130			:
Seq	Elect	6155	MA_Electro12	4/4	1	130			:
Seq	Elect	6156	MA_Electro13	4/4	1	130			:
Seq	Elect	6157	MA_Electro14	4/4	1	130			:
Seq	Elect	6158	MA_CompUBass1	4/4	1	130			:
Seq	Elect	6159	MA_CompUBass2	4/4	1	130			:
Seq	Elect	6160	MA_CompUBass3	4/4	1	130			:
Seq	Elect	6161	MA_CompUBass4	4/4	1	130			:
Seq	Elect	6162	MA_Digi Seq1_ES	4/4	2	106			:
Seq	Elect	6163	MA_Digi Seq2_ES	4/4	2	106			:
Seq	Elect	6164	MA_Digi Seq3_ES	4/4	2	106			:
Seq	Elect	6165	MA_Digi Seq4_ES	4/4	1	106			:
Seq	Elect	6166	MA_Digi Seq5_ES	4/4	1	106			:
Seq	Elect	6167	MA_DigySeq1_ES	4/4	4	135			:
Seq	Elect	6168	MA_DigySeq2_ES	4/4	2	135			:
Seq	Elect	6169	MA_DigySeq3_ES	4/4	2	135			:
Seq	Elect	6170	MA_DigySeq4_ES	4/4	2	135			:
Seq	Elect	6171	MA_DigySeq5_ES	4/4	1	135			:
Seq	Elect	6172	MA_Seq S&H1	4/4	4	120			:
Seq	Elect	6173	MA_Seq S&H2	4/4	4	120			:
Seq	Elect	6174	MA_Poly Arp1	4/4	1	120			:
Seq	Elect	6175	MA_Poly Arp2	4/4	1	120			:
Seq	Elect	6176	MA_Boiler1	4/4	1	120			:
Seq	Elect	6177	MA_Boiler2	4/4	1	120			:
Seq	Elect	6178	MA_Boiler3	4/4	1	120			:
Seq	Elect	6179	MA_Boiler4	4/4	1	110			:
Seq	Elect	6180	MA_Bees1	4/4	1	118			:
Seq	Elect	6181	MA_Bees2	4/4	1	118			:
Seq	Elect	6182	MA_Bees3	4/4	1	118			:
Seq	Elect	6183	MA_Syncop1	4/4	2	120			:
Seq	Elect	6184	MA_Tek Echo1	4/4	2	120			:
Seq	Elect	6185	MA_Super Arp	4/4	2	120			:
Seq	Elect	6186	MA_Space Arp	4/4	2	120			:
Seq	Elect	6187	MA_Step Line	4/4	1	120			:
Seq	Elect	6188	MA_Acid Line	4/4	1	120			:
Seq	Elect	6189	MA_Ana Seq	4/4	1	120			:
Seq	Elect	6190	MA_Ascorbic	4/4	1	150			:
Seq	Elect	6191	MA_Beeperz	4/4	2	104			:
Seq	Elect	6192	MA_Doves	4/4	1	150			:
Seq	Elect	6193	MA_Europluk	4/4	1	105			:
Seq	Elect	6194	MA_Hardcore	4/4	3	150			:
Seq	Elect	6195	MA_Harmo	4/4	1	150			:
Seq	Elect	6196	MA_Lamb	4/4	1	125			:
Seq	Elect	6197	MA_Ocean	4/4	1	120			:
Seq	Elect	6198	MA_Orbit	4/4	1	140			:
Seq	Elect	6199	MA_Pitzy	4/4	1	105			:
Seq	Elect	6200	MA_Planet	4/4	1	120			:
Seq	Elect	6201	MA_Poly Dance	4/4	1	120			:
Seq	Elect	6202	MA_Popcom	4/4	1	120			:
Seq	Elect	6203	MA_Puls Line	4/4	2	120			:
Seq	Elect	6204	MA_Simple	4/4	2	150			:
Seq	Elect	6205	MA_Split Arp	4/4	1	120			:
Seq	Elect	6206	MA_Step Seq	4/4	1	120			:
Seq	Elect	6207	MA_SyncopEcho	4/4	2	120			:
Seq	Elect	6208	MA_Tek Bubble	4/4	1	128			:
Seq	Elect	6209	MA_Thips	4/4	1	100			:
Seq	Elect	6210	MA_Waggle	4/4	1	140			:
Seq	World	6211	MA_Latin House	4/4	4	138			:
Seq	World	6212	MB_Latin House	4/4	2	138			:
Seq	Genrl	6213	MA_Up Oct1	4/4	1	120			:
Seq	Genrl	6214	MA_Up Oct2	4/4	1	120			:
Seq	Genrl	6215	MA_Up Oct3	4/4	1	120			:
Seq	Genrl	6216	MA_Up Oct4	4/4	1	120			:
Seq	Genrl	6217	MA_Down Oct1	4/4	1	120			:
Seq	Genrl	6218	MA_Down Oct2	4/4	1	120			:
Seq	Genrl	6219	MA_Down Oct3	4/4	1	120			:

Main Category	Sub Category	ARP No.	ARP Name	Time Signature	Length	Original Tempo	Accent	Random SFX	Voice Type
Seq	Genrl	6220	MA_Down Oct4	4/4	1	120			Syn Comp/Lead
Seq	Genrl	6221	MA_U/D A Oct1	4/4	1	120			:
Seq	Genrl	6222	MA_U/D A Oct2	4/4	1	120			:
Seq	Genrl	6223	MA_U/D A Oct3	4/4	1	120			:
Seq	Genrl	6224	MA_U/D A Oct4	4/4	1	120			:
Seq	Genrl	6225	MA_U/D B Oct1	4/4	1	120			:
Seq	Genrl	6226	MA_U/D B Oct2	4/4	1	120			:
Seq	Genrl	6227	MA_U/D B Oct3	4/4	1	120			:
Seq	Genrl	6228	MA_U/D B Oct4	4/4	1	120			:
Seq	Genrl	6229	MA_Random Oct1	4/4	1	120			:
Seq	Genrl	6230	MA_Random Oct2	4/4	1	120			:
Seq	Genrl	6231	MA_Random Oct3	4/4	1	120			:
Seq	Genrl	6232	MA_Random Oct4	4/4	1	120			:
Seq	Genrl	6233	MA_Oct2 Up	4/4	1	120			:
Seq	Genrl	6234	MA_Oct4 Up	4/4	1	120			:
Seq	Genrl	6235	MA_Unison Up	4/4	1	120			:
Seq	Genrl	6236	MA_Up&Alt1	4/4	1	120			:
Seq	Genrl	6237	MA_Up&Down1	4/4	1	120			:
Seq	Genrl	6238	MA_Up&Down2	4/4	1	120			:
Seq	Genrl	6239	MA_Up&Down3	4/4	1	120			:
Seq	Genrl	6240	MA_Up&Down4	4/4	1	120			:
Seq	Genrl	6241	MA_Up&Random1	4/4	1	120			:
Seq	Genrl	6242	MA_Up&Random2	4/4	1	120			:
Seq	Genrl	6243	MA_Up&Random3	4/4	1	120			:
Seq	Genrl	6244	MA_Up&Random4	4/4	1	120			:
Seq	Genrl	6245	MA_Oct Seq1	4/4	1	130			:
Seq	Genrl	6246	MA_Oct Seq2	4/4	1	130			:
Seq	Genrl	6247	MA_Oct Seq3	4/4	1	130			:
Seq	Genrl	6248	MA_Oct Seq4	4/4	1	130			:
Seq	Genrl	6249	MA_Oct Seq5	4/4	1	130			:
Seq	Genrl	6250	MA_Oct Seq6	4/4	1	90			:
Seq	Genrl	6251	MA_Oct Seq7	4/4	1	90			:
Seq	Genrl	6252	MA_Oct Seq8	4/4	1	90			:
Seq	Genrl	6253	MA_Random Seq1	4/4	1	90			:
Seq	Genrl	6254	MA_Random Seq2	4/4	1	90			:
Seq	Genrl	6255	MA_Random Seq3	4/4	1	90			:
Seq	Genrl	6256	MA_RndmNotesSeq	4/4	1	70			:
Seq	Genrl	6257	MA_Vel Grv1	4/4	1	134			:
Seq	Genrl	6258	MA_Vel Grv2	4/4	1	134			:
Seq	Genrl	6259	MA_X-Sweep1	4/4	1	140			:
Seq	Genrl	6260	MA_X-Sweep2	4/4	1	140			:
Seq	Genrl	6261	MA_X-Sweep3	4/4	1	140			:
Seq	Genrl	6262	MA_Simple1	4/4	1	130			:
Seq	Genrl	6263	MA_Simple2	4/4	1	130			:
Seq	Genrl	6264	MA_Simple3	4/4	1	130			:
Seq	Genrl	6265	MA_Simple4	4/4	1	130			:
Seq	Genrl	6266	MA_Simple5	4/4	1	130			:
Seq	Genrl	6267	MA_Basic1	4/4	1	130			:
Seq	Genrl	6268	MA_Basic2	4/4	1	130			:
Seq	Genrl	6269	MA_Basic3	4/4	1	130			:
Seq	Genrl	6270	MA_FilthSQ1	4/4	1	130			:
Seq	Genrl	6271	MA_FilthSQ2	4/4	1	130			:
Seq	Genrl	6272	MA_FilthSQ3	4/4	1	130			:
Seq	Genrl	6273	MA_FilthSQ4	4/4	1	130			:
Seq	Genrl	6274	MA_FilthSQ5	4/4	1	130			:
Seq	Genrl	6275	MA_FilthSQ6	4/4	1	130			:
Seq	Genrl	6276	MA_MuteArp1	4/4	1	120			:
Seq	Genrl	6277	MA_MuteArp2	4/4	1	120			:
Seq	Genrl	6278	MA_Mute Line	4/4	1	134			:
Seq	Genrl	6279	MA_Chodal	4/4	2	150			:
Seq	Genrl	6280	MA_Wavetable8th	4/4	1	120			:
Seq	Genrl	6281	MA_Wavetable16th	4/4	1	90			:
Chord	R&B	6282	MA_Funky Chop	4/4	1	120			:
Chord	Elect	6283	MA_Chill Out	4/4	2	79			:
Chord	Elect	6284	MB_Chill Out	4/4	2	79			:
Chord	Elect	6285	FA_Chill Out	4/4	1	79			:
Chord	Elect	6286	MA_ChillnChord1	4/4	1	90			:
Chord	Elect	6287	MA_ChillnChord2	4/4	1	90			:
Chord	Elect	6288	MA_ChillnChord3	4/4	1	90			:
Chord	Elect	6289	MA_ChillnChord4	4/4	1	90			:
Chord	Elect	6290	MA_ChillnChord5	4/4	1	90			:
Chord	Elect	6291	MA_ChillnChord6	4/4	1	90			:
Chord	Elect	6292	MA_TranceRtm1	4/4	4	135			:
Chord	Elect	6293	MA_TranceRtm2	4/4	4	140			:
Chord	Elect	6294	MA_TranceRtm3	4/4	4	140			:
Chord	Elect	6295	MA_TranceSlab	4/4	2	140			:
Chord	Elect	6296	MA_T-Line Chd	4/4	4	140			:
Chord	Elect	6297	IA_Dream Dance	4/4	2	136			:
Chord	Elect	6298	MA_ibiza	4/4	1	135			:
Chord	Elect	6299	MB_ibiza	4/4	2	135			:
Chord	Elect	6300	MC_ibiza	4/4	2	135			:
Chord	Elect	6301	MD_ibiza	4/4	2	135			:
Chord	Elect	6302	IA_ibiza	4/4	8	135			:

Arpeggio Type List

Main Category	Sub Category	ARP No.	ARP Name	Time Signature	Length	Original Tempo	Accent	Random SFX	Voice Type
Chord	Elect	6303	FA_Ibiza	4/4	1	135			Syn Comp/Lead
Chord	Elect	6304	FB_Ibiza	4/4	1	135			:
Chord	Elect	6305	MB_Garage 2	4/4	2	127			:
Chord	Elect	6306	MC_Garage 2	4/4	2	127			:
Chord	Elect	6307	MD_Garage 2	4/4	2	127			:
Chord	Elect	6308	IA_Garage 2	4/4	2	127			:
Chord	Elect	6309	FA_Garage 2	4/4	2	127			:
Chord	Elect	6310	MA_Syncopa2	4/4	2	120			:
Chord	Elect	6311	MA_Tek Echo2	4/4	2	120			:
Chord	Elect	6312	MA_Fugue	4/4	2	120			:
Chord	Elect	6313	MA_Rave Swp	4/4	4	135			:
Chord	Elect	6314	MA_Rosync	4/4	1	120			:
Chord	Elect	6315	MA_Synclav	4/4	2	140			:
Chord	Elect	6316	MA_HiFive	4/4	1	118			:
Chord	Genrl	6317	MA_Syn Chord1	4/4	1	130			:
Chord	Genrl	6318	MA_Syn Chord2	4/4	1	90			:
Chord	Genrl	6319	MA_Syn Chord3	4/4	1	120			:
Chord	Genrl	6320	MA_Syn Chord4	4/4	1	130			:
Chord	Genrl	6321	MA_Syn Chord5	4/4	1	130			:
Chord	Genrl	6322	MA_Syn Chord6	4/4	1	130			:
Chord	Genrl	6323	MA_Syn Chord7	4/4	1	130			:
Chord	Genrl	6324	MA_Syn Chord8	4/4	1	90			:
Chord	Genrl	6325	MA_Syn Chord9	4/4	1	120			:
Chord	Genrl	6326	MA_Syn Chord10	4/4	1	116			:
Chord	Genrl	6327	MA_Syn Chord11	4/4	4	130			:
Chord	Genrl	6328	MA_Syn Chord12	4/4	1	124			:
Chord	Genrl	6329	MA_Syn Chord13	4/4	1	140			:
Chord	Genrl	6330	MA_Syn Chord14	4/4	2	130			:
Chord	Genrl	6331	MA_Syn Chord15	4/4	2	134			:
Chord	Genrl	6332	MA_Syn Chord16	4/4	1	138			:
Chord	Genrl	6333	MA_BassChord1	4/4	2	130			:
Chord	Genrl	6334	MA_BassChord2	4/4	2	130			:
Chord	Genrl	6335	MA_BassChord3	4/4	2	130			:
Chord	Genrl	6336	MA_BassChord4	4/4	2	130			:
Chord	Genrl	6337	MA_BassChord5	4/4	2	130			:
Chord	Genrl	6338	MA_BassChord6	4/4	2	130			:
Chord	Genrl	6339	MA_BassChord7	4/4	2	130			:
Chord	Genrl	6340	MA_BassChord8	4/4	2	130			:
Chord	Genrl	6341	MA_BassChord9	4/4	1	130			:
Chord	Genrl	6342	MA_BassChord10	4/4	1	130			:
Chord	Genrl	6343	MA_BassChord11	4/4	1	130			:
Chord	Genrl	6344	MA_BassChord12	4/4	1	130			:
Chord	Genrl	6345	MA_BassChord13	4/4	2	130			:
Chord	Genrl	6346	MA_BassChord14	4/4	1	130			:
Chord	Genrl	6347	MA_BassChord15	4/4	2	130			:
Chord	Genrl	6348	MA_BassChord16	4/4	1	130			:
Chord	Genrl	6349	MA_BassChord17	4/4	1	130			:
Chord	Genrl	6350	MA_BassChord18	4/4	2	130			:
Chord	Genrl	6351	MA_BassChord19	4/4	1	130			:
Chord	Genrl	6352	MA_BassChord20	4/4	1	130			:
Chord	Genrl	6353	MA_Chord A1B1	4/4	1	120			:
Chord	Genrl	6354	MA_Chord A1B2	4/4	1	120			:
Chord	Genrl	6355	MA_Chord A1B4	4/4	1	120			:
Chord	Genrl	6356	MA_ChordRandom1	4/4	1	120			:
Chord	Genrl	6357	MA_ChordRandom2	4/4	1	120			:
Chord	Genrl	6358	MA_ChordRandom4	4/4	1	120			:
Hybrd	Comb	6359	MA_Hybrid1	4/4	1	130			Syn Comp/Lead/Pad
Hybrd	Comb	6360	MA_Hybrid2	4/4	1	130			:
Hybrd	Comb	6361	MA_Hybrid3	4/4	1	130			:
Hybrd	Comb	6362	MA_Hybrid4	4/4	1	130			:
Hybrd	Comb	6363	MA_Hybrid5	4/4	1	95			:
Hybrd	Comb	6364	MA_Hybrid6	4/4	1	130			:
Hybrd	Comb	6365	MA_Hybrid7	4/4	1	130			:
Hybrd	Comb	6366	MA_Hybrid8	4/4	1	90			:
Hybrd	Comb	6367	MA_Hybrid9	4/4	1	130			:
Hybrd	Comb	6368	MA_Hybrid10	4/4	1	130			:
Hybrd	Comb	6369	MA_Hybrid11	4/4	1	130			:
Hybrd	Comb	6370	MA_Hybrid12	4/4	1	90			:
Hybrd	Comb	6371	MA_Hybrid13	4/4	1	130			:
Hybrd	Comb	6372	MA_Hybrid14	4/4	1	130			:
Hybrd	Comb	6373	MA_Hybrid15	4/4	1	130			:
Hybrd	Comb	6374	MA_Hybrid16	4/4	1	106			:
Hybrd	Comb	6375	MA_Hybrid17	4/4	1	130			:
Hybrd	Comb	6376	MA_Hybrid18	4/4	1	110			:
Hybrd	Comb	6377	MA_Hybrid19	4/4	1	100			:
Hybrd	Comb	6378	MA_Hybrid20	4/4	1	116			:
Hybrd	Comb	6379	MA_Hybrid1CF1	4/4	1	130			:
Hybrd	Comb	6380	MA_Hybrid1CF2	4/4	1	130			:
Hybrd	Comb	6381	MA_Hybrid1CF3	4/4	1	130			:
Hybrd	Comb	6382	MA_Hybrid1CF4	4/4	1	130			:
Hybrd	Comb	6383	MA_Hybrid3 CF	4/4	1	120			:
Hybrd	Comb	6384	MA_Hybrid21CF	4/4	1	100			:
Hybrd	Comb	6385	MA_Hybrid22CF	4/4	1	138			:

Main Category	Sub Category	ARP No.	ARP Name	Time Signature	Length	Original Tempo	Accent	Random SFX	Voice Type
Hybrd	Comb	6386	MA_Hybrid23CF	4/4	1	130			Syn Comp/Lead/Pad
Hybrd	Comb	6387	MA_Hybrid24CF	4/4	1	130			:
Hybrd	Comb	6388	MA_Hybrid25CF	4/4	1	96			:
Hybrd	Comb	6389	MA_Parade	4/4	2	120			:
Hybrd	Comb	6390	MA_SynPop Comb1	4/4	4	90			:
Hybrd	Comb	6391	MA_SynPop Comb2	4/4	4	90			:
Hybrd	Comb	6392	MA_Trancy1_ES	4/4	1	140			:
Hybrd	Comb	6393	MA_Trancy2	4/4	4	140			:
Hybrd	Comb	6394	MA_Trancy3	4/4	16	140			:
Hybrd	Zone	6395	MA_2Z_Comb SQ1	4/4	2	90			:
Hybrd	Zone	6396	MA_2Z_Comb SQ2	4/4	1	70			:
Hybrd	Zone	6397	MA_2Z_Comb SQ3	4/4	1	90			:
Hybrd	Zone	6398	MA_2Z_Comb SQ4	4/4	1	130			:
Hybrd	Zone	6399	MA_2Z_Comb SQ5	4/4	2	130			:
Hybrd	Zone	6400	MA_2Z_Comb SQ6	4/4	2	130			:
Hybrd	Zone	6401	MA_2Z_Comb SQ7	4/4	1	130			:
Hybrd	Zone	6402	MA_2Z_Comb SQ8	4/4	1	70			:
Hybrd	Zone	6403	MA_2Z_Comb SQ9	4/4	2	130			:
Hybrd	Zone	6404	MA_2Z_Comb SQ10	4/4	2	70			:
Hybrd	Zone	6405	MA_2Z_Comb SQ11	4/4	1	70			:
Hybrd	Zone	6406	MA_2Z_Comb SQ12	4/4	1	70			:
Hybrd	Zone	6407	MA_2Z_Comb SQ13	4/4	2	90			:
Hybrd	Zone	6408	MA_4Z_HybVel1	4/4	1	96			:
Hybrd	Zone	6409	MA_4Z_HybVel2	4/4	1	96			:
Hybrd	Zone	6410	MA_4Z_HybVel3	4/4	1	96			:
Hybrd	Zone	6411	MA_4Z_HybVel4	4/4	1	96			:
Hybrd	Zone	6412	MA_4Z_HybVel5	4/4	1	96			:
Hybrd	Zone	6413	MA_4Z_HybVel6	4/4	1	96			:
Hybrd	Zone	6414	MA_4Z_HybVel7	4/4	1	96			:
Hybrd	Zone	6415	MA_4Z_HybVel8	4/4	1	96			:
Hybrd	Zone	6416	MA_4Z_HybVel9	4/4	2	120			:
Hybrd	Zone	6417	MA_4Z_HybVel10	4/4	2	120			:
Hybrd	Zone	6418	MA_4Z_HybVel11	4/4	2	120			:
Hybrd	Zone	6419	MA_4Z_HybVel12	4/4	2	120			:
Hybrd	Zone	6420	MA_4Z_HybVel13	4/4	2	120			:
Hybrd	Zone	6421	MA_4Z_HybVel14	4/4	2	120			:
Hybrd	Zone	6422	MA_4Z_HybVel15	4/4	2	120			:
Hybrd	Zone	6423	MA_4Z_HybVel16	4/4	2	120			:
Hybrd	Zone	6424	MA_4Z_4Zone1A	4/4	2	130			:
Hybrd	Zone	6425	MA_4Z_4Zone1B	4/4	2	130			:
Hybrd	Zone	6426	MA_4Z_4Zone1C	4/4	2	130			:
Hybrd	Zone	6427	MA_4Z_4Zone1D	4/4	2	130			:
Hybrd	Zone	6428	MA_4Z_4Zone1E	4/4	2	130			:
Hybrd	Zone	6429	MA_4Z_4Zone2A	4/4	1	130			:
Hybrd	Zone	6430	MA_4Z_4Zone2B	4/4	1	130			:
Hybrd	Zone	6431	MA_4Z_4Zone2C	4/4	1	130			:
Hybrd	Zone	6432	MA_4Z_4Zone2D	4/4	1	130			:
Hybrd	Zone	6433	MA_4Z_4Zone2E	4/4	1	130			:
Hybrd	Zone	6434	MA_4Z_4Zone3A	4/4	1	70			:
Hybrd	Zone	6435	MA_4Z_4Zone3B	4/4	1	94			:
Hybrd	Zone	6436	MA_4Z_4Zone3C	4/4	1	94			:
Hybrd	Zone	6437	MA_4Z_4Zone3D	4/4	1	94			:
Hybrd	Zone	6438	MA_4Z_4Zone3E	4/4	1	94			:
Hybrd	Zone	6439	MA_4Z_4Zone4A	4/4	1	70			:
Hybrd	Zone	6440	MA_4Z_4Zone4B	4/4	1	70			:
Hybrd	Zone	6441	MA_4Z_4Zone4C	4/4	1	70			:
Hybrd	Zone	6442	MA_4Z_4Zone4D	4/4	1	70			:
Hybrd	Zone	6443	MA_4Z_4Zone4E	4/4	1	70			:
Hybrd	Zone	6444	MA_4Z_4Zone5A	4/4	1	70			:
Hybrd	Zone	6445	MA_4Z_4Zone5B	4/4	1	70			:
Hybrd	Zone	6446	MA_4Z_4Zone5C	4/4	1	70			:
Hybrd	Zone	6447	MA_4Z_4Zone5D	4/4	1	70			:
Hybrd	Zone	6448	MA_4Z_4Zone5E	4/4	1	70			:
Hybrd	Zone	6449	MA_4Z_HybPrc1	4/4	1	130			:
Hybrd	Zone	6450	MA_4Z_HybPrc2	4/4	1	130			:
Hybrd	Zone	6451	MA_4Z_HybPrc3	4/4	1	130			:
Hybrd	Zone	6452	MA_4Z_HybPrc4	4/4	1	130			:
Hybrd	Zone	6453	MA_4Z_HybPrc5	4/4	1	130			:
Hybrd	Zone	6454	MA_4Z_HybPrc6	4/4	1	130			:
Hybrd	Zone	6455	MA_4Z_HybPrc7	4/4	1	130			:
Hybrd	Zone	6456	MA_4Z_HybPrc8	4/4	1	90			:
Hybrd	Zone	6457	MA_4Z_HybPrc9	4/4	1	90			:
Hybrd	Zone	6458	MA_4Z_HybPrc10	4/4	1	90			:
Hybrd	Zone	6459	MA_4Z_Ice 1_ES	1/4	4	130			:
Hybrd	Zone	6460	MA_4Z_Ice 2_ES	1/4	8	130			:
Hybrd	Zone	6461	MA_4Z_Ice 3	1/4	4	140			:
Hybrd	Zone	6462	MA_4Z_Ice 4	1/4	8	130			:
Hybrd	Zone	6463	MA_4Z_Ice 5	1/4	8	130			:
Hybrd	Zone	6464	MA_4Z_Ice 6	1/4	8	130			:
Hybrd	Zone	6465	MA_4Z_Ice 7	1/4	8	130			:
Hybrd	Zone	6466	MA_4Z_Ice 8_ES	1/4	8				

Arpeggio Type List

Main Category	Sub Category	ARP No.	ARP Name	Time Signature	Length	Original Tempo	Accent	Random SFX	Voice Type
Hybrd	Zone	6469	MA_4Z_RndmBeat1	4/4	8	90			Syn Comp/Lead/Pad
Hybrd	Zone	6470	MA_4Z_RndmBeat2	4/4	8	90			:
Hybrd	Zone	6471	MA_4Z_RndmBeat3	4/4	2	90			:
Hybrd	Zone	6472	MA_4Z_RndmBeat4	4/4	2	90			:
Hybrd	Zone	6473	MA_4Z_RndmBeat5	4/4	2	90			:
Hybrd	Zone	6474	MA_4Z_RndmBeat6	4/4	8	90			:
Hybrd	Zone	6475	MA_4Z_RndmBeat7	4/4	8	90			:
Hybrd	Zone	6476	MA_4Z_Bend	4/4	1	120			:
Hybrd	Zone	6477	MA_8Z_8ZoneArp 1A	4/4	1	56			:
Hybrd	Zone	6478	MA_8Z_8ZoneArp 1B	4/4	1	56			:
Hybrd	Zone	6479	MA_8Z_8ZoneArp 1C	4/4	1	56			:
Hybrd	Zone	6480	MA_8Z_8ZoneArp 1D	4/4	1	56			:
Hybrd	Zone	6481	MA_8Z_8ZoneArp 1E	4/4	1	56			:
Hybrd	Zone	6482	MA_8Z_8ZoneArpH 1A	4/4	2	112			:
Hybrd	Zone	6483	MA_8Z_8ZoneArpH 1B	4/4	2	112			:
Hybrd	Zone	6484	MA_8Z_8ZoneArpH 1C	4/4	2	112			:
Hybrd	Zone	6485	MA_8Z_8ZoneArpH 1D	4/4	2	112			:
Hybrd	Zone	6486	MA_8Z_8ZoneArpH 1E	4/4	2	112			:
Hybrd	Zone	6487	MA_8Z_8ZoneArp 2A	4/4	1	112			:
Hybrd	Zone	6488	MA_8Z_8ZoneArp 2B	4/4	1	112			:
Hybrd	Zone	6489	MA_8Z_8ZoneArp 2C	4/4	1	112			:
Hybrd	Zone	6490	MA_8Z_8ZoneArp 2D	4/4	1	112			:
Hybrd	Zone	6491	MA_8Z_8ZoneArp 2E	4/4	1	112			:
Hybrd	Zone	6492	MA_8Z_8ZoneArp 3A	4/4	1	140			:
Hybrd	Zone	6493	MA_8Z_8ZoneArp 3B	4/4	1	140			:
Hybrd	Zone	6494	MA_8Z_8ZoneArp 3C	4/4	1	140			:
Hybrd	Zone	6495	MA_8Z_8ZoneArp 3D	4/4	1	140			:
Hybrd	Zone	6496	MA_8Z_8ZoneArp 3E	4/4	1	140			:
Hybrd	Z.Pad	6497	MA_PadL_Pad Seq1	4/4	2	108			:
Hybrd	Z.Pad	6498	MA_PadL_Pad Seq2	4/4	2	104			:
Hybrd	Z.Pad	6499	MA_PadL_Pad Seq3	4/4	2	104			:
Hybrd	Z.Pad	6500	MA_PadL_Pad Seq4	4/4	2	104			:
Hybrd	Z.Pad	6501	MA_PadL_Pad Seq5	4/4	1	108			:
Hybrd	Z.Pad	6502	MA_PadL_Pad Seq6	4/4	2	90			:
Hybrd	Z.Pad	6503	MA_PadL_Pad Seq7	4/4	2	90			:
Hybrd	Z.Pad	6504	MA_PadL_Pad Seq8	4/4	1	90			:
Hybrd	Z.Pad	6505	MA_PadL_Pad Seq9	4/4	1	90			:
Hybrd	Z.Pad	6506	MA_PadL_Pad Seq10	4/4	1	145			:
Hybrd	Z.Pad	6507	MA_PadL_Pad Seq11	4/4	1	130			:
Hybrd	Z.Pad	6508	MA_PadL_Pad Seq12	4/4	2	130			:
Hybrd	Z.Pad	6509	MA_PadL_Pad Seq13	4/4	1	90			:
Hybrd	Z.Pad	6510	MA_PadL_Pad Seq14	4/4	1	90			:
Hybrd	Z.Pad	6511	MA_PadH_Pad Seq1	4/4	1	70			:
Hybrd	Z.Pad	6512	MA_PadH_Pad Seq2	4/4	1	70			:
Hybrd	Z.Pad	6513	MA_PadH_Pad Seq3	4/4	1	70			:
Hybrd	Z.Pad	6514	MA_PadH_Pad Seq4	4/4	1	90			:
Hybrd	Z.Pad	6515	MA_PadH_Pad Seq5	4/4	1	124			:
Hybrd	Z.Pad	6516	MA_PadH_Pad Seq6	4/4	1	56			:
Hybrd	Z.Pad	6517	MA_PadH_Pad Seq7	4/4	2	145			:
Hybrd	Z.Pad	6518	MA_PadH_Pad Seq8	4/4	2	145			:
Hybrd	Z.Pad	6519	MA_PadH_Pad Seq9	4/4	1	145			:
Hybrd	Z.Pad	6520	MA_PadH_Pad Seq10	4/4	2	145			:
Hybrd	Z.Pad	6521	MA_PadH_Pad Seq11	4/4	2	145			:
Hybrd	Z.Pad	6522	MA_PadH_Pad Seq12	4/4	2	145			:
Hybrd	Z.Pad	6523	MA_PadH_Pad Seq13	4/4	2	145			:
Hybrd	Z.Pad	6524	MA_PadH_Pad Seq14	4/4	1	145			:
Hybrd	Z.Pad	6525	MA_PadH_Pad Seq15	4/4	2	145			:
Hybrd	Z.Pad	6526	MA_PadH_Pad Seq16	4/4	2	145			:
Hybrd	Z.Pad	6527	MA_PadH_Pad Seq17	4/4	2	145			:
Hybrd	Z.Pad	6528	MA_PadH_Pad Seq18	4/4	1	145			:
Hybrd	Z.Pad	6529	MA_PadH_Pad Seq19	4/4	1	145			:
Cntr	Filtr	6530	Gate Cut1	4/4	4	120			(CC#10, 71, 74)
Cntr	Filtr	6531	Gate Cut2	4/4	1	120			(CC#74)
Cntr	Filtr	6532	Gate Cut3	4/4	8	120			(CC#71, 74)
Cntr	Filtr	6533	CC-Dive1	4/4	4	130			:
Cntr	Filtr	6534	CC-Dive2	4/4	2	130			:
Cntr	Filtr	6535	FilterWave1	4/4	4	105			:
Cntr	Filtr	6536	FilterWave2	4/4	4	105			:
Cntr	Filtr	6537	Filter 16	4/4	1	153			(CC#74)
Cntr	Filtr	6538	Filter 32	4/4	1	153			:
Cntr	Filtr	6539	Filter 3to3	4/4	2	153			:
Cntr	Filtr	6540	Filter3Delay	4/4	1	153			:
Cntr	Filtr	6541	Filter Fill1	4/4	1	153			:
Cntr	Filtr	6542	Filter Fill2	4/4	1	153			:
Cntr	Filtr	6543	Filter Fill3	4/4	1	153			:
Cntr	Filtr	6544	Filter Fill4	4/4	1	153			:
Cntr	Filtr	6545	MC_Hip Hop 2	4/4	2	94			(CC#71, 74)
Cntr	Filtr	6546	FB_Hip Hop 2	4/4	1	94			:
Cntr	Filtr	6547	MA_Chill Out	4/4	2	79			(CC#74)
Cntr	Filtr	6548	MD_Chill Out	4/4	2	79			(CC#11, 74)
Cntr	Filtr	6549	IA_Chill Out	4/4	4	79			(CC#74)
Cntr	Filtr	6550	FB_Chill Out	4/4	1	79			:
Cntr	Filtr	6551	IA_Trance 5_ES	4/4	4	140			:

Main Category	Sub Category	ARP No.	ARP Name	Time Signature	Length	Original Tempo	Accent	Random SFX	Voice Type
Cntr	Filtr	6552	IA_Dream Dance	4/4	4	136			(CC#74)
Cntr	Filtr	6553	MC_Club House	4/4	2	128			(CC#71, 74)
Cntr	Filtr	6554	FA_Club House	4/4	1	128			(CC#71)
Cntr	Filtr	6555	MB_Garage 2	4/4	2	127			(CC#74)
Cntr	Filtr	6556	MC_Garage 2	4/4	2	127			:
Cntr	Filtr	6557	FA_Garage 2	4/4	1	127			:
Cntr	Exprs	6558	GateL1	4/4	1	134			(CC#11)
Cntr	Exprs	6559	GateL2	4/4	1	134			:
Cntr	Exprs	6560	GateL3	4/4	1	134			:
Cntr	Exprs	6561	GateL4	4/4	1	134			:
Cntr	Exprs	6562	GateL5	4/4	1	134			:
Cntr	Exprs	6563	GateL6	4/4	1	134			:
Cntr	Exprs	6564	GateL7	4/4	1	134			:
Cntr	Exprs	6565	GateL8	4/4	1	134			:
Cntr	Exprs	6566	GateL9	4/4	1	134			:
Cntr	Exprs	6567	GateL10	4/4	1	134			:
Cntr	Exprs	6568	GateL11	4/4	1	134			:
Cntr	Exprs	6569	GateL12	4/4	1	134			:
Cntr	Exprs	6570	GateL13	4/4	1	134			:
Cntr	Exprs	6571	GateL14	4/4	1	134			:
Cntr	Exprs	6572	GateL15	4/4	1	134			:
Cntr	Exprs	6573	GateL16	4/4	1	134			:
Cntr	Exprs	6574	GateL17	4/4	1	134			:
Cntr	Exprs	6575	GateL18	4/4	1	134			:
Cntr	Exprs	6576	GateL19	4/4	1	134			:
Cntr	Exprs	6577	GateL20	4/4	1	134			:
Cntr	Exprs	6578	GateM1	4/4	1	134			:
Cntr	Exprs	6579	GateM2	4/4	1	134			:
Cntr	Exprs	6580	GateM3	4/4	1	134			:
Cntr	Exprs	6581	GateM4	4/4	1	134			:
Cntr	Exprs	6582	GateM5	4/4	1	134			:
Cntr	Exprs	6583	GateM6	4/4	1	134			:
Cntr	Exprs	6584	GateM7	4/4	1	134			:
Cntr	Exprs	6585	GateM8	4/4	1	134			:
Cntr	Exprs	6586	GateM9	4/4	1	134			:
Cntr	Exprs	6587	GateM10	4/4	1	134			:
Cntr	Exprs	6588	GateM11	4/4	1	134			:
Cntr	Exprs	6589	GateM12	4/4	1	134			:
Cntr	Exprs	6590	GateM13	4/4	1	134			:
Cntr	Exprs	6591	GateM14	4/4	1	134			:
Cntr	Exprs	6592	GateM15	4/4	1	134			:
Cntr	Exprs	6593	GateM16	4/4	1	134			:
Cntr	Exprs	6594	GateM17	4/4	1	134			:
Cntr	Exprs	6595	GateM18	4/4	1	134			:
Cntr	Exprs	6596	GateM19	4/4	1	134			:
Cntr	Exprs	6597	GateM20	4/4	1	134			:
Cntr	Exprs	6598	GateS1	4/4	1	134			:
Cntr	Exprs	6599	GateS2	4/4	1	134			:
Cntr	Exprs	6600	GateS3	4/4	1	134			:
Cntr	Exprs	6601	GateS4	4/4	1	134			:
Cntr	Exprs	6602	GateS5	4/4	1	134			:
Cntr	Exprs	6603	GateS6	4/4	1	134			:
Cntr	Exprs	6604	GateS7	4/4	1	134			:
Cntr	Exprs	6605	GateS8	4/4	1	134			:
Cntr	Exprs	6606	GateS9	4/4	1	134			:
Cntr	Exprs	6607	GateS10	4/4	1	134			:
Cntr	Exprs	6608	GateS11	4/4	1	134			:
Cntr	Exprs	6609	GateS12	4/4	1	134			:
Cntr	Exprs	6610	GateS13	4/4	1	134			:
Cntr	Exprs	6611	GateS14	4/4	1	134			:
Cntr	Exprs	6612	GateS15	4/4	1	134			:
Cntr	Exprs	6613	GateS16	4/4	1	134			:
Cntr	Exprs	6614	GateS17	4/4	1	134			:
Cntr	Exprs	6615	GateS18	4/4	1	134			:
Cntr	Exprs	6616	GateS19	4/4	1	134			:
Cntr	Exprs	6617	GateS20	4/4	1	134			:
Cntr	Exprs	6618	LevSawDown	4/4	1	90			:
Cntr	Exprs	6619	SlicePhrase1	4/4	1	153			:
Cntr	Exprs	6620	SlicePhrase2	4/4	1	153			:
Cntr	Exprs	6621	SlicePhrase3	4/4	1	153			:
Cntr	Exprs	6622	SlicePhrase4	4/4	1	153			:
Cntr	Exprs	6623	SlicePhrase5	4/4	4	153			:
Cntr	Exprs	6624	SlicePhrase6	4/4	4	153			:
Cntr	Exprs	6625	SlicePhrase7	4/4	4	153			:
Cntr	Exprs	6626	SlicePhrase8	4/4	4	153			:
Cntr	Exprs	6627	Slice 16	4/4	1	153			:
Cntr	Exprs	6628	Slice 32	4/4	1	155			:
Cntr	Exprs	6629	Slice to3	4/4	1	153			:
Cntr	Exprs	6630	Slice 3Delay	4/4	1	153			:
Cntr	Exprs	6631	Slice Fill1	4/4	1	153			:
Cntr	Exprs	6632	Slice Fill2	4/4	2	153			:
Cntr	Exprs	6633	Slice Fill3	4/4					

Arpeggio Type List

Main Category	Sub Category	ARP No.	ARP Name	Time Signature	Length	Original Tempo	Accent	Random SFX	Voice Type
Cntr	Pan	6635	Pan Etk4CRL	4 / 4	1	153			(CC#10)
Cntr	Pan	6636	Pan Etk4LCR	4 / 4	1	153			:
Cntr	Pan	6637	Pan Etk4RLC	4 / 4	1	153			:
Cntr	Pan	6638	Pan Etk8+LR	4 / 4	1	153			:
Cntr	Pan	6639	Pan Etk16CRL	4 / 4	1	153			:
Cntr	Pan	6640	Pan Etk16RL	4 / 4	1	153			:
Cntr	Pan	6641	Pan Etk16RL>C	4 / 4	1	153			:
Cntr	Pan	6642	Pan 16RL>WRL	4 / 4	2	153			:
Cntr	Pan	6643	MB_Hip Hop 2	4 / 4	2	94			:
Cntr	Pan	6644	MB_New Gospel	4 / 4	2	90			(CC#10, 11)
Cntr	Pan	6645	MC_New Gospel	4 / 4	2	90			:
Cntr	Pan	6646	IA_New Gospel	4 / 4	1	90			:
Cntr	Pan	6647	IA_Club House	4 / 4	2	128			(CC#10)
Cntr	Mod	6648	Mod Control	4 / 4	4	64			(CC#1)
Cntr	Mod	6649	Mod ControlU	4 / 4	4	90			:
Cntr	Pbend	6650	Bend Vibrato	4 / 4	4	120			(PB, PB Range=12)
Cntr	Pbend	6651	BottleDwVib	4 / 4	4	120			:
Cntr	Pbend	6652	BottleUpVib	4 / 4	4	120			:
Cntr	Pbend	6653	HammerVib	4 / 4	4	120			:
Cntr	Pbend	6654	PullingVib1	4 / 4	4	120			:
Cntr	Pbend	6655	PullingVib2	4 / 4	4	120			:
Cntr	Pbend	6656	SlideVibrato	4 / 4	4	120			:
Cntr	Pbend	6657	U/D ChoknVib	4 / 4	4	120			:
Cntr	Pbend	6658	Trill 4	4 / 4	4	120			:
Cntr	Pbend	6659	Trill 5	4 / 4	4	120			:
Cntr	Pbend	6660	Vibrato1	4 / 4	4	120			:
Cntr	Pbend	6661	Vibrato2	4 / 4	4	120			:
Cntr	Pbend	6662	Choking Vib	4 / 4	4	120			:
Cntr	Pbend	6663	Arm Down	4 / 4	4	120			:
Cntr	Pbend	6664	ThrobFx	4 / 4	4	100			(PB, PB Range=24)
Cntr	Pbend	6665	PitchEffect1	4 / 4	1	153			:
Cntr	Pbend	6666	PitchEffect2	4 / 4	1	153			:
Cntr	Pbend	6667	PitchEffect3	4 / 4	1	153			:
Cntr	Pbend	6668	PitchEffect4	4 / 4	1	153			:
Cntr	Pbend	6669	PitchEffect5	4 / 4	1	153			(PB, PB Range=12)
Cntr	Pbend	6670	PitchEffect6	4 / 4	1	153			(PB, PB Range=24)
Cntr	Pbend	6671	PitchEffect7	4 / 4	1	153			:
Cntr	Pbend	6672	PitchEffect8	4 / 4	2	153			:
Cntr	Assign	6673	AS1Env1	4 / 4	1	90			(CC#16)
Cntr	Assign	6674	AS1Env2	4 / 4	1	90			:
Cntr	Assign	6675	AS1Env3	4 / 4	1	90			:
Cntr	Assign	6676	AS1Env4	4 / 4	1	90			:
Cntr	Assign	6677	AS1Env5	4 / 4	1	90			:
Cntr	Assign	6678	AS1Env6	4 / 4	1	90			:
Cntr	Assign	6679	AS1Env7	4 / 4	1	90			:
Cntr	Assign	6680	AS1Env8	4 / 4	1	90			:
Cntr	Assign	6681	AS1Tri+1	4 / 4	1	150			:
Cntr	Assign	6682	AS1Tri-1	4 / 4	1	90			:
Cntr	Assign	6683	AS1TriF1	4 / 4	1	90			:
Cntr	Assign	6684	AS1Tri+4	4 / 4	1	90			:
Cntr	Assign	6685	AS1Tri-4	4 / 4	4	90			:
Cntr	Assign	6686	AS1TriF4	4 / 4	4	90			:
Cntr	Assign	6687	AS1Tri+8	4 / 4	8	90			:
Cntr	Assign	6688	AS1Tri-8	4 / 4	8	90			:
Cntr	Assign	6689	AS1TriF8	4 / 4	8	90			:
Cntr	Assign	6690	AS1Up+1	4 / 4	1	90			:
Cntr	Assign	6691	AS1Dw+1	4 / 4	1	90			:
Cntr	Assign	6692	AS1SawDw	4 / 4	1	90			:
Cntr	Assign	6693	AS2Env1	4 / 4	1	90			(CC#17)
Cntr	Assign	6694	AS2Env2	4 / 4	1	90			:
Cntr	Assign	6695	AS2Env3	4 / 4	1	90			:
Cntr	Assign	6696	AS2Env4	4 / 4	1	90			:
Cntr	Assign	6697	AS2Env5	4 / 4	1	90			:
Cntr	Assign	6698	AS2Env6	4 / 4	1	90			:
Cntr	Assign	6699	AS2Env7	4 / 4	1	90			:
Cntr	Assign	6700	AS2Env8	4 / 4	1	90			:
Cntr	Assign	6701	AS2Tri+1	4 / 4	1	90			:
Cntr	Assign	6702	AS2Tri-1	4 / 4	1	90			:
Cntr	Assign	6703	AS2TriF1	4 / 4	1	90			:
Cntr	Assign	6704	AS2Tri+4	4 / 4	1	90			:
Cntr	Assign	6705	AS2Tri-4	4 / 4	4	90			:
Cntr	Assign	6706	AS2TriF4	4 / 4	4	90			:
Cntr	Assign	6707	AS2Tri+8	4 / 4	1	90			:
Cntr	Assign	6708	AS2Tri-8	4 / 4	8	90			:
Cntr	Assign	6709	AS2TriF8	4 / 4	8	90			:
Cntr	Assign	6710	AS2Up+1	4 / 4	1	90			:
Cntr	Assign	6711	AS2Dw+1	4 / 4	1	90			:
Cntr	Assign	6712	AS2SawDw	4 / 4	1	90			:
Cntr	Genrl	6713	Mute 4/4	4 / 4	1	120			(no event)
Cntr	Genrl	6714	Mute 2/4	2 / 4	1	120			:
Cntr	Genrl	6715	Mute 3/4	3 / 4	1	120			:
Cntr	Genrl	6716	Mute 5/4	5 / 4	1	120			:
Cntr	Genrl	6717	Mute 6/4	6 / 4	1	120			:

Main Category	Sub Category	ARP No.	ARP Name	Time Signature	Length	Original Tempo	Accent	Random SFX	Voice Type
Cntr	Genrl	6718	Mute 6/8	6 / 8	1	120			(no event)
Cntr	Genrl	6719	Mute 3/8	3 / 8	1	120			:
Cntr	Genrl	6720	Mute 9/8	9 / 8	1	120			:

(*contents provided by Keyfax New Media — www.keyfax.com)

Effect Type List

Category	Category (Display)	Effect Type Name	Type (HEX)		MOX6/MOX8					
			MSB	LSB	Rev	Cho	InsA	InsB	InsL	Mas
	—	NO EFFECT	0	0	○	○				
	—	THRU	0	0			○	○	○	
REVERB										
	REV	REV-X HALL	1	0	○					
	REV	R3 HALL	1	1	○					
	REV	SPX HALL	1	2	○	○	○	○		
	REV	REV-X ROOM	1	10	○					
	REV	R3 ROOM	1	11	○					
	REV	SPX ROOM	1	12	○	○	○	○		
	REV	R3 PLATE	1	20	○					
	REV	SPX STAGE	1	30	○	○	○	○		
	REV	SPACE SIMULATOR	1	40	○					
DELAY										
	DLY	CROSS DELAY	2	0		○	○	○		
	DLY	TEMPO CROSS DELAY	2	10		○	○	○		
	DLY	TEMPO DELAY MONO	2	20		○	○	○		
	DLY	TEMPO DELAY STEREO	2	28		○	○	○		
	DLY	CONTROL DELAY	2	30			○	○		
	DLY	DELAY LR	2	40		○	○	○		
	DLY	DELAY LCR	2	50		○	○	○		
	DLY	DELAY LR (Stereo)	2	48		○	○	○		○
CHORUS										
	CHO	G CHORUS	3	0		○	○	○		
	CHO	2 MODULATOR	3	10		○	○	○		
	CHO	SPX CHORUS	3	20		○	○	○		
	CHO	SYMPHONIC	3	30		○	○	○		
	CHO	ENSEMBLE DETUNE	3	40		○	○	○		
FLANGER										
	FLG	VCM FLANGER	4	0		○	○	○		
	FLG	CLASSIC FLANGER	4	10		○	○	○		
	FLG	TEMPO FLANGER	4	20		○	○	○		
	FLG	DYNAMIC FLANGER	4	30			○	○		
PHASER										
	PHA	VCM PHASER MONO	5	0		○	○	○		
	PHA	VCM PHASER STEREO	5	10		○	○	○		
	PHA	TEMPO PHASER	5	20		○	○	○		
	PHA	DYNAMIC PHASER	5	30			○	○		
TOREMOLO&ROTARY										
	T&R	AUTO PAN	6	0			○	○		
	T&R	TREMOLO	6	10			○	○		
	T&R	ROTARY SPEAKER	6	20			○	○		
DISTORTION										
	DST	AMP SIMULATOR 1	7	0			○	○		
	DST	AMP SIMULATOR 2	7	10			○	○		
	DST	COMP DISTORTION	7	20			○	○		
	DST	COMP DISTORTION DELAY	7	30			○	○		○
COMPRESSOR										
	CMP	VCM COMPRESSOR 376	8	0			○	○		○
	CMP	CLASSIC COMPRESSOR	8	10			○	○		
	CMP	MULTI BAND COMP	8	20			○	○		○
WAH										
	WAH	VCM AUTO WAH	0A	0			○	○		
	WAH	VCM TOUCH WAH	0A	10			○	○		
	WAH	VCM PEDAL WAH	0A	20			○	○		
LO-FI										
	L-F	LO-FI	0B	0			○	○		○
	L-F	NOISY	0B	10			○	○		
	L-F	DIGITAL TURNTABLE	0B	20			○	○		
TECH										
	TEC	RING MODULATOR	0C	0			○	○		○
	TEC	DYNAMIC RING MODULATOR	0C	10			○	○		
	TEC	DYNAMIC FILTER	0C	20			○	○		○
	TEC	AUTO SYNTH	0C	30			○	○		
	TEC	ISOLATOR	0C	40			○	○		○
	TEC	SLICE	0C	50			○	○		○
	TEC	TECH MODULATION	0C	60			○	○		
MISC										
	MSC	VCM EQ 501	0D	0			○	○		
	MSC	HARMONIC ENHANCER	0D	10			○	○		
	MSC	TALKING MODULATOR	0D	20			○	○		
	MSC	DAMPER RESONANCE	0D	30			○	○		
	MSC	PITCH CHANGE	0D	40			○	○		
	MSC	EARLY REFLECTION	0D	50		○	○	○		
	MSC	VOCODER	0D	60					○	
	MSC	NOISE GATE+COMP+EQ	0D	70			○	○		

Effect Parameter List

Reverb Block

[0] NO EFFECT

When this type is selected, no parameters are available.

[1] REV-X HALL [4] REV-X ROOM

No.	Parameter	Range	Value	Table No.
1	Reverb Time	0.3s – 18.0s (HALL)/ 10.0s (ROOM)	(0 – 69)	23/24
2	Diffusion	0 – 10	(0 – 10)	
3	Initial Delay	0.1ms – 200.0ms	(0 – 127)	5
4	HPF Cutoff Frequency	20Hz – 8.0kHz	(0 – 52)	3
5	LPF Cutoff Frequency	1.0kHz – 20.0kHz	(34 – 60)	3
6	Room Size	0 – 31	(0 – 31)	
7	High Ratio	0.1 – 1.0	(1 – 10)	
8	Low Ratio	0.1 – 1.4	(1 – 14)	
9	Decay	0 – 63	(0 – 63)	
10	—			
11	—			
12	—			
13	—			
14	—			
15	—			
16	—			

REV-X HALL: (Table No.23)

REV-X ROOM: (Table No.24)

For details, refer to the Effect Data Assign Table.

[2] R3 HALL [3] SPX HALL [5] R3 ROOM [6] SPX ROOM [7] R3 PLATE [8] SPX STAGE

No.	Parameter	Range	Value	Table No.
1	Reverb Time	0.3s – 30.0s	(0 – 69)	4
2	Diffusion	0 – 10	(0 – 10)	
3	Initial Delay	0.1ms – 200.0ms	(0 – 127)	5
4	HPF Cutoff Frequency	20Hz – 8.0kHz	(0 – 52)	3
5	LPF Cutoff Frequency	1.0kHz – 20.0kHz	(34 – 60)	3
6	—			
7	—			
8	—			
9	—			
10	—			
11	Reverb Delay	0.1ms – 200.0ms	(0 – 127)	5
12	Density	0 – 4	(0 – 4)	
13	ER/Rev Balance	E63>R – E=R – E<R63	(1 – 127)	
14	Feedback High Damp	0.1 – 1.0	(1 – 10)	
15	Feedback Level	-63 – +63	(1 – 127)	
16	—			

[9] SPACE SIMULATOR

No.	Parameter	Range	Value	Table No.
1	Reverb Time	0.3s – 30.0s	(0 – 69)	4
2	Diffusion	0 – 10	(0 – 10)	
3	Initial Delay	0.1ms – 200.0ms	(0 – 127)	5
4	HPF Cutoff Frequency	20Hz – 8.0kHz	(0 – 52)	3
5	LPF Cutoff Frequency	1.0kHz – 20.0kHz	(34 – 60)	3
6	Width	0.5m – 30.2m	(0 – 104)	11
7	Height	0.5m – 30.2m	(0 – 104)	11
8	Depth	0.5m – 30.2m	(0 – 104)	11
9	Wall Vary	0 – 30	(0 – 30)	
10	—			
11	Reverb Delay	0.1ms – 200.0ms	(0 – 127)	5
12	Density	0 – 4	(0 – 4)	
13	ER/Rev Balance	E63>R – E=R – E<R63	(1 – 127)	
14	Feedback High Damp	0.1 – 1.0	(1 – 10)	
15	Feedback Level	-63 – +63	(1 – 127)	
16	Space Type	0 – 1	(0 – 1)	

Chorus, Insertion Block

[0] THRU/NO EFFECT

When this type is selected, no parameters are available.

Category — REVERB

[1] SPX HALL [2] SPX ROOM [3] SPX STAGE

No.	Parameter	Range	Value	Table No.
1	Reverb Time	0.3s – 30.0s	(0 – 69)	4
2	Diffusion	0 – 10	(0 – 10)	
3	Initial Delay	0.1ms – 99.3ms	(0 – 63)	5
4	HPF Cutoff Frequency	20Hz – 8.0kHz	(0 – 52)	3
5	LPF Cutoff Frequency	1.0kHz – 20.0kHz	(34 – 60)	3
6	—			
7	—			
8	—			
9	—			
10	Dry/Wet Balance	D63>W – D=W – D<W63	(1 – 127)	
11	Reverb Delay	0.1ms – 99.3ms	(0 – 63)	5
12	Density	0 – 4	(0 – 4)	
13	ER/Rev Balance	E63>R – E=R – E<R63	(1 – 127)	
14	Feedback High Damp	0.1 – 1.0	(1 – 10)	
15	Feedback Level	-63 – +63	(1 – 127)	
16	—			

Category — DELAY

[1] CROSS DELAY

No.	Parameter	Range	Value	Table No.
1	Delay Time L>R	0.1ms – 1638.3ms	(1 – 16383)	
2	Delay Time R>L	0.1ms – 1638.3ms	(1 – 16383)	
3	Feedback Level	-63 – +63	(1 – 127)	
4	Input Select	L, R, L&R	(0 – 2)	
5	Feedback High Damp	0.1 – 1.0	(1 – 10)	
6	—			
7	—			
8	—			
9	—			
10	Dry/Wet Balance	D63>W – D=W – D<W63	(1 – 127)	
11	—			
12	—			
13	EQ Low Frequency	32Hz – 2.0kHz	(4 – 40)	3
14	EQ Low Gain	-12dB – +12dB	(52 – 76)	
15	EQ High Frequency	500Hz – 16.0kHz	(28 – 58)	3
16	EQ High Gain	-12dB – +12dB	(52 – 76)	

[2] TEMPO CROSS DELAY

No.	Parameter	Range	Value	Table No.
1	Delay Time L>R	32nd/3 – 4thx6	(0 – 19)	13
2	Delay Time R>L	32nd/3 – 4thx6	(0 – 19)	13
3	Feedback Level	-63 – +63	(1 – 127)	
4	Input Select	L, R, L&R	(0 – 2)	
5	Feedback High Damp	0.1 – 1.0	(1 – 10)	
6	Lag	-63ms – +63ms	(1 – 127)	
7	—			
8	—			
9	—			
10	Dry/Wet Balance	D63>W – D=W – D<W63	(1 – 127)	
11	—			
12	—			

13 – 16: Same as the parameters shaded in gray in CROSS DELAY above.

[3] TEMPO DELAY MONO

No.	Parameter	Range	Value	Table No.
1	Delay Time	32nd/3 – 4thx6	(0 – 19)	13
2	Feedback Level	-63 – +63	(1 – 127)	
3	Feedback High Damp	0.1 – 1.0	(1 – 10)	
4	L/R Diffusion	-63ms – +63ms	(1 – 127)	
5	Lag	-63ms – +63ms	(1 – 127)	
6	—			
7	—			
8	—			
9	—			
10	Dry/Wet Balance	D63>W – D=W – D<W63	(1 – 127)	
11	—			
12	—			

13 – 16: Same as the parameters shaded in gray in CROSS DELAY above.

[4] TEMPO DELAY STEREO

No.	Parameter	Range	Value	Table No.
1	Delay Time	32nd/3 – 4thx6	(0 – 19)	13
2	Feedback Level	-63 – +63	(1 – 127)	
3	Feedback High Dump	0.1 – 1.0	(1 – 10)	
4	L/R Diffusion	-63ms – +63ms	(1 – 127)	
5	Lag	-63ms – +63ms	(1 – 127)	
6	—			
7	—			
8	—			
9	—			
10	Dry/Wet Balance	D63>W – D=W – D<W63	(1 – 127)	
11	—			
12	—			

13 – 16: Same as the parameters shaded in gray in CROSS DELAY on page 79.

[5] CONTROL DELAY

No.	Parameter	Range	Value	Table No.
1	Delay Time	0.1ms – 1486.0ms	(1 – 14860)	
2	Delay transition rate	1 – 48	(1 – 48)	
3	Feedback Level	-63 – +63	(1 – 127)	
4	Feedback High Dump	0.1 – 1.0	(1 – 10)	
5	—			
6 – 9	Same as the parameters shaded in gray in CROSS DELAY on page 79.			
10	Dry/Wet Balance	D63>W – D=W – D<W63	(1 – 127)	
11	Control Type	Normal, Scratch	(0 – 1)	
12	—			
13	—			
14	—			
15	—			
16	—			

[6] DELAY L, R

No.	Parameter	Range	Value	Table No.
1	Delay Time L	0.1ms – 1638.3ms	(1 – 16383)	
2	Delay Time R	0.1ms – 1638.3ms	(1 – 16383)	
3	Feedback Time 1	0.1ms – 1638.3ms	(1 – 16383)	
4	Feedback Time 2	0.1ms – 1638.3ms	(1 – 16383)	
5	Feedback Level	-63 – +63	(1 – 127)	
6	Feedback High Dump	0.1 – 1.0	(1 – 10)	
7	—			
8	—			
9	—			
10	Dry/Wet Balance	D63>W – D=W – D<W63	(1 – 127)	
11	—			
12	—			

13 – 16: Same as the parameters shaded in gray in CROSS DELAY on page 79.

[7] DELAY L, C, R

No.	Parameter	Range	Value	Table No.
1	Delay Time L	0.1ms_1638.3ms	(1 – 16383)	
2	Delay Time R	0.1ms_1638.3ms	(1 – 16383)	
3	Delay Time C	0.1ms_1638.3ms	(1 – 16383)	
4	Feedback Time	0.1ms_1638.3ms	(1 – 16383)	
5	Feedback Level	-63 – +63	(1 – 127)	
6	Delay Level C	0 – 127	(0 – 127)	
7	Feedback High Dump	0.1 – 1.0	(1 – 10)	
8	—			
9	—			
10	Dry/Wet Balance	D63>W – D=W – D<W63	(1 – 127)	
11	—			
12	—			

13 – 16: Same as the parameters shaded in gray in CROSS DELAY on page 79.

[8] DELAY L, R (STEREO)

No.	Parameter	Range	Value	Table No.
1	Delay Time L	0.1ms – 1638.3ms	(1 – 16383)	
2	Delay Time R	0.1ms – 1638.3ms	(1 – 16383)	
3	Feedback Time L	0.1ms – 1638.3ms	(1 – 16383)	
4	Feedback Time R	0.1ms – 1638.3ms	(1 – 16383)	
5	Feedback Level	-63 – +63	(1 – 127)	
6	Feedback High Dump	0.1 – 1.0	(1 – 10)	
7	—			
8	—			
9	—			
10	Dry/Wet Balance	D63>W – D=W – D<W63	(1 – 127)	
11	—			
15	—			

13 – 16: Same as the parameters shaded in gray in CROSS DELAY on page 79.

Category — CHORUS

[1] G CHORUS

No.	Parameter	Range	Value	Table No.
1	LFO Speed	0.0Hz – 39.70Hz	(0 – 127)	1
2	—			
3	PM Depth	0 – 127	(0 – 127)	
4	Feedback Level	-63 – +63	(1 – 127)	
5	Delay Offset	0.0ms – 50.0ms	(0 – 127)	2
6 – 9	Same as the parameters shaded in gray in CROSS DELAY on page 79.			
10	Dry / Wet Balance	D63>W – D=W – D<W63	(1 – 127)	
11	EQ Mid Frequency	100Hz – 10.0kHz	(14 – 54)	3
12	EQ Mid Gain	-12dB – +12dB	(52 – 76)	
13	EQ Mid Width	0.1 – 12.0	(1 – 120)	
14	—			
15	Input Mode	Mono, Stereo	(0 – 1)	
16	—			

[2] 2 MODULATOR

No.	Parameter	Range	Value	Table No.
1	LFO Speed	0.0Hz – 39.70Hz	(0 – 127)	1
2	AM Depth	0 – 127	(0 – 127)	
3	PM Depth	0 – 127	(0 – 127)	
4	Feedback Level	-63 – +63	(1 – 127)	
5	Delay Offset	0.0ms – 50.0ms	(0 – 127)	2
6 – 9	Same as the parameters shaded in gray in CROSS DELAY on page 79.			
10	Dry / Wet Balance	D63>W – D=W – D<W63	(1 – 127)	
11	EQ Mid Frequency	100Hz – 10.0kHz	(14 – 54)	3
12	EQ Mid Gain	-12dB – +12dB	(52 – 76)	
13	EQ Mid Width	0.1 – 12.0	(1 – 120)	
14	—			
15	Input Mode	Mono, Stereo	(0 – 1)	
16	—			

[3] SPX CHORUS

No.	Parameter	Range	Value	Table No.
1	LFO Speed	0.0Hz – 39.70Hz	(0 – 127)	1
2	LFO Depth	0 – 127	(0 – 127)	
3	Feedback Level	-63 – +63	(1 – 127)	
4	Delay Offset	0.0ms – 50.0ms	(0 – 127)	2
5	—			
6 – 9	Same as the parameters shaded in gray in CROSS DELAY on page 79.			
10	Dry/Wet Balance	D63>W – D=W – D<W63	(1 – 127)	
11	EQ Mid Frequency	100Hz – 10.0kHz	(14 – 54)	3
12	EQ Mid Gain	-12dB – +12dB	(52 – 76)	
13	EQ Mid Width	0.1 – 12.0	(1 – 120)	
14	—			
15	Input Mode	Mono, Stereo	(0 – 1)	
16	—			

[4] SYMPHONIC

No.	Parameter	Range	Value	Table No.
1	LFO Speed	0.0Hz – 39.70Hz	(0 – 127)	1
2	LFO Depth	0 – 127	(0 – 127)	
3	Delay Offset	0.0ms – 50.0ms	(0 – 127)	2
4	—			
5	—			
6 – 9: Same as the parameters shaded in gray in CROSS DELAY on page 79.				
10	Dry/Wet Balance	D63>W – D=W – D<W63	(1 – 127)	
11	EQ Mid Frequency	100Hz – 10.0kHz	(14 – 54)	3
12	EQ Mid Gain	-12dB – +12dB	(52 – 76)	
13	EQ Mid Width	0.1 – 12.0	(1 – 120)	
14	—			
15	—			
16	—			

[5] ENSEMBLE DETUNE

No.	Parameter	Range	Value	Table No.
1	Detune	-50cent – +50cent	(14 – 114)	
2	Initial Delay Lch	0.0ms – 50.0ms	(0 – 127)	2
3	Initial Delay Rch	0.0ms – 50.0ms	(0 – 127)	2
4	Spread	0 – 63	(0 – 63)	
5	—			
6	—			
7	—			
8	—			
9	—			
10	Dry/Wet Balance	D63>W – D=W – D<W63	(1 – 127)	
11 – 14: Same as the parameters shaded in gray in CROSS DELAY on page 79.				
15	—			
16	—			

Category — FLANGER

[1] VCM FLANGER

No.	Parameter	Range	Value	Table No.
1	Speed	0.040Hz – 10.00Hz	(0 – 235)	20
2	Manual	0 – 127	(0 – 127)	
3	Depth	0 – 127	(0 – 127)	
4	Feedback	0 – 127	(0 – 127)	
5	Type	1 – 3	(0 – 2)	
6	Spread	0 – 127	(0 – 127)	
7	Mix	0 – 127	(0 – 127)	
8	—			
9	—			
10	—			
11	—			
12	—			
13	—			
14	—			
15	—			
16	—			

[2] CLASSIC FLANGER

No.	Parameter	Range	Value	Table No.
1	LFO Speed	0.0Hz – 39.70Hz	(0 – 127)	1
2	LFO Depth	0 – 127	(0 – 127)	
3	LFO Wave	Triangle, Sine, Random	(0 – 2)	
4	Delay Offset	0.09 – 36.21ms	(0 – 139)	18
5	Feedback Level	-100 – +100%	(0 – 200)	
6 – 9: Same as the parameters shaded in gray in CROSS DELAY on page 79.				
10	Dry/Wet Balance	D63>W – D=W – D<W63	(1 – 127)	
11	EQ Mid Frequency	100Hz – 10.0kHz	(14 – 54)	3
12	EQ Mid Gain	-12dB – +12dB	(52 – 76)	
13	EQ Mid Width	0.1 – 12.0	(1 – 120)	
14	Modulation Phase	-180 – +180	(0 – 16)	19
15	Feedback High Damp	0.1 – 1.0	(1 – 10)	
16	Analog Feel	0 – 10	(0 – 10)	

[3] TEMPO FLANGER

No.	Parameter	Range	Value	Table No.
1	LFO Speed	16th – 4thx16	(5 – 29)	13
2	LFO Depth	0 – 127	(0 – 127)	
3	Feedback Level	-63 – +63	(1 – 127)	
4	Delay Offset	0.0ms – 50.0ms	(0 – 127)	2
5	LFO Phase Reset	Off (free run), Key On Reset, SEQ Start Reset	(0 – 2)	
6 – 9: Same as the parameters shaded in gray in CROSS DELAY on page 79.				
10	Dry/Wet Balance	D63>W – D=W – D<W63	(1 – 127)	
11	EQ Mid Frequency	100Hz – 10.0kHz	(14 – 54)	3
12	EQ Mid Gain	-12dB – +12dB	(52 – 76)	
13	EQ Mid Width	0.1 – 12.0	(1 – 120)	
14	LFO Phase Difference	-180deg – +180deg	(4 – 124)	
15	—			
16	—			

[4] DYNAMIC FLANGER

No.	Parameter	Range	Value	Table No.
1	Sensitivity	0 – 127	(0 – 127)	
2	Delay Offset	0 – 127	(0 – 127)	
3	Feedback Level	-63 – +63	(1 – 127)	
4	Attack Time	0.3ms – 227ms	(0 – 127)	15
5	Release Time	2.6ms – 2171ms	(0 – 127)	16
6	Release Curve	0 – 127	(0 – 127)	
7	Direction	Up, Down	(0 – 1)	
8	Dyna Threshold Level	0 – 127	(0 – 127)	
9	Dyna Level Offset	0 – 127	(0 – 127)	
10	Dry/Wet Balance	D63>W – D=W – D<W63	(1 – 127)	
11	—			
12	—			
13 – 16: Same as the parameters shaded in gray in CROSS DELAY on page 79.				

Category — PHASER

[1] VCM PHASER MONO

No.	Parameter	Range	Value	Table No.
1	Speed	0.100Hz – 10.00Hz	(0 – 252)	21
2	Manual	0 – 127	(0 – 127)	
3	Depth	0 – 127	(0 – 127)	
4	Feedback	0 – 127	(0 – 127)	
5	Stage	4, 6, 8, 10, 12, 16	(0 – 5)	
6	Mode	1, 2, 3	(0 – 2)	
7	Color	0 – 127	(0 – 127)	
8	—			
9	—			
10	—			
11	—			
12	—			
13	—			
14	—			
15	—			
16	—			

The Color parameter is not available in the following conditions: When Mode is set to 1 and Stage is set to 4, 6, 8, 12 or 16; or when Mode is set to 2 and Stage is set to 4 or 10.

[2] VCM PHASER STEREO

No.	Parameter	Range	Value	Table No.
1	Speed	0.100Hz – 10.00Hz	(0 – 252)	21
2	Manual	0 – 127	(0 – 127)	
3	Depth	0 – 127	(0 – 127)	
4	Feedback	0 – 127	(0 – 127)	
5	Stage	4, 6, 8, 10	(0 – 3)	
6	Mode	1, 2	(0 – 1)	
7	Color	0 – 127	(0 – 127)	
8	Spread	0 – 127	(0 – 127)	
9	—			
10	—			
11	—			
12	—			
13	—			
14	—			
15	—			
16	—			

The Color parameter is not available in the following conditions: When Mode is set to 1 and Stage is set to 4, 6, or 8; or when Mode is set to 2 and Stage is set to 4 or 10.

[3] TEMPO PHASER

No.	Parameter	Range	Value	Table No.
1	LFO Speed	16th – 4thx16	(5 – 29)	13
2	LFO Depth	0 – 127	(0 – 127)	
3	Phase Shift Offset	0 – 127	(0 – 127)	
4	Feedback Level	-63 – +63	(1 – 127)	
5	LFO Phase Reset	Off (free run), Key On Reset, SEQ Start Reset	(0 – 2)	
6 – 9: Same as the parameters shaded in gray in CROSS DELAY on page 79.				
10	Dry/Wet Balance	D63>W – D=W – D<W63	(1 – 127)	
11	Stage	4 – 22	(4 – 22)	
12	Diffusion	Mono, Stereo	(0 – 1)	
13	—			
14	—			
15	—			
16	—			

[4] DYNAMIC PHASER

No.	Parameter	Range	Value	Table No.
1	Sensitivity	0 – 127	(0 – 127)	
2	Dyna Level Offset	0 – 127	(0 – 127)	
3	Feedback Level	-63 – +63	(1 – 127)	
4	Attack Time	0.3ms – 227ms	(0 – 127)	15
5	Release Time	2.6ms – 2171ms	(0 – 127)	16
6	Release Curve	0 – 127	(0 – 127)	
7	Direction	Up, Down	(0 – 1)	
8	Dyna Threshold Level	0 – 127	(0 – 127)	
9	—			
10	Dry/Wet Balance	D63>W – D=W – D<W63	(1 – 127)	
11	Stage	4, 5, 6	(4 – 6)	
12	—			
13 – 16: Same as the parameters shaded in gray in CROSS DELAY on page 79.				

Category — TREMOLO&ROTARY**[1] AUTO PAN**

No.	Parameter	Range	Value	Table No.
1	LFO Speed	0.0Hz – 39.70Hz	(0 – 127)	1
2	L/R Depth	0 – 127	(0 – 127)	
3	F/R Depth	0 – 127	(0 – 127)	
4	PAN Direction	L<>R, L>>R, L<<R, Lturn, Rturn, L/R	(0 – 5)	
5	LFO Wave	0 – 28	(0 – 28)	
6 – 9: Same as the parameters shaded in gray in CROSS DELAY on page 79.				
10	—			
11	EQ Mid Frequency	100Hz – 10.0kHz	(14 – 54)	3
12	EQ Mid Gain	-12dB – +12dB	(52 – 76)	
13	EQ Mid Width	0.1 – 12.0	(1 – 120)	
14	—			
15	Input Mode	Mono, Stereo	(0 – 1)	
16	—			

[2] TREMOLO

No.	Parameter	Range	Value	Table No.
1	LFO Speed	0.0Hz – 39.70Hz	(0 – 127)	1
2	AM Depth	0 – 127	(0 – 127)	
3	PM Depth	0 – 127	(0 – 127)	
4	—			
5	—			
6 – 9: Same as the parameters shaded in gray in CROSS DELAY on page 79.				
10	—			
11	EQ Mid Frequency	100Hz – 10.0kHz	(14 – 54)	3
12	EQ Mid Gain	-12dB – +12dB	(52 – 76)	
13	EQ Mid Width	0.1 – 12.0	(1 – 120)	
14	LFO Phase difference	-180deg – +180deg	(4 – 124)	
15	Input Mode	Mono, Stereo	(0 – 1)	
16	—			

[3] ROTARY SPEAKER

No.	Parameter	Range	Value	Table No.
1	Rotor Speed Slow	0.0Hz – 2.65Hz	(0 – 63)	1
2	Horn Speed Slow	0.0Hz – 2.65Hz	(0 – 63)	1
3	Rotor Speed Fast	0.0Hz – 39.70Hz	(64 – 127)	1
4	Horn Speed Fast	0.0Hz – 39.70Hz	(64 – 127)	1
5	Slow-Fast Time of Rotor	0 – 127	(0 – 127)	
6	Slow-Fast Time of Horn	0 – 127	(0 – 127)	
7	Drive Rotor	0 – 127	(0 – 127)	
8	Drive Horn	0 – 127	(0 – 127)	
9	Rotor/Horn Balance	R63>H – R=H – R<H63	(1 – 127)	
10	—			
11 – 14: Same as the parameters shaded in gray in CROSS DELAY on page 79.				
15	Mic L-R Angle	0deg – 180deg	(0 – 60)	
16	Speed Control	Slow, Fast	(0 – 1)	

Category — DISTORTION**[1] AMP SIMULATOR 1**

No.	Parameter	Range	Value	Table No.
1	Overdrive	0 – 100%	(0 – 100)	
2	Device	Transistor, Vintage Tube, Distortion 1, Distortion 2, Fuzz	(0 – 4)	
3	Speaker Type	Flat, Stack, Combo, Twin, Radio, Megaphone	(0 – 5)	
4	Presence	-10 – 10	(0 – 20)	
5	Output Level	0 – 100%	(0 – 100)	
6	—			
7	—			
8	—			
9	—			
10	Dry/Wet Balance	D63>W _ D=W _ D<W63	(1 – 127)	
11	—			
12	—			
13	—			
14	—			
15	—			
16	—			

[2] AMP SIMULATOR 2

No.	Parameter	Range	Value	Table No.
1	Overdrive	0 – 127	(0 – 127)	
2	AMP Type	Off, Stack, Combo, Tube, Crunch, Hi Gain, British	(0 – 6)	
3	LPF Cutoff Frequency	1.0kHz – 20.0kHz	(34 – 60)	3
4	Output Level	0 – 127	(0 – 127)	
5	—			
6	—			
7	—			
8	—			
9	—			
10	Dry/Wet Balance	D63>W – D=W – D<W63	(1 – 127)	
11	—			
12	—			
13	—			
14	—			
15	—			
16	—			

[3] COMP DISTORTION

No.	Parameter	Range	Value	Table No.
1	Overdrive	0 – 127	(0 – 127)	
2	EQ Low Frequency	32Hz – 2.0kHz	(4 – 40)	3
3	EQ Low Gain	-12dB – +12dB	(52 – 76)	
4	LPF Cutoff Frequency	1.0kHz – 20.0kHz	(34 – 60)	3
5	Output Level	0 – 127	(0 – 127)	
6	—			
7	EQ Mid Frequency	100Hz – 10.0kHz	(14 – 54)	3
8	EQ Mid Gain	-12dB – +12dB	(52 – 76)	
9	EQ Mid Width	0.1 – 12.0	(1 – 120)	
10	Dry / Wet Balance	D63>W – D=W – D<W63	(1 – 127)	
11	Edge	0 – 127	(0 – 127)	
12	Attack	1ms – 40ms	(0 – 19)	8
13	Release	10ms – 680ms	(0 – 15)	9
14	Threshold	-48dB – -6dB	(79 – 121)	
15	Ratio	1 – 20.0	(0 – 7)	10
16	—			

[3] COMP DISTORTION DELAY

No.	Parameter	Range	Value	Table No.
1	Overdrive	0 – 100%	(0 – 100)	
2	Device	Transistor, Vintage Tube, Distortion 1, Distortion 2, Fuzz	(0 – 4)	
3	Speaker Type	Flat, Stack, Combo, Twin, Radio, Megaphone	(0 – 5)	
4	Presence	-10 – 10	(0 – 20)	
5	Output Level	0 – 100%	(0 – 100)	
6	Delay Time L	0.1ms – 1638.3ms	(1 – 16383)	
7	Delay Time R	0.1ms – 1638.3ms	(1 – 16383)	
8	Feedback Time	0.1ms – 1638.3ms	(1 – 16383)	
9	Feedback Level	-63 – +63	(1 – 127)	
10	Dry/Wet Balance	D63>W – D=W – D<W63	(1 – 127)	
11	Delay Mix	0 – 127	(0 – 127)	
12	Feedback High Damp	0.1 – 1.0	(1 – 10)	
13	Compress	-48dB – -6dB	(79 – 121)	
14	—			
15	—			
16	—			

Category — COMPRESSOR

[1] VCM COMPRESSOR 376

No.	Parameter	Range	Value	Table No.
1	Input Level	-∞ – 0.00dB	(0 – 200)	25
2	Output Level	-∞ – 0.00dB	(0 – 200)	25
3	Ratio	2, 4, 8, 12, 20	(0 – 4)	
4	Attack	0.022ms – 50.40ms	(0 – 200)	26
5	Release	10.88ms – 544.22ms	(0 – 200)	27
6	Meter	OUT, GR	(0 – 1)	
7	—			
8	—			
9	—			
10	—			
11	—			
12	—			
13	—			
14	—			
15	—			
16	—			

[2] CLASSIC COMPRESSOR

No.	Parameter	Range	Value	Table No.
1	Attack	1ms – 40ms	(0 – 19)	8
2	Release	10ms – 680ms	(0 – 15)	9
3	Threshold	-48dB – -6dB	(79 – 121)	
4	Ratio	1 – 20.0	(0 – 7)	10
5	Output Level	0 – 127	(0 – 127)	
6	—			
7	—			
8	—			
9	—			
10	—			
11	—			
12	—			
13	—			
14	—			
15	—			
16	—			

[3] MULTI BAND COMP

No.	Parameter	Range	Value	Table No.
1	Low Attack	1ms – 200ms	(0 – 29)	8
2	Low Threshold	-54dB – -6dB	(73 – 121)	
3	Low Ratio	1 – 20.0	(0 – 7)	10
4	Low Gain	-∞ – +18dB	(0 – 55)	14
5	Mid Attack	1ms – 200ms	(0 – 29)	8
6	Mid Threshold	-54dB – -6dB	(73 – 121)	
7	Mid Ratio	1 – 20.0	(0 – 7)	10
8	Mid Gain	-∞ – +18dB	(0 – 55)	14
9	High Attack	1ms – 200ms	(0 – 29)	8
10	High Threshold	-54dB – -6dB	(73 – 121)	
11	High Ratio	1 – 20.0	(0 – 7)	10
12	High Gain	-∞ – +18dB	(0 – 55)	14
13	Divide Freq Low	16Hz – 20kHz	(0 – 124)	28
14	Divide Freq High	16Hz – 20kHz	(0 – 124)	28
15	Common Release	10msec – 3000msec	(0 – 23)	9
16	—			

Category — WAH

[1] VCM AUTO WAH

No.	Parameter	Range	Value	Table No.
1	Speed	0.100Hz – 20.00Hz	(0 – 254)	22
2	Bottom	0 – 127	(0 – 127)	
3	Top	0 – 127	(0 – 127)	
4	Resonance Offset	-12.0 – +12.0	(40 – 88)	
5	LFO Wave	Sin, Trp	(0 – 1)	
6	Type	High, Mid, Low, Bass	(0 – 3)	
7	Overdrive	0.0dB – +40.0dB	(0 – 80)	
8	Output	-20.0dB – +10.0dB	(24 – 84)	
9	—			
10	—			
11	—			
12	—			
13	—			
14	—			
15	—			
16	—			

When the value of Bottom is greater than Top, the sound will not be modulated and only the Bottom value is available.

[2] VCM TOUCH WAH

No.	Parameter	Range	Value	Table No.
1	Sensitivity	0 – 127	(0 – 127)	
2	Bottom	0 – 127	(0 – 127)	
3	Top	0 – 127	(0 – 127)	
4	Resonance Offset	-12.0 – +12.0	(40 – 88)	
5	Direction	Up, Down	(0 – 1)	
6	Type	High, Mid, Low, Bass	(0 – 3)	
7	Overdrive	0.0dB – +40.0dB	(0 – 80)	
8	Output	-20.0dB – +10.0dB	(24 – 84)	
9	—			
10	—			
11	Attack Offset	-5 – +5	(59 – 69)	
12	—			
13	—			
14	—			
15	—			
16	—			

When the value of Bottom is greater than Top, the sound will not be modulated and only the Bottom value is available.

[3] VCM PEDAL WAH

No.	Parameter	Range	Value	Table No.
1	Pedal Control	0 – 127	(0 – 127)	
2	Bottom	0 – 127	(0 – 127)	
3	Top	0 – 127	(0 – 127)	
4	Resonance Offset	-12.0 – +12.0	(40 – 88)	
5	Direction	Up, Down	(0 – 1)	
6	Type	High, Mid, Low, Bass	(0 – 3)	
7	Overdrive	0.0dB – +40.0dB	(0 – 80)	
8	Output	-20.0dB – +10.0dB	(24 – 84)	
9	—			
10	—			
11	—			
12	—			
13	—			
14	—			
15	—			
16	—			

When the value of Bottom is greater than Top, the sound will not be modulated and only the Bottom value is available.

Category — Lo-Fi

[1] LO-FI

No.	Parameter	Range	Value	Table No.
1	Sampling Freq. Control	44.1 – 344Hz	(0 – 127)	12
2	Word Length	1 – 127	(1 – 127)	
3	Output Gain	-6dB – +36dB	(0 – 42)	
4	Pre-LPF Cutoff Frequency	63Hz – 20.0kHz	(10 – 60)	3
5	Filter Type	Thru, Power Bass, Radio, Telephone, Clean, Low	(0 – 5)	
6	Pre-LPF Resonance	1 – 12.0	(10 – 120)	
7	Bit Assign	0 – 6	(0 – 6)	
8	Emphasis	Off/On	(0 – 1)	
9	—			
10	Dry/Wet Balance	D63>W – D=W – D<W63	(1 – 127)	
11	—			
12	—			
13	—			
14	—			
15	Input Mode	Mono, Stereo	(0 – 1)	
16	—			

[2] NOISY

No.	Parameter	Range	Value	Table No.
1	Mod Depth	0 – 10	(0 – 10)	
2	Mod Speed	0 – 127	(0 – 127)	
3	Mod Feedback	-63 – +63	(1 – 127)	
4	Mod Mix Balance	1 – 127	(1 – 127)	
5	Drive	0 – 127	(0 – 127)	
6	AM Speed	0.00Hz – 39.7Hz	(0 – 127)	1
7	AM Depth	0 – 127	(0 – 127)	
8	LPF Cutoff Frequency	1.0kHz – 20.0kHz	(34 – 60)	3
9	LPF Resonance	1.0 – 12.0	(10 – 120)	
10	Dry/Wet Balance	D63>W – D=W – D<W63	(1 – 127)	
11	EQ Frequency	100Hz – 10.0kHz	(14 – 54)	3
12	EQ Gain	-12 – +12dB	(52 – 76)	
13	EQ Width	1.0 – 12.0	(10 – 120)	
14	—			
15	—			
16	—			

[3] DIGITAL TURNTABLE

No.	Parameter	Range	Value	Table No.
1	Click Density	0 – 5	(0 – 5)	
2	Click Level	0 – 127	(0 – 127)	
3	Noise Tone	0 – 6	(0 – 6)	
4	Noise Mod Speed	0.00Hz – 39.7Hz	(0 – 127)	1
5	Noise Mod Depth	0 – 127	(0 – 127)	
6	Dry Send to Noise	0 – 127	(0 – 127)	
7	Noise LPF Cutoff Frequency	1.0kHz – 20.0kHz	(34 – 60)	3
8	Noise LPF Q	1.0 – 12.0	(10 – 120)	
9	Noise Level	0 – 127	(0 – 127)	
10	—			
11	Dry Level	0 – 127	(0 – 127)	
12	Dry LPF Cutoff Frequency	1.0kHz – 20.0kHz	(34 – 60)	3
13	—			
14	—			
15	—			
16	—			

Category — TEC

[1] RING MODULATOR

No.	Parameter	Range	Value	Table No.
1	OSC Frequency Coarse	0.5 – 5kHz	(0 – 127)	17
2	OSC Frequency Fine	0 – 127	(0 – 127)	
3	LFO Wave	Tri, Sine	(0 – 1)	
4	LFO Depth	0 – 127	(0 – 127)	
5	LFO Speed	0.0Hz – 39.70Hz	(0 – 127)	1
6	HPF Cutoff Frequency	20Hz – 8.0kHz	(0 – 52)	3
7	LPF Cutoff Frequency	1.0kHz – 20.0kHz	(34 – 60)	3
8	—			
9	—			
10	Dry/Wet Balance	D63>W – D=W – D<W63	(1 – 127)	
11	—			
12	—			

13 – 16: Same as the parameters shaded in gray in CROSS DELAY on page 79.

[2] DYNAMIC RING MODULATOR

No.	Parameter	Range	Value	Table No.
1	Sensitivity	0 – 127	(0 – 127)	
2	HPF Cutoff Frequency	20Hz – 8.0kHz	(0 – 52)	3
3	LPF Cutoff Frequency	1.0kHz – 20.0kHz	(34 – 60)	3
4	Attack Time	0.3ms – 227ms	(0 – 127)	15
5	Release Time	2.6ms – 2171ms	(0 – 127)	16
6	Release Curve	0 – 127	(0 – 127)	
7	Direction	Up, Down	(0 – 1)	
8	Dyna Threshold Level	0 – 127	(0 – 127)	
9	Dyna Level Offset	0 – 127	(0 – 127)	
10	Dry/Wet Balance	D63>W – D=W – D<W63	(1 – 127)	
11	—			
12	—			

13 – 16: Same as the parameters shaded in gray in CROSS DELAY on page 79.

[3] DYNAMIC FILTER

No.	Parameter	Range	Value	Table No.
1	Filter Type	LPF (12dB), LPF (18dB), LPF (24dB), HPF, BPF, BEF	(0 – 5)	
2	Sensitivity	0 – 127	(0 – 127)	
3	Dyna Level Offset	0 – 127	(0 – 127)	
4	Resonance	-16 – +111	(0 – 127)	
5	Attack Time	0.3ms – 227ms	(0 – 127)	15
6	Release Time	2.6ms – 2171ms	(0 – 127)	16
7	Release Curve	0 – 127	(0 – 127)	
8	Direction	Up, Down	(0 – 1)	
9	Dyna Threshold Level	0 – 127	(0 – 127)	
10	Dry/Wet Balance	D63>W – D=W – D<W63	(1 – 127)	
11	—			
12	—			

13 – 16: Same as the parameters shaded in gray in CROSS DELAY on page 79.

[4] AUTO SYNTH

No.	Parameter	Range	Value	Table No.
1	Mod Speed	0 – 127	(0 – 127)	
2	Mod Wave Type	Type A, Type B, Type C, Type D	(0 – 3)	
3	Mod Depth	0 – 127	(0 – 127)	
4	Mod Depth Ofst R	-63 – +63	(1 – 127)	
5	HPF Cutoff Frequency	20Hz – 8.0kHz	(0 – 52)	3
6	LPF Cutoff Frequency	1.0kHz – 20.0kHz	(34 – 60)	3
7	Delay Time	0.1 – 370.0ms	(1 – 3700)	
8	Delay Time Ofst R	0 – 884	(0 – 884)	
9	Delay Level	0 – 127	(0 – 127)	
10	Dry Mix Level	0 – 127	(0 – 127)	
11	Feedback Level	-63 – +63	(1 – 127)	
12	FB Level Ofst R	-63 – +63	(1 – 127)	
13	AM Speed	0.00Hz – 39.7Hz	(0 – 127)	1
14	AM Wave	Tri, Sine, Saw Up, Saw Down	(0 – 3)	
15	AM Depth	0 – 127	(0 – 127)	
16	AM Inverse R	Normal, Inverse	(0 – 1)	

[5] ISOLATOR

No.	Parameter	Range	Value	Table No.
1	On/off Switch	On, Off	(0 – 1)	
2	Low Level	-64 – +63	(0 – 127)	
3	Mid Level	-64 – +63	(0 – 127)	
4	High Level	-64 – +63	(0 – 127)	
5	Low Mute	Off/On	(0 – 1)	
6	Mid Mute	Off/On	(0 – 1)	
7	High Mute	Off/On	(0 – 1)	
8	—			
9	—			
10	—			
11	—			
12	—			
13	—			
14	—			
15	—			
16	—			

[6] SLICE

No.	Parameter	Range	Value	Table No.
1	Divide Type	16th – 4th	(5 – 11)	13
2	Gate Time	0 – 100%	(0 – 100)	
3	Pan AEG Type	A – E	(0 – 4)	
4	Pan AEG Min Level	0 – 127	(0 – 127)	
5	Pan Depth	-63 – +63	(1 – 127)	
6	Divide Min Level	0 – 127	(0 – 127)	
7	Pan Type	A – J	(0 – 9)	
8	Drive	0 – 127	(0 – 127)	
9	AEG Phase	0 – 15 (x 16th note)	(0 – 15)	
10	Dry/Wet Balance	D63>W – D=W – D<W63	(1 – 127)	
11	—			
12	—			

13 – 16: Same as the parameters shaded in gray in CROSS DELAY on page 79.

[7] TECH MODULATION

No.	Parameter	Range	Value	Table No.
1	Mod Speed	0 – 127	(0 – 127)	
2	Mod Depth	0 – 127	(0 – 127)	
3	Mod Gain	-12 – +12dB	(52 – 76)	
4	Mod Mix Balance	D63>W – D=W – D<W63	(1 – 127)	
5	Pre Mod HPF Cutoff Frequency	20Hz – 8.0kHz	(0 – 52)	3
6	Mod LPF Cutoff Frequency	1.0kHz – 20.0kHz	(34 – 60)	3
7	Mod LPF Resonance	1.0 – 12.0	(10 – 120)	
8	Delay Time	0.1 – 740.0ms	(1 – 7400)	
9	Delay Time Ofst R	0 – 884	(0 – 884)	
10	Dry/Wet Balance	D63>W – D=W – D<W63	(1 – 127)	
11	Feedback Level	-63 – +63	(1 – 127)	
12	FB Level Ofst R	-63 – +63	(1 – 127)	
13	Feedback Hi Damp	0.1 – 1.0	(1 – 10)	
14	FB Hi Damp Ofst R	-0.9 – +0.9	(1 – 19)	
15	—			
16	—			

Category — MISC

[1] VCM EQ 501

No.	Parameter	Range	Value	Table No.
1	EQ1 (LSH) Frequency	31.5Hz – 2.0kHz	(12 – 84)	28
2	EQ1 (LSH) Gain	-12.0dB – +12.0dB	(60 – 300)	
3	EQ2 Q	0.50 – 16.00	(0 – 60)	29
4	EQ2 Frequency	50.0 Hz – 20.0kHz	(20 – 124)	28
5	EQ2 Gain	-18.0dB – +18.0dB	(0 – 360)	
6	EQ3 Q	0.50 – 16.00	(0 – 60)	29
7	EQ3 Frequency	50.0 Hz – 20.0kHz	(20 – 124)	28
8	EQ3 Gain	-18.0dB – +18.0dB	(0 – 360)	
9	EQ4 Q	0.50 – 16.00	(0 – 60)	29
10	EQ4 Frequency	50.0 Hz – 20.0kHz	(20 – 124)	28
11	EQ4 Gain	-18.0dB – +18.0dB	(0 – 360)	
12	EQ5 (HSH) Frequency	500Hz – 20.0kHz	(60 – 124)	28
13	EQ5 (HSH) Gain	-12.0dB – +12.0dB	(60 – 300)	
14	Output Level	-12.0dB – +12.0dB	(60 – 300)	
15	—			
16	—			

[2] HARMONIC ENHANCER

No.	Parameter	Range	Value	Table No.
1	HPF Cutoff Frequency	500Hz – 16.0kHz	(28 – 58)	3
2	Drive	0 – 127	(0 – 127)	
3	Mix Level	0 – 127	(0 – 127)	
4	—			
5	—			
6	—			
7	—			
8	—			
9	—			
10	—			
11	—			
12	—			
13	—			
14	—			
15	—			
16	—			

[3] Talking Modulator

No.	Parameter	Range	Value	Table No.
1	Vowel	a/i/u/e/o	(0 – 4)	
2	Move Speed	1 – 62	(1 – 62)	
3	Drive	0 – 127	(0 – 127)	
4	Output Level	0 – 127	(0 – 127)	
5	—			
6	—			
7	—			
8	—			
9	—			
10	—			
11	—			
12	—			
13	—			
14	—			
15	—			
16	—			

[4] DAMPER RESONANCE

No.	Parameter	Range	Value	Table No.
1	HPF Cutoff Frequency	20Hz – 8.0kHz	(0 – 52)	3
2	LPF Cutoff Frequency	1.0kHz – 20.0kHz	(34 – 60)	3
3	EQ Low Frequency	32Hz – 2.0kHz	(4 – 40)	3
4	EQ Low Gain	-12 – +12dB	(52 – 76)	
5	Hi Resonance	0.1 – 1.0	(1 – 10)	
6	Pedal Response	Slow/Normal/Fast	(0 – 2)	
7	—			
8	—			
9	—			
10	Dry/Wet Balance	D63>W – D=W – D<W63	(1 – 127)	
11	—			
12	—			
13	—			
14	—			
15	—			
16	Damper Control	0 – 127	(0 – 127)	

[5] PITCH CHANGE

No.	Parameter	Range	Value	Table No.
1	Pitch 1	-24 – +24	(40 – 88)	
2	Fine 1	-50 – +50	(14 – 114)	
3	Initial Delay 1	0.1ms – 400.0ms	(0 – 127)	7
4	Feedback Level 1	-63 – +63	(1 – 127)	
5	Pitch 2	-24 – +24	(40 – 88)	
6	Fine 2	-50 – +50	(14 – 114)	
7	Initial Delay 2	0.1ms – 400.0ms	(0 – 127)	7
8	Feedback Level 2	-63 – +63	(1 – 127)	
9	—			
10	Dry/Wet Balance	D63>W – D=W – D<W63	(1 – 127)	
11	Pan 1	L63 – C – R63	(1 – 127)	
12	Output Level 1	0 – 127	(0 – 127)	
13	Pan 2	L63 – C – R63	(1 – 127)	
14	Output Level 2	0 – 127	(0 – 127)	
15	—			
16	—			

[6] EARLY REFLECTION

No.	Parameter	Range	Value	Table No.
1	Type	S-hall, L-hall, Random, Reverse, Plate, Spring	(0 – 5)	
2	Room Size	0.1 – 20.0	(0 – 127)	6
3	Diffusion	0 – 10	(0 – 10)	
4	Initial Delay	0.1ms – 200.0ms	(0 – 127)	5
5	Feedback Level	-63 – +63	(1 – 127)	
6	HPF Cutoff Frequency	20Hz – 8.0kHz	(0 – 52)	3
7	LPF Cutoff Frequency	1.0kHz – 20.0kHz	(34 – 60)	3
8	—			
9	—			
10	Dry/Wet Balance	D63>W – D=W – D<W63	(1 – 127)	
11	Liveness	0 – 10	(0 – 10)	
12	Density	0 – 3	(0 – 3)	
13	Feedback High Damp	0.1 – 1.0	(1 – 10)	
14	—			
15	—			
16	—			

[7] NOISE GATE + COMP + EQ

No.	Parameter	Range	Value	Table No.
1	Comp Attack	1ms – 40ms	(0 – 19)	8
2	Comp Release	10ms – 680ms	(0 – 15)	9
3	Comp Threshold	-48dB – -6dB	(79 – 121)	
4	Comp Ratio	1.0 – 20.0	(0 – 7)	10
5	Comp Output Level	0 – 127	(0 – 127)	
6 – 9: Same as the parameters shaded in gray in CROSS DELAY on page 79.				
10	—			
11	Noise Gate Attack	1ms – 40ms	(0 – 19)	
12	Noise Gate Release	10ms – 680ms	(0 – 15)	
13	Noise Gate Threshold	-73dB – -30dB	(54 – 97)	
14	EQ Mid Frequency	100Hz – 10.0kHz	(14 – 54)	3
15	EQ Mid Gain	-12dB – +12dB	(52 – 76)	
16	EQ Mid Width	0.1 – 12.0	(1 – 120)	

Insertion L Block**[0] THRU**

When this type is selected, no parameters are available.

[1] VOCODER

No.	Parameter	Range	Value	Table No.
1	Formant Shift	-2, -1, 0, +1, +2	(62 – 66)	
2	Formant Offset	-63 – +63	(1 – 127)	
3	Vocoder Attack	1ms – 200ms	(0 – 29)	8
4	Vocoder Release	10ms – 3000ms	(0 – 23)	9
5	Gate Switch	Off/On	(0 – 1)	
6	Mic Gate Threshold	-72dB – -30dB	(55 – 97)	
7	HPF Cutoff Frequency	Thru, 500Hz – 16.0kHz	(27 – 58)	3
8	HPF Output Level	0 – 127	(0 – 127)	
9	—			
10	Dry/Wet Balance	D63>W – D=W – D<W63	(1 – 127)	
11	Mic Level	0 – 127	(0 – 127)	
12	Inst Input Level	0 – 127	(0 – 127)	
13	Noise Input Level	0 – 127	(0 – 127)	
14	Output Level	0 – 127	(0 – 127)	
15	BPF1 Gain	-18dB – +18dB	(46 – 82)	
16	BPF2 Gain	-18dB – +18dB	(46 – 82)	
17	BPF3 Gain	-18dB – +18dB	(46 – 82)	
18	BPF4 Gain	-18dB – +18dB	(46 – 82)	
19	BPF5 Gain	-18dB – +18dB	(46 – 82)	
20	BPF6 Gain	-18dB – +18dB	(46 – 82)	
21	BPF7 Gain	-18dB – +18dB	(46 – 82)	
22	BPF8 Gain	-18dB – +18dB	(46 – 82)	
23	BPF9 Gain	-18dB – +18dB	(46 – 82)	
24	BPF10 Gain	-18dB – +18dB	(46 – 82)	

Master Effect Block

THRU type is not included in the Master Effect Block. If you wish to bypass this block, turn the EFFECT [MASTER] button off.

DELAY L, R (Stereo)**LO-FI****COMP DISTORTION****ISOLATOR****DYNAMIC FILTER****SLICE****RING MODULATOR****MULTI BAND COMP****VCM COMPRESSOR 376****Master EQ Block****[0] MEQ**

No.	Parameter	Range	Value	Table No.
1	EQ1 Gain	-12dB – +12dB	(52 – 76)	
2	EQ1 Frequency	32Hz – 2.0kHz	(4 – 40)	3
3	EQ1 Q	0.1 – 12.0	(1 – 120)	
4	EQ1 Shape	Shelving, Peaking	(0 – 1)	
5	EQ2 Gain	-12dB – +12dB	(52 – 76)	
6	EQ2 Frequency	100Hz – 10kHz	(14 – 54)	3
7	EQ2 Q	0.1 – 12.0	(1 – 120)	
8	—			
9	EQ3 Gain	-12dB – +12dB	(52 – 76)	
10	EQ3 Frequency	100Hz – 10kHz	(14 – 54)	3
11	EQ3 Q	0.1 – 12.0	(1 – 120)	
12	—			
13	EQ4 Gain	-12dB – +12dB	(52 – 76)	
14	EQ4 Frequency	100Hz – 10kHz	(14 – 54)	3
15	EQ4 Q	0.1 – 12.0	(1 – 120)	
16	—			
17	EQ5 Gain	-12dB – +12dB	(52 – 76)	
18	EQ5 Frequency	500Hz – 16kHz	(28 – 58)	3
19	EQ5 Q	0.1 – 12.0	(1 – 120)	
20	EQ5 Shape	Shelving, Peaking	(0 – 1)	

When the EQ Shape1 is set to Peaking, the range of EQ Frequency 1 is 63Hz – 2.0kHz (10 – 40).

Effect Preset List

Category	Effect Type Name	Preset Name
Reverb	Rev-X Hall	Basic Small Hall Clean Church Bright Hall
	R3 Hall	Basic Big Hall Backstage Ballad Light
	SPX Hall	Basic Big Hall Backstage Light Gymnasium
	Rev-X Room	Basic Basement Garage Bedroom
	R3 Room	Basic Open Wide Tight
	SPX Room	Basic Open Wide Tight
	R3 Plate	Basic Bright Vocal Smooth Vocal Short Bright Metal Splash
	SPX Stage	Basic Small Big
	Space Simulator	Tunnel Basement Canyon White Room Small Room Live Room 3 Walls
	Delay	Control Delay
Cross Delay		Basic Short Long Very Long
Tempo Cross Delay		4beat Echo Dotted 8th Echo 8beat Echo Triplet Echo 2beat Echo
Tempo Delay Mono		4beat Echo Mono Out 4beat Dotted 8th Echo 8beat Echo Mono Out Dot8 Mono Out 8beat Triplet Echo Triplet Mono Analog Delay
Tempo Delay Stereo		4beat Echo Dotted 8th Echo 8beat Echo Triplet Echo
Delay LR		Basic Mono Doubling Short Fast Long Very Long Analog Delay Ping Pong Bounce
Delay LCR		Bounce Analog Delay
Delay LR Stereo		Basic Doubling Short
Delay LR Stereo		Fast Long Very Long Analog Delay

Category	Effect Type Name	Preset Name
Chorus	G Chorus	Basic Fast Deep Mist Bright
	2 Modulator	Basic Fast Deep Mist Multi Panning Mod Vibrator Wonder Shimmer
	SPX Chorus	Basic Fast Deep Slow Flangy
	Symphonic	Basic Fast Deep Slow Analog
	Ensemble Detune	Basic Soft Wide Deep Wide Stereo Sim
	Flanger	VCM Flanger
Classic Flanger		Basic Flange Chorus Psychedelic Jet
Tempo Flanger		Deep Mod Flange Chorus Metallic Psychedelic Jet
Dynamic Flanger		Follow Reverse Distorted Sync
Phaser	VCM Phaser Mono	E.Piano Orange90 Two Phase Deep Six Deep Eight Lite Eight Deep Sweeper Orange100 Red Twelve Blue Sixteen Clavi1 Clavi2 E.Guitar1 E.Guitar2 E.Guitar3 Vibrato1 Vibrato2 Vibrato3 Ambience1 Ambience2
	VCM Phaser Stereo	Deep Sweeper E.Piano1 E.Piano2 Clavi1 Clavi2 E.Guitar1 E.Guitar2 E.Guitar3 Deep Six Deep Eight Vibrato1
	VCM Phaser Stereo	Vibrato2 Vibrato3 Ambience1 Ambience2
	Tempo Phaser	Basic Deep Phase
	Dynamic Phaser	Follow Reverse Light

Category	Effect Type Name	Preset Name
Tremolo&Rotary	Auto Pan	E.Piano Smooth Oval Right Turn Super Slow
	Tremolo	Fast Slow Super Fast Stereo Vibrato Spring Relax
	Rotary Speaker	Basic Horn Mic Light Heavy Rotor Fast First
Distortion	Amp Simulator 1	Stack1 Stack2 Twin Boost Old Amp Transistor Modern US-Clean J-Clean Fuzz Small Blues Buzzy Bottom Beat Crunch Beat Drive
	Amp Simulator 2	Stack1 Stack2 Combo Crunch Hi Gain British Tube Drive Tube Clean
	Comp Distortion	Basic Booster School Boy Detroit Long Lead 80s Clean
	Comp Distortion Delay	Hard1 Hard2 Grunge Voodoo Texas Rockabilly LA Session Thin Techno
Compressor	VCM Compressor 376	Basic Comp Sustainer 60s DrumKit Natural Kick Old Piano Valve Tone Bass Hard Basic Fast Atk + Boost Soft Atk + Boost Attack & Tight Hard Atk + Boost Vocal Comp 117x Unplugged Attack Comp Punchy Master Pinched
	Classic Compressor	Basic Attack For Vintage Keys Pack Comp Gate Tight Pop Rhythm Cutting Comp Basic Bass Old Record Piano
	Multi Band Comp	Basic Maximizer Wild Attacky Hard Hip Club Slap Bass(ch)

Category	Effect Type Name	Preset Name
Wah	VCM Auto Wah	Low High For Bass
	VCM Touch Wah	Follow Hi Q For Bass Reverse
	VCM Pedal Wah	Low High
Lo-Fi	Lo-Fi	Lo-Fi Old Phone Overload Max Lo-Fi
	Noisy	Noisy Tremolo Noise Fuzz Noise
	Digital Turntable	Old Record1 Old Record2 Short Wave Radio
Tech	Ring Modulator	Basic Slow Tremolo Crazy
	Dynamic Ring Modulator	Basic Metallic Sputter Sharp Edge
	Dynamic Filter	Basic HiPass LoPass Squish
	Auto Synth	Echo Space Walking Robot Delay
	Isolator	Mid Only Near Flat
	Slice	Slice Beat 8th Pan 16th Mute Rock
MISC	Tec Modulation	Star Train Numerator Active Dist Astonish Drift Armor
	VCM EQ 501	Flat Radio Speaker Dance Bd & Sn
	Harmonic Enhancer	Edge Hi Edge Mid Edge
	Talking Modulator	Basic
	Damper Resonance	Basic
	Pitch Change	Detune Oct Echo Octaver Plus 4th Minus 4th Oval Step Up Step Down
	Early Reflections	Close Far Reverse Gate 70s Gate
	NOISE GATE+COMP+EQ	Basic

Effect Data Assign Table

Table #1
LFO Frequency

Data	Value	Data	Value
0	0.00	64	2.69
1	0.04	65	2.78
2	0.08	66	2.86
3	0.13	67	2.94
4	0.17	68	3.03
5	0.21	69	3.11
6	0.25	70	3.20
7	0.29	71	3.28
8	0.34	72	3.37
9	0.38	73	3.45
10	0.42	74	3.53
11	0.46	75	3.62
12	0.51	76	3.70
13	0.55	77	3.87
14	0.59	78	4.04
15	0.63	79	4.21
16	0.67	80	4.37
17	0.72	81	4.54
18	0.76	82	4.71
19	0.80	83	4.88
20	0.84	84	5.05
21	0.88	85	5.22
22	0.93	86	5.38
23	0.97	87	5.55
24	1.01	88	5.72
25	1.05	89	6.06
26	1.09	90	6.39
27	1.14	91	6.73
28	1.18	92	7.07
29	1.22	93	7.40
30	1.26	94	7.74
31	1.30	95	8.08
32	1.35	96	8.41
33	1.39	97	8.75
34	1.43	98	9.08
35	1.47	99	9.42
36	1.51	100	9.76
37	1.56	101	10.1
38	1.60	102	10.8
39	1.64	103	11.4
40	1.68	104	12.1
41	1.72	105	12.8
42	1.77	106	13.5
43	1.81	107	14.1
44	1.85	108	14.8
45	1.89	109	15.5
46	1.94	110	16.2
47	1.98	111	16.8
48	2.02	112	17.5
49	2.06	113	18.2
50	2.10	114	19.5
51	2.15	115	20.9
52	2.19	116	22.2
53	2.23	117	23.6
54	2.27	118	24.9
55	2.31	119	26.2
56	2.36	120	27.6
57	2.40	121	28.9
58	2.44	122	30.3
59	2.48	123	31.6
60	2.52	124	33.0
61	2.57	125	34.3
62	2.61	126	37.0
63	2.65	127	39.7

Table #2
Modulation Delay Offset

Data	Value	Data	Value
0	0.0	64	6.4
1	0.1	65	6.5
2	0.2	66	6.6
3	0.3	67	6.7
4	0.4	68	6.8
5	0.5	69	6.9
6	0.6	70	7.0
7	0.7	71	7.1
8	0.8	72	7.2
9	0.9	73	7.3
10	1.0	74	7.4
11	1.1	75	7.5
12	1.2	76	7.6
13	1.3	77	7.7
14	1.4	78	7.8
15	1.5	79	7.9
16	1.6	80	8.0
17	1.7	81	8.1
18	1.8	82	8.2
19	1.9	83	8.3
20	2.0	84	8.4
21	2.1	85	8.5
22	2.2	86	8.6
23	2.3	87	8.7
24	2.4	88	8.8
25	2.5	89	8.9
26	2.6	90	9.0
27	2.7	91	9.1
28	2.8	92	9.2
29	2.9	93	9.3
30	3.0	94	9.4
31	3.1	95	9.5
32	3.2	96	9.6
33	3.3	97	9.7
34	3.4	98	9.8
35	3.5	99	9.9
36	3.6	100	10.0
37	3.7	101	11.1
38	3.8	102	12.2
39	3.9	103	13.3
40	4.0	104	14.4
41	4.1	105	15.5
42	4.2	106	17.1
43	4.3	107	18.6
44	4.4	108	20.2
45	4.5	109	21.8
46	4.6	110	23.3
47	4.7	111	24.9
48	4.8	112	26.5
49	4.9	113	28.0
50	5.0	114	29.6
51	5.1	115	31.2
52	5.2	116	32.8
53	5.3	117	34.3
54	5.4	118	35.9
55	5.5	119	37.5
56	5.6	120	39.0
57	5.7	121	40.6
58	5.8	122	42.2
59	5.9	123	43.7
60	6.0	124	45.3
61	6.1	125	46.9
62	6.2	126	48.4
63	6.3	127	50.0

Table #3
EQ Frequency

Data	Value
0	THRU (20)
1	22
2	25
3	28
4	32
5	36
6	40
7	45
8	50
9	56
10	63
11	70
12	80
13	90
14	100
15	110
16	125
17	140
18	160
19	180
20	200
21	225
22	250
23	280
24	315
25	355
26	400
27	450
28	500
29	560
30	630
31	700
32	800
33	900
34	1.0k
35	1.1k
36	1.2k
37	1.4k
38	1.6k
39	1.8k
40	2.0k
41	2.2k
42	2.5k
43	2.8k
44	3.2k
45	3.6k
46	4.0k
47	4.5k
48	5.0k
49	5.6k
50	6.3k
51	7.0k
52	8.0k
53	9.0k
54	10.0k
55	11.0k
56	12.0k
57	14.0k
58	16.0k
59	18.0k
60	THRU(20.0k)

Table #4
Reverb time

Data	Value	Data	Value
0	0.3	64	17.0
1	0.4	65	18.0
2	0.5	66	19.0
3	0.6	67	20.0
4	0.7	68	25.0
5	0.8	69	30.0
6	0.9		
7	1.0		
8	1.1		
9	1.2		
10	1.3		
11	1.4		
12	1.5		
13	1.6		
14	1.7		
15	1.8		
16	1.9		
17	2.0		
18	2.1		
19	2.2		
20	2.3		
21	2.4		
22	2.5		
23	2.6		
24	2.7		
25	2.8		
26	2.9		
27	3.0		
28	3.1		
29	3.2		
30	3.3		
31	3.4		
32	3.5		
33	3.6		
34	3.7		
35	3.8		
36	3.9		
37	4.0		
38	4.1		
39	4.2		
40	4.3		
41	4.4		
42	4.5		
43	4.6		
44	4.7		
45	4.8		
46	4.9		
47	5.0		
48	5.5		
49	6.0		
50	6.5		
51	7.0		
52	7.5		
53	8.0		
54	8.5		
55	9.0		
56	9.5		
57	10.0		
58	11.0		
59	12.0		
60	13.0		
61	14.0		
62	15.0		
63	16.0		

Table #5
Delay Time (0.1 – 200.0 [ms])

Data	Value	Data	Value
0	0.1	64	100.8
1	1.7	65	102.4
2	3.2	66	104.0
3	4.8	67	105.6
4	6.4	68	107.1
5	8.0	69	108.7
6	9.5	70	110.3
7	11.1	71	111.9
8	12.7	72	113.4
9	14.3	73	115.0
10	15.8	74	116.6
11	17.4	75	118.2
12	19.0	76	119.7
13	20.6	77	121.3
14	22.1	78	122.9
15	23.7	79	124.4
16	25.3	80	126.0
17	26.9	81	127.6
18	28.4	82	129.2
19	30.0	83	130.7
20	31.6	84	132.3
21	33.2	85	133.9
22	34.7	86	135.5
23	36.3	87	137.0
24	37.9	88	138.6
25	39.5	89	140.2
26	41.0	90	141.8
27	42.6	91	143.3
28	44.2	92	144.9
29	45.7	93	146.5
30	47.3	94	148.1
31	48.9	95	149.6
32	50.5	96	151.2
33	52.0	97	152.8
34	53.6	98	154.4
35	55.2	99	155.9
36	56.8	100	157.5
37	58.3	101	159.1
38	59.9	102	160.6
39	61.5	103	162.2
40	63.1	104	163.8
41	64.6	105	165.4
42	66.2	106	166.9
43	67.8	107	168.5
44	69.4	108	170.1
45	70.9	109	171.7
46	72.5	110	173.2
47	74.1	111	174.8
48	75.7	112	176.4
49	77.2	113	178.0
50	78.8	114	179.5
51	80.4	115	181.1
52	81.9	116	182.7
53	83.5	117	184.3
54	85.1	118	185.8
55	86.7	119	187.4
56	88.2	120	189.0
57	89.8	121	190.6
58	91.4	122	192.1
59	93.0	123	193.7
60	94.5	124	195.3
61	96.1	125	196.9
62	97.7	126	198.4
63	99.3	127	200.0

Table #6
Room Size

Data	Value	Data	Value
0	0.1	64	10.1
1	0.3	65	10.3
2	0.4	66	10.4
3	0.6	67	10.6
4	0.7	68	10.8
5	0.9	69	10.9
6	1.0	70	11.1
7	1.2	71	11.2
8	1.4	72	11.4
9	1.5	73	11.5
10	1.7	74	11.7
11	1.8	75	11.9
12	2.0	76	12.0
13	2.1	77	12.2
14	2.3	78	12.3
15	2.5	79	12.5
16	2.6	80	12.6
17	2.8	81	12.8
18	2.9	82	12.9
19	3.1	83	13.1
20	3.2	84	13.3
21	3.4	85	13.4
22	3.5	86	13.6
23	3.7	87	13.7
24	3.9	88	13.9
25	4.0	89	14.0
26	4.2	90	14.2
27	4.3	91	14.4
28	4.5	92	14.5
29	4.6	93	14.7
30	4.8	94	14.8
31	5.0	95	15.0
32	5.1	96	15.1
33	5.3	97	15.3
34	5.4	98	15.5
35	5.6	99	15.6
36	5.7	100	15.8
37	5.9	101	15.9
38	6.1	102	16.1
39	6.2	103	16.2
40	6.4	104	16.4
41	6.5	105	16.6
42	6.7	106	16.7
43	6.8	107	16.9
44	7.0	108	17.0
45	7.2	109	17.2
46	7.3	110	17.3
47	7.5	111	17.5
48	7.6	112	17.6
49	7.8	113	17.8
50	7.9	114	18.0
51	8.1	115	18.1
52	8.2	116	18.3
53	8.4	117	18.4
54	8.6	118	18.6
55	8.7	119	18.7
56	8.9	120	18.9
57	9.0	121	19.1
58	9.2	122	19.2
59	9.3	123	19.4
60	9.5	124	19.5
61	9.7	125	19.7
62	9.8	126	19.8
63	10.0	127	20.0

Table #7
Delay Time (0.1 – 400.0 [ms])

Data	Value	Data	Value
0	0.1	64	201.6
1	3.2	65	204.8
2	6.4	66	207.9
3	9.5	67	211.1
4	12.7	68	214.2
5	15.8	69	217.4
6	19.0	70	220.5
7	22.1	71	223.7
8	25.3	72	226.8
9	28.4	73	230.0
10	31.6	74	233.1
11	34.7	75	236.3
12	37.9	76	239.4
13	41.0	77	242.6
14	44.2	78	245.7
15	47.3	79	248.9
16	50.5	80	252.0
17	53.6	81	255.2
18	56.8	82	258.3
19	59.9	83	261.5
20	63.1	84	264.6
21	66.2	85	267.7
22	69.4	86	270.9
23	72.5	87	274.0
24	75.7	88	277.2
25	78.8	89	280.3
26	82.0	90	283.5
27	85.1	91	286.6
28	88.3	92	289.8
29	91.4	93	292.9
30	94.6	94	296.1
31	97.7	95	299.2
32	100.9	96	302.4
33	104.0	97	305.5
34	107.2	98	308.7
35	110.3	99	311.8
36	113.5	100	315.0
37	116.6	101	318.1
38	119.8	102	321.3
39	122.9	103	324.4
40	126.1	104	327.6
41	129.2	105	330.7
42	132.4	106	333.9
43	135.5	107	337.0
44	138.6	108	340.2
45	141.8	109	343.3
46	144.9	110	346.5
47	148.1	111	349.6
48	151.2	112	352.8
49	154.4	113	355.9
50	157.5	114	359.1
51	160.7	115	362.2
52	163.8	116	365.4
53	167.0	117	368.5
54	170.1	118	371.7
55	173.3	119	374.8
56	176.4	120	378.0
57	179.6	121	381.1
58	182.7	122	384.3
59	185.9	123	387.4
60	189.0	124	390.6
61	192.2	125	393.7
62	195.3	126	396.9
63	198.5	127	400.0

Table #8
Compressor/Vocoder Attack Time

Data	Value
0	1
1	2
2	3
3	4
4	5
5	6
6	7
7	8
8	9
9	10
10	12
11	14
12	16
13	18
14	20
15	23
16	26
17	30
18	35
19	40
20	50
21	60
22	70
23	80
24	100
25	120
26	140
27	160
28	180
29	200

Table #9
Compressor/Vocoder Release Time

Data	Value
0	10
1	15
2	25
3	35
4	45
5	55
6	65
7	75
8	85
9	100
10	115
11	140
12	170
13	230
14	340
15	680
16	850
17	1000
18	1200
19	1500
20	1700
21	2000
22	2400
23	3000

Table #10
Compressor Ratio

Data	Value
0	1.0
1	1.5
2	2.0
3	3.0
4	5.0
5	7.0
6	10.0
7	20.0

Table #11
Reverb Width; Depth; Height

Data	Value	Data	Value
0	0.5	64	17.6
1	0.8	65	17.9
2	1.0	66	18.2
3	1.3	67	18.5
4	1.5	68	18.8
5	1.8	69	19.1
6	2.0	70	19.4
7	2.3	71	19.7
8	2.6	72	20.0
9	2.8	73	20.2
10	3.1	74	20.5
11	3.3	75	20.8
12	3.6	76	21.1
13	3.9	77	21.4
14	4.1	78	21.7
15	4.4	79	22.0
16	4.6	80	22.4
17	4.9	81	22.7
18	5.2	82	23.0
19	5.4	83	23.3
20	5.7	84	23.6
21	5.9	85	23.9
22	6.2	86	24.2
23	6.5	87	24.5
24	6.7	88	24.9
25	7.0	89	25.2
26	7.2	90	25.5
27	7.5	91	25.8
28	7.8	92	26.1
29	8.0	93	26.5
30	8.3	94	26.8
31	8.6	95	27.1
32	8.8	96	27.5
33	9.1	97	27.8
34	9.4	98	28.1
35	9.6	99	28.5
36	9.9	100	28.8
37	10.2	101	29.2
38	10.4	102	29.5
39	10.7	103	29.9
40	11.0	104	30.2
41	11.2		
42	11.5		
43	11.8		
44	12.1		
45	12.3		
46	12.6		
47	12.9		
48	13.1		
49	13.4		
50	13.7		
51	14.0		
52	14.2		
53	14.5		
54	14.8		
55	15.1		
56	15.4		
57	15.6		
58	15.9		
59	16.2		
60	16.5		
61	16.8		
62	17.1		
63	17.3		

Table #12
LO-FI Sampling Frequency Control

Data	Value	Data	Value
0	44.1k	64	678.5
1	22.1k	65	668.2
2	14.7k	66	658.2
3	11.0k	67	648.5
4	8.82k	68	639.1
5	7.35k	69	630.0
6	6.30k	70	621.1
7	5.51k	71	612.5
8	4.90k	72	604.1
9	4.41k	73	595.9
10	4.01k	74	588.0
11	3.68k	75	580.3
12	3.39k	76	572.7
13	3.15k	77	565.4
14	2.94k	78	558.2
15	2.76k	79	551.3
16	2.59k	80	544.4
17	2.45k	81	537.8
18	2.32k	82	531.3
19	2.21k	83	525.0
20	2.10k	84	518.8
21	2.00k	85	512.8
22	1.92k	86	506.9
23	1.84k	87	501.1
24	1.76k	88	495.5
25	1.70k	89	490.0
26	1.63k	90	484.6
27	1.58k	91	479.3
28	1.52k	92	474.2
29	1.47k	93	469.1
30	1.42k	94	464.2
31	1.38k	95	459.4
32	1.34k	96	454.6
33	1.30k	97	450.0
34	1.26k	98	445.5
35	1.23k	99	441.0
36	1.19k	100	436.6
37	1.16k	101	432.4
38	1.13k	102	428.2
39	1.10k	103	424.0
40	1.08k	104	420.0
41	1.05k	105	416.0
42	1.03k	106	412.1
43	1.00k	107	408.3
44	980.0	108	404.6
45	958.7	109	400.9
46	938.3	110	397.3
47	918.8	111	393.8
48	900.0	112	390.3
49	882.0	113	386.8
50	864.7	114	383.5
51	848.1	115	380.2
52	832.1	116	376.9
53	816.7	117	373.7
54	801.8	118	370.6
55	787.5	119	367.5
56	773.7	120	364.5
57	760.3	121	361.5
58	747.5	122	358.5
59	735.0	123	355.6
60	723.0	124	352.8
61	711.3	125	350.0
62	700.0	126	347.2
63	689.1	127	344.5

Table #13
Tempo

Data	Value
0	32nd/3
1	64th.
2	32nd
3	16th/3
4	32nd.
5	16th
6	8th/3
7	16th.
8	8th
9	4th/3
10	8th.
11	4th
12	2nd/3
13	4th.
14	2nd
15	Whole/3
16	2nd.
17	4thX4
18	4thX5
19	4thX6
20	4thX7
21	4thX8
22	4thX9
23	4thX10
24	4thX11
25	4thX12
26	4thX13
27	4thX14
28	4thX15
29	4thX16

Table #14
Multi Compressor
Gain (dB)

Data	Value
0	-∞
1	-60
2	-57
3	-54
4	-51
5	-48
6	-45
7	-42
8	-39
9	-36
10	-33
11	-30
12	-27
13	-24
14	-23
15	-22
16	-21
17	-20
18	-19
19	-18
20	-17
21	-16
22	-15
23	-14
24	-13
25	-12
26	-11
27	-10
28	-9
29	-8
30	-7
31	-6
32	-5
33	-4
34	-3
35	-2
36	-1
37	0
38	1
39	2
40	3
41	4
42	5
43	6
44	7
45	8
46	9
47	10
48	11
49	12
50	13
51	14
52	15
53	16
54	17
55	18

Table #15
Dyna Attack Time (ms)

Data	Value	Data	Value
0	0.3	64	112
1	0.9	65	114
2	1.8	66	116
3	2.7	67	118
4	3.6	68	120
5	5.4	69	121
6	7.2	70	123
7	9.0	71	125
8	10	72	127
9	12	73	129
10	14	74	130
11	16	75	132
12	18	76	134
13	20	77	136
14	21	78	138
15	23	79	140
16	25	80	141
17	27	81	143
18	29	82	145
19	30	83	147
20	32	84	149
21	34	85	150
22	36	86	152
23	38	87	154
24	40	88	156
25	41	89	158
26	43	90	160
27	45	91	161
28	47	92	163
29	49	93	165
30	50	94	167
31	52	95	169
32	54	96	170
33	56	97	172
34	58	98	174
35	60	99	176
36	61	100	178
37	63	101	180
38	65	102	181
39	67	103	183
40	69	104	185
41	70	105	187
42	72	106	189
43	74	107	190
44	76	108	192
45	78	109	194
46	80	110	196
47	81	111	198
48	83	112	200
49	85	113	201
50	87	114	203
51	89	115	205
52	90	116	207
53	92	117	209
54	94	118	210
55	96	119	212
56	98	120	214
57	100	121	216
58	101	122	218
59	103	123	220
60	105	124	221
61	107	125	223
62	109	126	225
63	110	127	227

Table #16
Dyna Release Time (ms)

Data	Value	Data	Value
0	2.6	64	369
1	3.0	65	391
2	3.4	66	413
3	3.9	67	434
4	4.3	68	456
5	4.7	69	478
6	5.2	70	499
7	5.6	71	521
8	6.0	72	543
9	6.5	73	565
10	6.9	74	586
11	7.3	75	608
12	7.8	76	630
13	8.2	77	651
14	8.6	78	673
15	13	79	695
16	17	80	717
17	22	81	738
18	26	82	760
19	30	83	782
20	35	84	803
21	39	85	825
22	43	86	847
23	48	87	869
24	52	88	890
25	56	89	912
26	61	90	934
27	65	91	955
28	69	92	977
29	74	93	999
30	78	94	1021
31	83	95	1042
32	87	96	1064
33	91	97	1086
34	96	98	1107
35	100	99	1129
36	104	100	1151
37	109	101	1173
38	113	102	1194
39	117	103	1216
40	122	104	1238
41	126	105	1259
42	130	106	1281
43	135	107	1303
44	139	108	1346
45	143	109	1390
46	148	110	1433
47	152	111	1477
48	156	112	1520
49	161	113	1563
50	165	114	1607
51	169	115	1650
52	174	116	1694
53	178	117	1737
54	182	118	1781
55	187	119	1824
56	195	120	1867
57	217	121	1911
58	239	122	1954
59	261	123	1998
60	282	124	2041
61	304	125	2085
62	326	126	2128
63	347	127	2171

Table #17
Ring Mod OSC Freq Coarse (Hz)

Data	Value	Data	Value
0	0.5	64	151
1	1.5	65	160
2	2.0	66	169
3	2.5	67	179
4	3.5	68	189
5	4.0	69	200
6	4.5	70	211
7	5.5	71	223
8	6.0	72	236
9	6.5	73	249
10	7.5	74	264
11	8.0	75	279
12	8.4	76	295
13	8.9	77	311
14	9.4	78	329
15	9.9	79	348
16	10.5	80	368
17	11.1	81	389
18	11.7	82	411
19	12.4	83	435
20	13.1	84	459
21	13.9	85	486
22	14.7	86	513
23	15.5	87	543
24	16.4	88	574
25	17.3	89	607
26	18.3	90	641
27	19.4	91	678
28	20.5	92	717
29	21.7	93	757
30	22.9	94	801
31	24.2	95	846
32	25.6	96	895
33	27.1	97	946
34	28.6	98	1.00k
35	30.3	99	1.05k
36	32.0	100	1.11k
37	33.8	101	1.18k
38	35.8	102	1.24k
39	37.8	103	1.32k
40	40.0	104	1.39k
41	42.2	105	1.47k
42	44.7	106	1.55k
43	47.2	107	1.64k
44	49.9	108	1.74k
45	52.7	109	1.84k
46	55.8	110	1.94k
47	58.9	111	2.05k
48	62.3	112	2.17k
49	65.9	113	2.29k
50	69.6	114	2.43k
51	73.6	115	2.56k
52	77.8	116	2.71k
53	82.3	117	2.87k
54	87.0	118	3.03k
55	91.9	119	3.20k
56	97.2	120	3.39k
57	102	121	3.58k
58	108	122	3.79k
59	114	123	4.00k
60	121	124	4.23k
61	128	125	4.47k
62	135	126	4.73k
63	143	127	5.00k

Table #18
V-Flanger Delay Offset

Data	Value	Data	Value	Data	Value
0	0.09	64	4.72	128	31.38
1	0.11	65	4.96	129	31.82
2	0.13	66	5.21	130	32.25
3	0.15	67	5.47	131	32.69
4	0.18	68	5.75	132	33.13
5	0.20	69	6.04	133	33.57
6	0.22	70	6.35	134	34.01
7	0.24	71	6.67	135	34.45
8	0.27	72	7.01	136	34.89
9	0.29	73	7.37	137	35.33
10	0.31	74	7.74	138	35.77
11	0.34	75	8.13	139	36.21
12	0.36	76	8.54		
13	0.38	77	8.97		
14	0.40	78	9.41		
15	0.42	79	9.85		
16	0.43	80	10.29		
17	0.46	81	10.73		
18	0.48	82	11.17		
19	0.51	83	11.61		
20	0.53	84	12.05		
21	0.56	85	12.49		
22	0.59	86	12.93		
23	0.62	87	13.37		
24	0.65	88	13.81		
25	0.68	89	14.24		
26	0.72	90	14.68		
27	0.76	91	15.12		
28	0.79	92	15.56		
29	0.83	93	16.00		
30	0.88	94	16.44		
31	0.92	95	16.88		
32	0.97	96	17.32		
33	1.02	97	17.76		
34	1.07	98	18.20		
35	1.12	99	18.64		
36	1.18	100	19.08		
37	1.24	101	19.52		
38	1.30	102	19.96		
39	1.37	103	20.40		
40	1.44	104	20.83		
41	1.51	105	21.27		
42	1.59	106	21.71		
43	1.67	107	22.15		
44	1.76	108	22.59		
45	1.84	109	23.03		
46	1.94	110	23.47		
47	2.04	111	23.91		
48	2.14	112	24.35		
49	2.25	113	24.79		
50	2.36	114	25.23		
51	2.48	115	25.66		
52	2.61	116	26.10		
53	2.74	117	26.54		
54	2.88	118	26.98		
55	3.03	119	27.42		
56	3.18	120	27.86		
57	3.34	121	28.30		
58	3.51	122	28.74		
59	3.69	123	29.18		
60	3.87	124	29.62		
61	4.07	125	30.06		
62	4.28	126	30.50		
63	4.49	127	30.94		

Table #19
Modulation Phase

Data	Value
0	-180
1	-158
2	-135
3	-113
4	-90
5	-68
6	-45
7	-23
8	0
9	23
10	45
11	68
12	90
13	113
14	135
15	158
16	180

Table #20
VCM Flanger Speed

Data	Value	Data	Value	Data	Value	Data	Value
0	0.040	64	0.247	128	0.988	192	3.953
1	0.042	65	0.252	129	1.009	193	4.037
2	0.045	66	0.258	130	1.030	194	4.122
3	0.047	67	0.263	131	1.051	195	4.206
4	0.050	68	0.268	132	1.072	196	4.290
5	0.053	69	0.273	133	1.093	197	4.374
6	0.055	70	0.281	134	1.125	198	4.500
7	0.058	71	0.287	135	1.146	199	4.584
8	0.060	72	0.292	136	1.167	200	4.668
9	0.063	73	0.300	137	1.199	201	4.752
10	0.066	74	0.308	138	1.220	202	4.879
11	0.068	75	0.313	139	1.251	203	5.005
12	0.071	76	0.321	140	1.272	204	5.131
13	0.074	77	0.326	141	1.304	205	5.215
14	0.076	78	0.334	142	1.335	206	5.341
15	0.079	79	0.342	143	1.367	207	5.467
16	0.081	80	0.347	144	1.409	208	5.552
17	0.084	81	0.357	145	1.430	209	5.720
18	0.087	82	0.363	146	1.451	210	5.804
19	0.089	83	0.373	147	1.493	211	5.972
20	0.092	84	0.379	148	1.514	212	6.056
21	0.095	85	0.389	149	1.556	213	6.224
22	0.097	86	0.400	150	1.577	214	6.309
23	0.100	87	0.405	151	1.619	215	6.477
24	0.102	88	0.415	152	1.661	216	6.645
25	0.105	89	0.426	153	1.682	217	6.813
26	0.108	90	0.431	154	1.724	218	6.897
27	0.110	91	0.442	155	1.766	219	7.066
28	0.113	92	0.452	156	1.808	220	7.234
29	0.116	93	0.463	157	1.851	221	7.402
30	0.118	94	0.473	158	1.893	222	7.570
31	0.121	95	0.484	159	1.935	223	7.738
32	0.124	96	0.494	160	1.977	224	7.907
33	0.126	97	0.505	161	2.019	225	8.075
34	0.129	98	0.515	162	2.061	226	8.243
35	0.131	99	0.526	163	2.103	227	8.411
36	0.134	100	0.536	164	2.145	228	8.580
37	0.137	101	0.547	165	2.187	229	8.748
38	0.139	102	0.563	166	2.250	230	9.000
39	0.145	103	0.573	167	2.292	231	9.168
40	0.147	104	0.589	168	2.334	232	9.337
41	0.150	105	0.599	169	2.397	233	9.589
42	0.152	106	0.615	170	2.460	234	9.757
43	0.158	107	0.626	171	2.502	235	10.00
44	0.160	108	0.636	172	2.565		
45	0.163	109	0.652	173	2.608		
46	0.168	110	0.668	174	2.671		
47	0.171	111	0.683	175	2.733		
48	0.173	112	0.704	176	2.776		
49	0.179	113	0.715	177	2.860		
50	0.181	114	0.725	178	2.902		
51	0.187	115	0.747	179	2.986		
52	0.189	116	0.757	180	3.028		
53	0.195	117	0.778	181	3.112		
54	0.197	118	0.789	182	3.154		
55	0.202	119	0.810	183	3.238		
56	0.208	120	0.831	184	3.323		
57	0.210	121	0.852	185	3.365		
58	0.216	122	0.862	186	3.449		
59	0.221	123	0.883	187	3.533		
60	0.226	124	0.904	188	3.617		
61	0.231	125	0.925	189	3.701		
62	0.237	126	0.946	190	3.785		
63	0.242	127	0.967	191	3.869		

Table #21
VCM Phaser Speed

Data	Value	Data	Value	Data	Value	Data	Value
0	0.100	64	0.334	128	1.062	192	3.365
1	0.103	65	0.342	129	1.083	193	3.449
2	0.105	66	0.347	130	1.104	194	3.491
3	0.108	67	0.357	131	1.125	195	3.575
4	0.110	68	0.363	132	1.146	196	3.659
5	0.113	69	0.368	133	1.167	197	3.701
6	0.116	70	0.373	134	1.188	198	3.785
7	0.118	71	0.379	135	1.209	199	3.827
8	0.121	72	0.389	136	1.230	200	3.911
9	0.124	73	0.394	137	1.251	201	3.995
10	0.126	74	0.400	138	1.272	202	4.080
11	0.129	75	0.410	139	1.304	203	4.122
12	0.131	76	0.415	140	1.325	204	4.206
13	0.134	77	0.426	141	1.346	205	4.290
14	0.137	78	0.431	142	1.367	206	4.374
15	0.139	79	0.442	143	1.410	207	4.458
16	0.142	80	0.447	144	1.430	208	4.500
17	0.145	81	0.457	145	1.451	209	4.584
18	0.147	82	0.463	146	1.472	210	4.668
19	0.150	83	0.473	147	1.493	211	4.752
20	0.152	84	0.478	148	1.535	212	4.837
21	0.155	85	0.489	149	1.556	213	4.921
22	0.158	86	0.499	150	1.577	214	5.047
23	0.160	87	0.510	151	1.619	215	5.131
24	0.163	88	0.515	152	1.640	216	5.215
25	0.166	89	0.526	153	1.682	217	5.299
26	0.168	90	0.536	154	1.703	218	5.383
27	0.171	91	0.547	155	1.724	219	5.551
28	0.173	92	0.557	156	1.767	220	5.636
29	0.179	93	0.568	157	1.808	221	5.720
30	0.181	94	0.578	158	1.829	222	5.804
31	0.184	95	0.589	159	1.872	223	5.888
32	0.187	96	0.599	160	1.893	224	6.056
33	0.192	97	0.610	161	1.935	225	6.140
34	0.195	98	0.620	162	1.977	226	6.224
35	0.200	99	0.631	163	2.000	227	6.393
36	0.202	100	0.641	164	2.040	228	6.477
37	0.205	101	0.652	165	2.082	229	6.561
38	0.210	102	0.668	166	2.124	230	6.729
39	0.213	103	0.683	167	2.145	231	6.813
40	0.218	104	0.694	168	2.187	232	6.981
41	0.221	105	0.704	169	2.229	233	7.066
42	0.226	106	0.715	170	2.271	234	7.234
43	0.229	107	0.725	171	2.313	235	7.318
44	0.234	108	0.747	172	2.355	236	7.486
45	0.237	109	0.758	173	2.397	237	7.654
46	0.242	110	0.768	174	2.439	238	7.774
47	0.247	111	0.789	175	2.503	239	7.907
48	0.250	112	0.799	176	2.544	240	8.075
49	0.255	113	0.810	177	2.587	241	8.159
50	0.260	114	0.831	178	2.629	242	8.327
51	0.265	115	0.841	179	2.671	243	8.496
52	0.271	116	0.862	180	2.734	244	8.664
53	0.276	117	0.873	181	2.776	245	8.832
54	0.281	118	0.894	182	2.860	246	9.000
55	0.287	119	0.904	183	2.902	247	9.168
56	0.289	120	0.925	184	2.944	248	9.337
57	0.294	121	0.936	185	2.986	249	9.505
58	0.300	122	0.957	186	3.028	250	9.673
59	0.308	123	0.967	187	3.070	251	9.841
60	0.310	124	0.988	188	3.154	252	10.00
61	0.318	125	1.000	189	3.196		
62	0.323	126	1.030	190	3.280		
63	0.329	127	1.051	191	3.323		

Table #22
VCM Wah Speed

Data	Value	Data	Value	Data	Value	Data	Value
0	0.100	64	0.384	128	1.451	192	5.552
1	0.103	65	0.394	129	1.493	193	5.636
2	0.105	66	0.405	130	1.514	194	5.720
3	0.108	67	0.410	131	1.556	195	5.888
4	0.110	68	0.421	132	1.598	196	5.972
5	0.113	69	0.426	133	1.619	197	6.140
6	0.116	70	0.436	134	1.661	198	6.224
7	0.118	71	0.447	135	1.703	199	6.393
8	0.121	72	0.457	136	1.724	200	6.477
9	0.124	73	0.463	137	1.766	201	6.665
10	0.126	74	0.473	138	1.808	202	6.813
11	0.129	75	0.484	139	1.851	203	6.897
12	0.131	76	0.494	140	1.872	204	7.066
13	0.134	77	0.505	141	1.914	205	7.234
14	0.137	78	0.515	142	1.956	206	7.402
15	0.139	79	0.526	143	1.999	207	7.570
16	0.142	80	0.536	144	2.040	208	7.654
17	0.145	81	0.547	145	2.082	209	7.823
18	0.147	82	0.563	146	2.124	210	7.991
19	0.152	83	0.573	147	2.166	211	8.159
20	0.155	84	0.584	148	2.229	212	8.327
21	0.157	85	0.599	149	2.250	213	8.496
22	0.163	86	0.610	150	2.313	214	8.748
23	0.166	87	0.620	151	2.355	215	8.916
24	0.168	88	0.636	152	2.397	216	9.084
25	0.173	89	0.652	153	2.460	217	9.253
26	0.176	90	0.662	154	2.502	218	9.505
27	0.179	91	0.673	155	2.566	219	9.673
28	0.184	92	0.694	156	2.608	220	9.841
29	0.187	93	0.704	157	2.671	221	10.09
30	0.189	94	0.725	158	2.734	222	10.26
31	0.195	95	0.736	159	2.776	223	10.51
32	0.200	96	0.747	160	2.818	224	10.77
33	0.202	97	0.768	161	2.902	225	10.93
34	0.208	98	0.778	162	2.944	226	11.10
35	0.210	99	0.799	163	3.028	227	11.44
36	0.216	100	0.820	164	3.070	228	11.61
37	0.221	101	0.831	165	3.154	229	11.94
38	0.226	102	0.852	166	3.196	230	12.11
39	0.231	103	0.873	167	3.280	231	12.45
40	0.234	104	0.883	168	3.336	232	12.62
41	0.239	105	0.904	169	3.407	233	12.95
42	0.244	106	0.935	170	3.491	234	13.29
43	0.250	107	0.946	171	3.575	235	13.46
44	0.255	108	0.967	172	3.659	236	13.79
45	0.260	109	0.988	173	3.701	237	13.96
46	0.265	110	0.999	174	3.785	238	14.30
47	0.271	111	1.020	175	3.869	239	14.64
48	0.276	112	1.051	176	3.953	240	14.97
49	0.284	113	1.072	177	4.037	241	15.31
50	0.289	114	1.093	178	4.122	242	15.65
51	0.294	115	1.115	179	4.206	243	15.98
52	0.302	116	1.136	180	4.290	244	16.32
53	0.308	117	1.157	181	4.374	245	16.65
54	0.315	118	1.188	182	4.500	246	16.99
55	0.321	119	1.209	183	4.584	247	17.33
56	0.326	120	1.241	184	4.668	248	17.66
57	0.334	121	1.262	185	4.795	249	18.00
58	0.342	122	1.293	186	4.879	250	18.34
59	0.347	123	1.314	187	4.963	251	18.84
60	0.357	124	1.346	188	5.090	252	19.18
61	0.363	125	1.367	189	5.173	253	19.51
62	0.368	126	1.409	190	5.299	254	20.00
63	0.379	127	1.430	191	5.383		

Table #23
Rev Hall Time

Data	Value	Data	Value
0	0.3	64	13.5
1	0.4	65	14.0
2	0.5	66	15.0
3	0.6	67	16.0
4	0.7	68	17.0
5	0.8	69	18.0
6	0.9		
7	1.0		
8	1.1		
9	1.2		
10	1.3		
11	1.4		
12	1.5		
13	1.6		
14	1.7		
15	1.8		
16	1.9		
17	2.0		
18	2.1		
19	2.2		
20	2.3		
21	2.4		
22	2.5		
23	2.6		
24	2.7		
25	2.8		
26	2.9		
27	3.0		
28	3.1		
29	3.2		
30	3.3		
31	3.4		
32	3.5		
33	3.6		
34	3.7		
35	3.8		
36	3.9		
37	4.0		
38	4.1		
39	4.2		
40	4.3		
41	4.4		
42	4.5		
43	4.6		
44	4.7		
45	4.8		
46	4.9		
47	5.0		
48	5.5		
49	6.0		
50	6.5		
51	7.0		
52	7.5		
53	8.0		
54	8.5		
55	9.0		
56	9.5		
57	10.0		
58	10.5		
59	11.0		
60	11.5		
61	12.0		
62	12.5		
63	13.0		

Table #24
Rev Room Time

Data	Value	Data	Value
0	0.3	64	6.7
1	0.4	65	6.8
2	0.5	66	6.9
3	0.6	67	7.0
4	0.7	68	8.0
5	0.8	69	10.0
6	0.9		
7	1.0		
8	1.1		
9	1.2		
10	1.3		
11	1.4		
12	1.5		
13	1.6		
14	1.7		
15	1.8		
16	1.9		
17	2.0		
18	2.1		
19	2.2		
20	2.3		
21	2.4		
22	2.5		
23	2.6		
24	2.7		
25	2.8		
26	2.9		
27	3.0		
28	3.1		
29	3.2		
30	3.3		
31	3.4		
32	3.5		
33	3.6		
34	3.7		
35	3.8		
36	3.9		
37	4.0		
38	4.1		
39	4.2		
40	4.3		
41	4.4		
42	4.5		
43	4.6		
44	4.7		
45	4.8		
46	4.9		
47	5.0		
48	5.1		
49	5.2		
50	5.3		
51	5.4		
52	5.5		
53	5.6		
54	5.7		
55	5.8		
56	5.9		
57	6.0		
58	6.1		
59	6.2		
60	6.3		
61	6.4		
62	6.5		
63	6.6		

Table #25
VCM Comp Level

Data	Value	Data	Value	Data	Value	Data	Value
0	-∞dB	64	-29.69dB	128	-11.63dB	192	-1.06dB
1	-138.0dB	65	-29.29dB	129	-11.43dB	193	-0.93dB
2	-120.0dB	66	-28.89dB	130	-11.23dB	194	-0.79dB
3	-109.4dB	67	-28.50dB	131	-11.03dB	195	-0.66dB
4	-101.9dB	68	-28.11dB	132	-10.83dB	196	-0.53dB
5	-96.12dB	69	-27.73dB	133	-10.63dB	197	-0.39dB
6	-91.37dB	70	-27.36dB	134	-10.44dB	198	-0.26dB
7	-87.36dB	71	-26.99dB	135	-10.24dB	199	-0.13dB
8	-83.88dB	72	-26.62dB	136	-10.05dB	200	0.00dB
9	-80.81dB	73	-26.26dB	137	-9.86dB		
10	-78.06dB	74	-25.91dB	138	-9.67dB		
11	-75.58dB	75	-25.56dB	139	-9.48dB		
12	-73.31dB	76	-25.21dB	140	-9.29dB		
13	-71.23dB	77	-24.87dB	141	-9.11dB		
14	-69.29dB	78	-24.54dB	142	-8.92dB		
15	-67.50dB	79	-24.20dB	143	-8.74dB		
16	-65.81dB	80	-23.88dB	144	-8.56dB		
17	-64.23dB	81	-23.55dB	145	-8.38dB		
18	-62.75dB	82	-23.23dB	146	-8.20dB		
19	-61.34dB	83	-22.92dB	147	-8.02dB		
20	-60.00dB	84	-22.61dB	148	-7.85dB		
21	-58.73dB	85	-22.30dB	149	-7.67dB		
22	-57.52dB	86	-21.99dB	150	-7.50dB		
23	-56.36dB	87	-21.69dB	151	-7.32dB		
24	-55.25dB	88	-21.39dB	152	-7.15dB		
25	-54.19dB	89	-21.10dB	153	-6.98dB		
26	-53.16dB	90	-20.81dB	154	-6.81dB		
27	-52.18dB	91	-20.52dB	155	-6.64dB		
28	-51.23dB	92	-20.23dB	156	-6.47dB		
29	-50.32dB	93	-19.95dB	157	-6.31dB		
30	-49.43dB	94	-19.67dB	158	-6.14dB		
31	-48.58dB	95	-19.40dB	159	-5.98dB		
32	-47.75dB	96	-19.13dB	160	-5.81dB		
33	-46.95dB	97	-18.86dB	161	-5.65dB		
34	-46.17dB	98	-18.59dB	162	-5.49dB		
35	-45.42dB	99	-18.32dB	163	-5.33dB		
36	-44.68dB	100	-18.06dB	164	-5.17dB		
37	-43.97dB	101	-17.80dB	165	-5.01dB		
38	-43.27dB	102	-17.55dB	166	-4.86dB		
39	-42.60dB	103	-17.29dB	167	-4.70dB		
40	-41.94dB	104	-17.04dB	168	-4.54dB		
41	-41.29dB	105	-16.79dB	169	-4.39dB		
42	-40.67dB	106	-16.54dB	170	-4.23dB		
43	-40.05dB	107	-16.30dB	171	-4.08dB		
44	-39.45dB	108	-16.06dB	172	-3.93dB		
45	-38.87dB	109	-15.82dB	173	-3.78dB		
46	-38.30dB	110	-15.58dB	174	-3.63dB		
47	-37.74dB	111	-15.34dB	175	-3.48dB		
48	-37.19dB	112	-15.11dB	176	-3.33dB		
49	-36.65dB	113	-14.88dB	177	-3.18dB		
50	-36.12dB	114	-14.65dB	178	-3.04dB		
51	-35.61dB	115	-14.42dB	179	-2.89dB		
52	-35.10dB	116	-14.19dB	180	-2.75dB		
53	-34.61dB	117	-13.97dB	181	-2.60dB		
54	-34.12dB	118	-13.75dB	182	-2.46dB		
55	-33.64dB	119	-13.53dB	183	-2.31dB		
56	-33.17dB	120	-13.31dB	184	-2.17dB		
57	-32.71dB	121	-13.09dB	185	-2.03dB		
58	-32.26dB	122	-12.88dB	186	-1.89dB		
59	-31.81dB	123	-12.67dB	187	-1.75dB		
60	-31.37dB	124	-12.46dB	188	-1.61dB		
61	-30.94dB	125	-12.25dB	189	-1.47dB		
62	-30.52dB	126	-12.04dB	190	-1.34dB		
63	-30.10dB	127	-11.83dB	191	-1.20dB		

Table #26
VCM Comp Attack Time

Data	Value	Data	Value	Data	Value	Data	Value
0	0.022ms	64	2.941ms	128	16.53ms	192	45.51ms
1	0.023ms	65	3.056ms	129	16.86ms	193	46.10ms
2	0.024ms	66	3.174ms	130	17.18ms	194	46.70ms
3	0.025ms	67	3.295ms	131	17.52ms	195	47.31ms
4	0.026ms	68	3.418ms	132	17.85ms	196	47.91ms
5	0.028ms	69	3.544ms	133	18.19ms	197	48.53ms
6	0.031ms	70	3.673ms	134	18.53ms	198	49.15ms
7	0.035ms	71	3.805ms	135	18.88ms	199	49.77ms
8	0.039ms	72	3.940ms	136	19.23ms	200	50.40ms
9	0.045ms	73	4.077ms	137	19.59ms		
10	0.051ms	74	4.217ms	138	19.95ms		
11	0.059ms	75	4.361ms	139	20.31ms		
12	0.068ms	76	4.507ms	140	20.68ms		
13	0.077ms	77	4.656ms	141	21.05ms		
14	0.088ms	78	4.807ms	142	21.42ms		
15	0.101ms	79	4.962ms	143	21.80ms		
16	0.114ms	80	5.120ms	144	22.18ms		
17	0.129ms	81	5.281ms	145	22.57ms		
18	0.146ms	82	5.445ms	146	22.96ms		
19	0.163ms	83	5.611ms	147	23.36ms		
20	0.182ms	84	5.781ms	148	23.75ms		
21	0.203ms	85	5.954ms	149	24.16ms		
22	0.225ms	86	6.130ms	150	24.56ms		
23	0.249ms	87	6.309ms	151	24.97ms		
24	0.274ms	88	6.491ms	152	25.39ms		
25	0.301ms	89	6.677ms	153	25.81ms		
26	0.330ms	90	6.865ms	154	26.23ms		
27	0.360ms	91	7.057ms	155	26.66ms		
28	0.393ms	92	7.252ms	156	27.09ms		
29	0.426ms	93	7.450ms	157	27.53ms		
30	0.462ms	94	7.651ms	158	27.97ms		
31	0.500ms	95	7.855ms	159	28.41ms		
32	0.539ms	96	8.063ms	160	28.86ms		
33	0.580ms	97	8.274ms	161	29.31ms		
34	0.623ms	98	8.489ms	162	29.77ms		
35	0.668ms	99	8.706ms	163	30.23ms		
36	0.716ms	100	8.927ms	164	30.70ms		
37	0.765ms	101	9.151ms	165	31.17ms		
38	0.816ms	102	9.379ms	166	31.64ms		
39	0.869ms	103	9.610ms	167	32.12ms		
40	0.924ms	104	9.844ms	168	32.60ms		
41	0.982ms	105	10.09ms	169	33.09ms		
42	1.041ms	106	10.33ms	170	33.58ms		
43	1.103ms	107	10.57ms	171	34.07ms		
44	1.167ms	108	10.82ms	172	34.57ms		
45	1.233ms	109	11.07ms	173	35.08ms		
46	1.301ms	110	11.33ms	174	35.59ms		
47	1.372ms	111	11.59ms	175	36.10ms		
48	1.444ms	112	11.85ms	176	36.62ms		
49	1.520ms	113	12.11ms	177	37.14ms		
50	1.597ms	114	12.38ms	178	37.67ms		
51	1.677ms	115	12.66ms	179	38.20ms		
52	1.759ms	116	12.93ms	180	38.73ms		
53	1.844ms	117	13.21ms	181	39.27ms		
54	1.931ms	118	13.50ms	182	39.82ms		
55	2.021ms	119	13.78ms	183	40.36ms		
56	2.113ms	120	14.07ms	184	40.92ms		
57	2.207ms	121	14.37ms	185	41.48ms		
58	2.304ms	122	14.67ms	186	42.04ms		
59	2.404ms	123	14.97ms	187	42.61ms		
60	2.506ms	124	15.27ms	188	43.18ms		
61	2.611ms	125	15.58ms	189	43.75ms		
62	2.718ms	126	15.90ms	190	44.33ms		
63	2.828ms	127	16.21ms	191	44.92ms		

Table #27
VCM Comp Release Time

Data	Value	Data	Value	Data	Value	Data	Value
0	10.88ms	64	65.50ms	128	229.34ms	192	502.40ms
1	10.90ms	65	67.22ms	129	232.76ms	193	507.54ms
2	10.94ms	66	68.96ms	130	236.22ms	194	512.70ms
3	11.00ms	67	70.74ms	131	239.70ms	195	517.88ms
4	11.10ms	68	72.54ms	132	243.20ms	196	523.10ms
5	11.22ms	69	74.36ms	133	246.74ms	197	528.34ms
6	11.36ms	70	76.22ms	134	250.30ms	198	533.60ms
7	11.54ms	71	78.10ms	135	253.88ms	199	538.90ms
8	11.74ms	72	80.00ms	136	257.50ms	200	544.22ms
9	11.96ms	73	81.94ms	137	261.14ms		
10	12.22ms	74	83.90ms	138	264.80ms		
11	12.50ms	75	85.88ms	139	268.50ms		
12	12.80ms	76	87.90ms	140	272.22ms		
13	13.14ms	77	89.94ms	141	275.96ms		
14	13.50ms	78	92.00ms	142	279.74ms		
15	13.88ms	79	94.10ms	143	283.54ms		
16	14.30ms	80	96.22ms	144	287.36ms		
17	14.74ms	81	98.36ms	145	291.22ms		
18	15.20ms	82	100.54ms	146	295.10ms		
19	15.70ms	83	102.74ms	147	299.00ms		
20	16.22ms	84	104.96ms	148	302.94ms		
21	16.76ms	85	107.22ms	149	306.90ms		
22	17.34ms	86	109.50ms	150	310.88ms		
23	17.94ms	87	111.80ms	151	314.90ms		
24	18.56ms	88	114.14ms	152	318.94ms		
25	19.22ms	89	116.50ms	153	323.00ms		
26	19.90ms	90	118.88ms	154	327.10ms		
27	20.60ms	91	121.30ms	155	331.22ms		
28	21.34ms	92	123.74ms	156	335.36ms		
29	22.10ms	93	126.20ms	157	339.54ms		
30	22.88ms	94	128.70ms	158	343.74ms		
31	23.70ms	95	131.22ms	159	347.96ms		
32	24.54ms	96	133.76ms	160	352.22ms		
33	25.40ms	97	136.34ms	161	356.50ms		
34	26.30ms	98	138.94ms	162	360.80ms		
35	27.22ms	99	141.56ms	163	365.14ms		
36	28.16ms	100	144.22ms	164	369.50ms		
37	29.14ms	101	146.90ms	165	373.88ms		
38	30.14ms	102	149.60ms	166	378.30ms		
39	31.16ms	103	152.34ms	167	382.74ms		
40	32.22ms	104	155.10ms	168	387.20ms		
41	33.30ms	105	157.88ms	169	391.70ms		
42	34.40ms	106	160.70ms	170	396.22ms		
43	35.54ms	107	163.54ms	171	400.76ms		
44	36.70ms	108	166.40ms	172	405.34ms		
45	37.88ms	109	169.30ms	173	409.94ms		
46	39.10ms	110	172.22ms	174	414.56ms		
47	40.34ms	111	175.16ms	175	419.22ms		
48	41.60ms	112	178.14ms	176	423.90ms		
49	42.90ms	113	181.14ms	177	428.60ms		
50	44.22ms	114	184.16ms	178	433.34ms		
51	45.56ms	115	187.22ms	179	438.10ms		
52	46.94ms	116	190.30ms	180	442.88ms		
53	48.34ms	117	193.40ms	181	447.70ms		
54	49.76ms	118	196.54ms	182	452.54ms		
55	51.22ms	119	199.70ms	183	457.40ms		
56	52.70ms	120	202.88ms	184	462.30ms		
57	54.20ms	121	206.10ms	185	467.22ms		
58	55.74ms	122	209.34ms	186	472.16ms		
59	57.30ms	123	212.60ms	187	477.14ms		
60	58.88ms	124	215.90ms	188	482.14ms		
61	60.50ms	125	219.22ms	189	487.16ms		
62	62.14ms	126	222.56ms	190	492.22ms		
63	63.80ms	127	225.94ms	191	497.30ms		

Table #28
VCM EQ Frequency

Data	Value	Data	Value	Data	Value
0	16.0Hz	64	630Hz	128	25.0kHz
1	17.0Hz	65	670Hz	129	26.5kHz
2	18.0Hz	66	710Hz	130	28.0kHz
3	19.0Hz	67	750Hz	131	30.0kHz
4	20.0Hz	68	800Hz	132	31.5kHz
5	21.2Hz	69	850Hz	133	33.5kHz
6	22.4Hz	70	900Hz	134	35.5kHz
7	23.6Hz	71	950Hz	135	37.5kHz
8	25.0Hz	72	1.00kHz	136	40.0kHz
9	26.5Hz	73	1.06kHz		
10	28.0Hz	74	1.12kHz		
11	30.0Hz	75	1.18kHz		
12	31.5Hz	76	1.25kHz		
13	33.5Hz	77	1.32kHz		
14	35.5Hz	78	1.40kHz		
15	37.5Hz	79	1.50kHz		
16	40.0Hz	80	1.60kHz		
17	42.5Hz	81	1.70kHz		
18	45.0Hz	82	1.80kHz		
19	47.5Hz	83	1.90kHz		
20	50.0Hz	84	2.00kHz		
21	53.0Hz	85	2.12kHz		
22	56.0Hz	86	2.24kHz		
23	60.0Hz	87	2.36kHz		
24	63.0Hz	88	2.50kHz		
25	67.0Hz	89	2.65kHz		
26	71.0Hz	90	2.80kHz		
27	75.0Hz	91	3.00kHz		
28	80.0Hz	92	3.15kHz		
29	85.0Hz	93	3.35kHz		
30	90.0Hz	94	3.55kHz		
31	95.0Hz	95	3.75kHz		
32	100Hz	96	4.00kHz		
33	106Hz	97	4.25kHz		
34	112Hz	98	4.50kHz		
35	118Hz	99	4.75kHz		
36	125Hz	100	5.00kHz		
37	132Hz	101	5.30kHz		
38	140Hz	102	5.60kHz		
39	150Hz	103	6.00kHz		
40	160Hz	104	6.30kHz		
41	170Hz	105	6.70kHz		
42	180Hz	106	7.10kHz		
43	190Hz	107	7.50kHz		
44	200Hz	108	8.00kHz		
45	212Hz	109	8.50kHz		
46	224Hz	110	9.00kHz		
47	236Hz	111	9.50kHz		
48	250Hz	112	10.0kHz		
49	265Hz	113	10.6kHz		
50	280Hz	114	11.2kHz		
51	300Hz	115	11.8kHz		
52	315Hz	116	12.5kHz		
53	335Hz	117	13.2kHz		
54	355Hz	118	14.0kHz		
55	375Hz	119	15.0kHz		
56	400Hz	120	16.0kHz		
57	425Hz	121	17.0kHz		
58	450Hz	122	18.0kHz		
59	475Hz	123	19.0kHz		
60	500Hz	124	20.0kHz		
61	530Hz	125	21.2kHz		
62	560Hz	126	22.4kHz		
63	600Hz	127	23.6kHz		

Table #29
VCM EQ Q

Data	Value
0	0.50
1	0.53
2	0.56
3	0.59
4	0.63
5	0.67
6	0.71
7	0.75
8	0.79
9	0.84
10	0.89
11	0.94
12	1.00
13	1.06
14	1.12
15	1.19
16	1.26
17	1.33
18	1.41
19	1.50
20	1.59
21	1.68
22	1.78
23	1.89
24	2.00
25	2.12
26	2.24
27	2.38
28	2.52
29	2.67
30	2.83
31	3.00
32	3.17
33	3.36
34	3.56
35	3.78
36	4.00
37	4.24
38	4.49
39	4.76
40	5.04
41	5.34
42	5.66
43	5.99
44	6.35
45	6.73
46	7.13
47	7.55
48	8.00
49	8.48
50	8.98
51	9.51
52	10.08
53	10.68
54	11.31
55	11.99
56	12.70
57	13.45
58	14.25
59	15.10
60	16.00

Mixing Template List

No.	Name
1	Contemporary R&B
2	Flip Hop
3	Hip Hop 1
4	Hip Hop 2
5	Disco
6	Funk 1
7	Funk 2
8	70's Rock
9	Soft Rock
10	Unplugged
11	PianoClub
12	Cool Funk
13	Analog Pop
14	Guitar Pop
15	Slowfeel
16	Combo Jazz
17	Samba
18	Salsa
19	Montuno
20	Reggae
21	Trance
22	IbizaTrance
23	DreamDance
24	Synth Pop
25	Chill Out
26	Club House
27	LatinHouse
28	Garage
29	Retro Pop
30	Xover Rock
31	Spanish Pop
32	TurkishPop

Remote Control Assignments

DAW

Cubase	Cubase 5.5 or later; Cubase Studio 5.5 or later; Cubase Essential 5.1.1 or later; Cubase AI5.1.1 or later
Logic	Logic Pro 9
SONAR	SONAR 8
Digital Performer	Digital Performer 6, 7

Remote Control Function

	Cubase	Logic	SONAR	Digital Performer
BANK SELECT [DEC]/[INC]	Changes the Control Template	←	←	←
Knob Function 1	Changes the functions assigned to Knobs 1 – 4.	←	←	←
Knob Function 2	Changes the functions assigned to Knobs 5 – 8.	—	—	—
SEQ TRANSPORT Top	Returns to the beginning of the song	←	←	←
SEQ TRANSPORT Rewind	Rewinds through the song	←	←	←
SEQ TRANSPORT Forward	Fast-forwards through the song	←	←	←
SEQ TRANSPORT Stop	Stops recording or playback	←	←	←
SEQ TRANSPORT Play	Starts playback from the current point	←	←	←
SEQ TRANSPORT Rec	Starts song recording	←	←	←
[F1]	Opens/closes the [Add Instrument Track] dialog.	Mackie Control F1	Mackie Control F1	—
[F2]	Opens/closes the VSTi display for the selected Track.	Mackie Control F2	Mackie Control F2	—
[F3]	Opens/closes the settings window for the channel of the selected Track.	Mackie Control F3	Mackie Control F3	—
[F4]	Switches Automation Read for the selected Track on or off.	Mackie Control F4	Mackie Control F4	—
[F5]	Switches Automation Write for the selected Track on or off.	Mackie Control F5	Mackie Control F5	—
[F6]	Delete	Mackie Control F6	Mackie Control F6	—
[SF1] – [SF6]	Assignable functions For information on the default functions, refer to the "Reference Manual" PDF document.	Mackie Control F7 – F12	Mackie Control F7 – F12	—
MUTE	Turns Mute on or off for the selected track	—	—	—
SOLO	Turns Solo on or off for the selected track	—	—	—
EXIT	Escape key on computer keyboard	←	←	←
ENTER	Enter key on computer keyboard	←	←	←
Cursor button	Cursor key on computer keyboard	←	←	←
[INC]/[DEC]	Changes the Program	←	←	←
Number [1] – [10]	Numeric keys on computer keyboard	←	←	←
Number [14] – [16]	“.” (period), “-” (minus), “+” (plus) on computer keyboard	←	←	←
[DATA] dial	Operates the parameter specified via the mouse pointer (when the [JOG]/[LOCK] button is set to off). Functions as AI KNOB (when the [JOG]/[LOCK] button is set to on).	—	—	—
[UTILITY]	Calls up the display for the Utility settings dedicated to the Remote mode	←	←	←
[A] – [F]	Changes Memory 1 – 6, which are assigned to the [SF1] – [SF6] buttons in the MOX6/ MOX8 Extension Setup window.	—	—	—

Control List

Controller Set Destination

No.	Parameter		Voice	Drum
0	off	Common	O	O
1	Insertion Effect A Parameter 1	:	O	O
	:			
16	Insertion Effect A Parameter 16	:	O	O
17	Insertion Effect B Parameter 1	:	O	O
	:			
32	Insertion Effect B Parameter 16	:	O	O
33	Insertion Effect L Parameter 1	:	O	-
	:			
64	Insertion Effect L Parameter 32	:	O	-
65	Volume	:	O	O
66	Reverb Send	:	O	O
67	Chorus Send	:	O	O
68	Common LFO Speed	:	O	-
69	Common LFO Depth 1	:	O	-
70	Common LFO Depth 2	:	O	-
71	Common LFO Depth 3	:	O	-
72	Portamento Time	:	O	-
73	Element Level	Element	O	-
74	Element Pan	:	O	-
75	Key On Delay Time	:	O	-
76	Element LFO Speed	:	O	-
77	Element LFO PMD	:	O	-
78	Element LFO AMD	:	O	-
79	Element LFO FMD	:	O	-
80	Coarse Tune	:	O	-
81	Fine Tune	:	O	-
82	PEG Depth	:	O	-
83	PEG Hold Time	:	O	-
84	PEG Attack Time	:	O	-
85	PEG Decay 1 Time	:	O	-
86	PEG Decay 2 Time	:	O	-
87	PEG Release Time	:	O	-
88	AEG Attack Time	:	O	-
89	AEG Decay 1 Time	:	O	-
90	AEG Decay 2 Time	:	O	-
91	AEG Release Time	:	O	-
92	FEG Depth	:	O	-
93	FEG Hold Time	:	O	-
94	FEG Attack Time	:	O	-
95	FEG Decay 1 Time	:	O	-
96	FEG Decay 2 Time	:	O	-
97	FEG Release Time	:	O	-
98	Cutoff Frequency	:	O	-
99	Resonance	:	O	-
100	HPF Cutoff Frequency	:	O	-
101	Mono/Poly	Common	O	-

LFO Box Destination

No.	Parameter	
0	Insertion Effect A Parameter 1	Common
	:	
15	Insertion Effect A Parameter 16	:
16	Insertion Effect B Parameter 1	:
	:	
31	Insertion Effect B Parameter 16	:
32	Insertion Effect L Parameter 1	:
	:	
63	Insertion Effect L Parameter 32	:
64	Amplitude Modulation	Element
65	Pitch Modulation	:
66	Filter Modulation	:
67	Resonance	:
68	Element Pan	:
69	Element LFO Speed	:

MIDI Data Format

Many MIDI messages listed in the MIDI Data Format section are expressed in hexadecimal or binary numbers. Hexadecimal numbers may include the letter "H" as a suffix. The letter "n" indicates a certain whole number.

The chart below lists the corresponding decimal number for each hexadecimal number.

Decimal	Hexadecimal	Decimal	Hexadecimal
0	0	64	40
1	1	65	41
2	2	66	42
3	3	67	43
4	4	68	44
5	5	69	45
6	6	70	46
7	7	71	47
8	8	72	48
9	9	73	49
10	0A	74	4A
11	0B	75	4B
12	0C	76	4C
13	0D	77	4D
14	0E	78	4E
15	0F	79	4F
16	10	80	50
17	11	81	51
18	12	82	52
19	13	83	53
20	14	84	54
21	15	85	55
22	16	86	56
23	17	87	57
24	18	88	58
25	19	89	59
26	1A	90	5A
27	1B	91	5B
28	1C	92	5C
29	1D	93	5D
30	1E	94	5E
31	1F	95	5F
32	20	96	60
33	21	97	61
34	22	98	62
35	23	99	63
36	24	100	64
37	25	101	65
38	26	102	66
39	27	103	67
40	28	104	68
41	29	105	69
42	2A	106	6A
43	2B	107	6B
44	2C	108	6C
45	2D	109	6D
46	2E	110	6E
47	2F	111	6F
48	30	112	70
49	31	113	71
50	32	114	72
51	33	115	73
52	34	116	74
53	35	117	75
54	36	118	76
55	37	119	77
56	38	120	78
57	39	121	79
58	3A	122	7A
59	3B	123	7B
60	3C	124	7C
61	3D	125	7D
62	3E	126	7E
63	3F	127	7F

Additional Notes

- For example, 144 – 159(Decimal)/9nH/1001 0000 – 1001 1111(Binary) indicate the note-on messages for the channels 1 through 16 respectively. 176 – 191/BnH/1011 0000 – 1011 1111 indicate the control change messages for the channels 1 through 16 respectively. 192 – 207/CnH/1100 0000 – 1100 1111 indicate the program change messages for the channels 1 through 16 respectively. 240/F0H/1111 0000 is positioned at the beginning of data to indicate a system exclusive message. 247/F7H/1111 0111 is positioned at the end of the system exclusive message.
- aaH (Hexadecimal)/0aaaaaaa (Binary) indicates the data addresses. The data address consists of High, Mid and Low.
- bbH/0bbbbbbb indicates byte counts.
- ccH/0ccccccc indicates check sums.
- ddH/0ddddddd indicates data/value.

SYNTHESIZER/SEQUENCER PART

(1) TRANSMIT FLOW

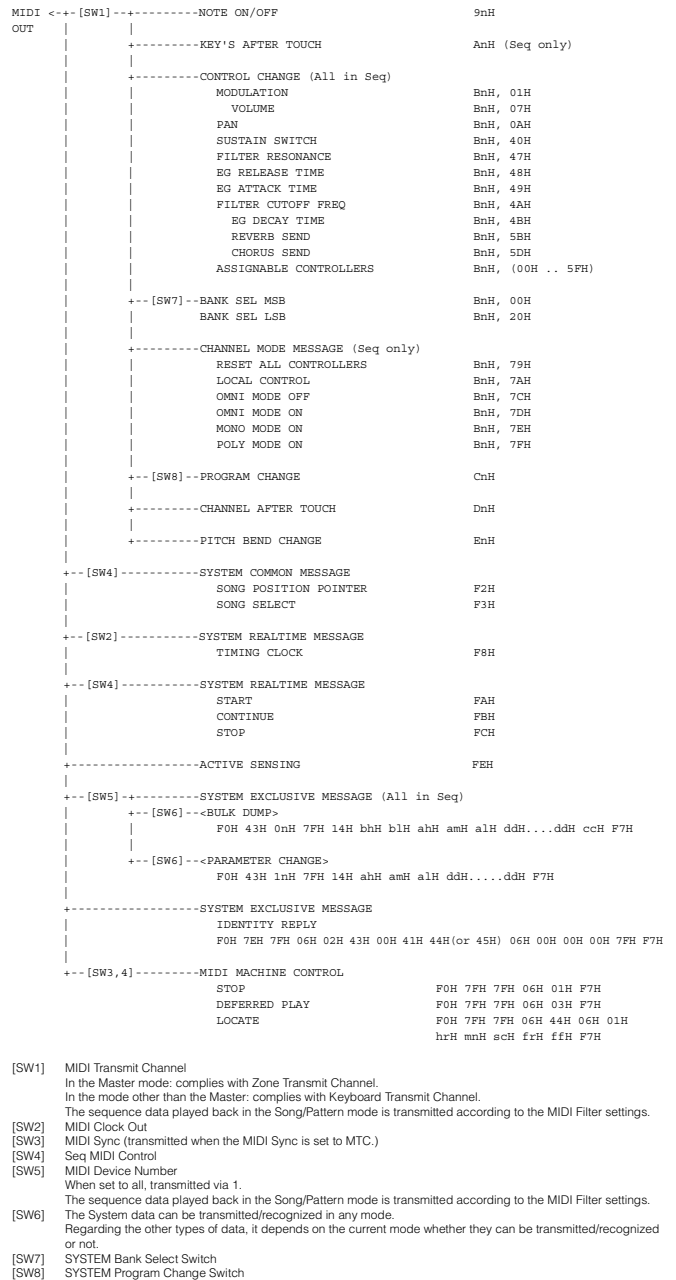

(2) RECEIVE FLOW

```

MIDI>-- [SW10]-----NOTE OFF                8nH
-----NOTE ON/OFF                            9nH
-----KEY'S AFTER TOUCH                      AnH (Seq only)
-----CONTROL CHANGE (All in Seq)
  MODULATION                                BnH, 01H
  PORTAMENTO TIME                            BnH, 05H
  DATA ENTRY MSB                           BnH, 06H
  DATA ENTRY LSB                           BnH, 26H
  MAIN VOLUME                               BnH, 07H
  PAN                                        BnH, 0AH
  EXPRESSION                                 BnH, 0BH
  EG SUSTAIN LEVEL                           BnH, 1FH
  SUSTAIN SWITCH                             BnH, 40H
  PORTAMENTO SWITCH                           BnH, 41H
  SOSTENUTO                                  BnH, 42H
  HARMONIC CONTENT                           BnH, 47H
  EG RELEASE TIME                            BnH, 48H
  EG ATTACK TIME                             BnH, 49H
  BRIGHTNESS                                 BnH, 4AH
  EG DECAY TIME                              BnH, 4BH
  EFFECT1 DEPTH                              BnH, 5BH
  EFFECT3 DEPTH                              BnH, 5DH
  DATA ENTRY INC                             BnH, 60H
  DATA ENTRY DEC                             BnH, 61H
  ALL SOUND OFF                              BnH, 78H
  ASSIGNABLE CONTROLLER                      BnH, (00H .. 5FH)
  RPN
    PITCH BEND SENS.                         BnH, 64H, 00H, 65H, 00H, 06H,
    mmH
    FINE TUNING                              BnH, 64H, 01H, 65H, 00H, 06H,
    mmH, 26H, 11H
    COARSE TUNING                           BnH, 64H, 02H, 65H, 00H, 06H,
    mmH
    RPN RESET                               BnH, 64H, 7FH, 65H, 7FH

-- [SW7]--BANK SEL MSB                       BnH, 00H
  BANK SEL LSB                              BnH, 20H

-----CHANNEL MODE MESSAGE
  RESET ALL CONTROLLERS                     BnH, 79H
  OMNI MODE OFF                             BnH, 7CH
  OMNI MODE ON                              BnH, 7DH
  MONO MODE ON                              BnH, 7EH
  POLY MODE ON                              BnH, 7FH

-- [SW8]--PROGRAM CHANGE                     CnH

-----CHANNEL AFTER TOUCH                     DnH

-----PITCH BEND CHANGE                       EnH

-- [SW3]-----SYSTEM COMMON MESSAGE
  MTC QUARTER FRAME MESSAGE                 F1H

-- [SW4]-----SYSTEM COMMON MESSAGE
  SONG POSITION POINTER                       F2H
  SONG SELECT                               F3H

-- [SW3]-----SYSTEM REALTIME MESSAGE
  TIMING CLOCK                              F8H

-- [SW4]-----SYSTEM REALTIME MESSAGE
  START                                     FAH
  CONTINUE                                  FBH
  STOP                                      FCH

-----ACTIVE SENSING                         FEH

-- [SW5]-----SYSTEM EXCLUSIVE MESSAGE (All in Seq)
  MIDI MASTER VOLUME                        FOH 7FH 7FH 04H 01H 11H mmH F7H

-- [SW9]--<BULK DUMP>
  FOH 43H 0nH 7FH 14H bhH b1H ahH amH a1H ddH....ddH ccH F7H

-- [SW6]--<PARAMETER CHANGE>
  FOH 43H 1nH 7FH 14H ahH amH a1H ddH....ddH F7H

-- [SW6]--<BULK DUMP REQUEST>
  FOH 43H 2nH 7FH 14H ahH amH a1H ddH....ddH F7H

-- [SW6]--<PARAMETER REQUEST>
  FOH 43H 3nH 7FH 14H ahH amH a1H F7H

-- [SW11]--GM MODE ON
  FOH 7EH 7FH 09H 01H F7H

-----SYSTEM EXCLUSIVE MESSAGE
  IDENTITY REQUEST                          FOH 7EH 0nH 06H 01H F7H
  SECTION CONTROL                           FOH 43H 7EH 00H ssH ddH F7H
  (Pattern Mode only)
  
```

[SW3] MIDI Sync (can be set to "internal," "MIDI," or "MTC")
 [SW4] Seq MIDI Control
 [SW5] MIDI Device Number
 When this is not set to off, the MIDI Master Volume can be recognized in any mode.
 The sequence data played back in the Song/Pattern mode is transmitted according to the MIDI Filter settings.
 [SW6] The system data can be transmitted/recognized in any mode.
 [SW7] SYSTEM Bank Select Switch
 [SW8] SYSTEM Program Change Switch
 [SW9] SYSTEM Bulk Protect and same as SW6.
 [SW10] MIDI Receive Channel and Receive Filter.
 In the Song/Pattern mode: complies with Part Receive Channel and Part Receive Switch.
 In the other mode: complies with Basic Receive Channel.
 The sequence data played back in the Song/Pattern mode is transmitted according to the MIDI Filter settings.
 [SW11] Recognized only in the Song/Pattern mode.

(3) TRANSMIT/RECEIVE DATA

(3-1) CHANNEL VOICE MESSAGES

(3-1-1) NOTE OFF

```

STATUS          1000nnnn (8nH)          n = 0 - 15 CHANNEL NUMBER
NOTE No.        0kkkkkkk                k = 0 (C-2) - 127 (G8)
VELOCITY        0vvvvvvv                v: ignored
Receive only
  
```

(3-1-2) NOTE ON/OFF

```

STATUS          1001nnnn (9nH)          n = 0 - 15 CHANNEL NUMBER
NOTE NUMBER     0kkkkkkk                k = 0 (C-2) - 127 (G8)
VELOCITY NOTE ON 0vvvvvvv (v≠0)
NOTE OFF        0vvvvvvv (v=0)
  
```

(3-1-3) CONTROL CHANGE

```

STATUS          1011nnnn (BnH)          n = 0 - 15 CHANNEL NUMBER
CONTROL NUMBER  0ccccccc
CONTROL VALUE   0vvvvvvv
  
```

* TRANSMITTED CONTROL NUMBER

c = 0	BANK SEL MSB	; v = 0 - 127	*3
c = 32	BANK SEL LSB	; v = 0 - 127	*3
c = 1	MODULATION	; v = 0 - 127	
c = 7	MAIN VOLUME	; v = 0 - 127	
c = 10	PAN	; v = 0 - 127	
c = 11	EXPRESSION	; v = 0 - 127	
c = 31	EG SUSTAIN LEVEL	; v = 0: -64 - 64: 0 - 127: +63	
c = 64	SUSTAIN	; v = 0 - 127	*6
c = 71	FILTER RESONANCE	; v = 0: -64 - 64: 0 - 127: +63	
c = 72	EG RELEASE TIME	; v = 0: -64 - 64: 0 - 127: +63	
c = 73	EG ATTACK TIME	; v = 0: -64 - 64: 0 - 127: +63	
c = 74	FILTER CUTOFF FREQ	; v = 0: -64 - 64: 0 - 127: +63	
c = 75	EG DECAY TIME	; v = 0: -64 - 64: 0 - 127: +63	
c = 91	REVERB SEND	; v = 0, 127	
c = 93	CHORUS SEND	; v = 0, 127	
c = 0..95	ASSIGNABLE CONTROLLERS	; v = 0 - 127	*4

The Sequencer Part will play back all recorded control change messages.

* RECEIVED CONTROL NUMBER

c = 0	BANK SEL MSB	; v = 0 - 127	*3
c = 32	BANK SEL LSB	; v = 0 - 127	*3
c = 1	MODULATION	; v = 0 - 127	
c = 5	PORTAMENTO TIME	; v = 0 - 127	*2
c = 6	DATA ENTRY MSB	; v = 0 - 127	*1
c = 38	DATA ENTRY LSB	; v = 0 - 127	*1
c = 7	MAIN VOLUME	; v = 0 - 127	
c = 10	PAN	; v = 0 - 127	
c = 11	EXPRESSION	; v = 0 - 127	
c = 31	EG SUSTAIN LEVEL	; v = 0: -64 - 64: 0 - 127: +63	*2
c = 64	SUSTAIN	; v = 0 - 127	
c = 65	PORTAMENTO SWITCH	; v = 0 - 63: OFF, 64 - 127: ON	*2
c = 66	SOSTENUTO	; v = 0 - 63: OFF, 64 - 127: ON	
c = 71	HARMONIC CONTENT	; v = 0: -64 - 64: 0 - 127: +63	
c = 72	EG RELEASE TIME	; v = 0: -64 - 64: 0 - 127: +63	*2
c = 73	EG ATTACK TIME	; v = 0: -64 - 64: 0 - 127: +63	
c = 74	BRIGHTNESS	; v = 0: -64 - 64: 0 - 127: +63	
c = 75	EG DECAY TIME	; v = 0: -64 - 64: 0 - 127: +63	
c = 91	EFFECT1 DEPTH	; v = 0 - 127	
c = 93	EFFECT3 DEPTH	; v = 0 - 127	
c = 96	DATA ENTRY INC	; v = 127	*1
c = 97	DATA ENTRY DEC	; v = 127	*1
c = 0..95	ASSIGNABLE CONTROLLER	; v = 0 - 127	*4
c = 0..95	ARPEGGIO SW	; v = 0 - 63: OFF, 64 - 127: ON	*4
c = 0..95	ARPEGGIO HOLD	; v = 0 - 63: OFF, 64 - 127: ON	*4

All Control Change events can be recorded to the Song/Pattern.

*1 Used only when a value is set using RPN.
 *2 Invalid with Drum Voices.
 *3 Relation between BANK CHANGE and PROGRAM is as follows:

CATEGORY	MSB	LSB	PROGRAM No. (display)
GM Voice	0	0	0..127 (1..128)
GM Drum Voice	127	0	0..1 (1..2)
Normal Voice Preset 1	63	0	0..127 (1..128)
Preset 2	63	1	0..127 (1..128)
Preset 3	63	2	0..127 (1..128)
Preset 4	63	3	0..127 (1..128)
User 1	63	8	0..127 (1..128)
User 2	63	9	0..127 (1..128)
Drum Voice Preset	63	32	0..63 (1..64)
User	63	40	0..31 (1..32)
Performance User 1	63	64	0..127 (1..128)
Performance User 2	63	65	0..127 (1..128)
Mixing Voice	63	60	0..15 (1..16)

*4 The default CONTROL NUMBERS of ASSIGNABLE CONTROLLER are as follows:
 BREATH CONTROLLER 2
 FOOT CONTROLLER 4
 ASSIGN 1 16
 ASSIGN 2 17
 FOOT SWITCH 96

*5 Can be selected only in the Song/Pattern mode. Up to 16 Mixing Voices are available in a Song/Pattern.

*6 When the sustain pedal is set to something other than "FC3 (Half On)," operating the sustain pedal transmits only values of 0 (off) or 127 (on).

PORTAMENTO TIME sets the time it takes for the pitch to reach the next note played when PORTAMENTO SWITCH is set to on.
 PAN position relatively changes according to the preset value for each voice.
 EFFECT1 DEPTH controls reverb send level.
 EFFECT3 DEPTH controls chorus send level.
 HARMONIC CONTENT adjusts the resonance preset for each voice. Setting a value adds to or subtracts from the center value, 64, since it is an offset parameter.
 The larger the value more resonant sound will be produced.
 The effective range may be narrower than the range you can designate depending on the selected voice.
 The parameters, EG ATTACK TIME, EG DECAY TIME, EG SUSTAIN LEVEL, EG RELEASE TIME adjust the envelopes preset for each voice. Setting these values add to or subtract from the center value, 64, since these are offset parameters.
 BRIGHTNESS adjusts the cutoff frequency preset for each voice. Setting a value adds to or subtracts from the center value, 64, since it is an offset parameter. The smaller the value the cutoff frequency will be lowered. The effective range may be narrower than the range you can designate depending on the selected voice.
 Bank Select will be actually executed when the Program Change message is received. Bank Select and Program Change numbers that are not supported by Yamaha will be ignored.

(3-1-4) PROGRAM CHANGE

STATUS	1100nnnn (CnH)	n = 0 - 15 CHANNEL NUMBER
PROGRAM NUMBER	0ppppppp	p = 0 - 127

(3-1-5) CHANNEL AFTER TOUCH

STATUS	1101nnnn (DnH)	n = 0 - 15 CHANNEL NUMBER
VALUE	0vvvvvvv	v = 0 - 127 AFTER TOUCH VALUE

(3-1-6) PITCH BEND CHANGE

STATUS	1110nnnn (EnH)	n = 0 - 15 CHANNEL NUMBER
LSB	0vvvvvvv	PITCH BEND CHANGE LSB
MSB	0vvvvvvv	PITCH BEND CHANGE MSB

Transmitted with a resolution of 7 bits.

(3-2) CHANNEL MODE MESSAGES

STATUS	1011nnnn (BnH)	n = 0 - 15 CHANNEL NUMBER
CONTROL NUMBER	0ccccccc	c = CONTROL NUMBER
CONTROL VALUE	0vvvvvvv	v = DATA VALUE

(3-2-1) ALL SOUND OFF (CONTROL NUMBER = 78H, DATA VALUE = 0)

All the sounds currently played including the channel messages such as note-on and hold-on in a certain channel are muted when receiving this message.

(3-2-2) RESET ALL CONTROLLERS (CONTROL NUMBER = 79H, DATA VALUE = 0)

Resets the values set for the following controllers.

PITCH BEND CHANGE	0 (center)
CHANNEL AFTER TOUCH	0 (minimum)
MODULATION	0 (minimum)
EXPRESSION	127 (maximum)
BREATH CONTROLLER	127 (maximum)
FOOT CONTROLLER 1	127 (maximum)
FOOT CONTROLLER 2	127 (maximum)
FOOT SWITCH	0 (off)
ASSIGN 1	0 (center)
ASSIGN 2	0 (center)
RIBBON CONTROLLER	0 (center)
ASSIGNABLE FUNCTION 1	0 (off)
ASSIGNABLE FUNCTION 2	0 (off)
SUSTAIN SWITCH	0 (off)
SOSTENUTO SWITCH	0 (off)
RPN	Not assigned; No change

Doesn't reset the following data:

PROGRAM CHANGE, BANK SELECT MSB/LSB, VOLUME, PAN, HARMONIC CONTENT, SUSTAIN LEVEL, RELEASE TIME, ATTACK TIME, DECAY TIME, BRIGHTNESS, EFFECT SEND LEVEL 1, EFFECT SEND LEVEL 3, PORTAMENTO SWITCH, PITCH BEND SENSITIVITY, FINE TUNING, COARSE TUNING

(3-2-3) ALL NOTE OFF (CONTROL NUMBER = 7BH, DATA VALUE = 0)

All the notes currently set to on in certain channel(s) are muted when receiving this message. However, if Sustain or Sostenuto is on, notes will continue sounding until these are turned off.

(3-2-4) OMNI MODE OFF (CONTROL NUMBER = 7CH, DATA VALUE = 0)

Performs the same function as when receiving ALL NOTES OFF.
Sets VOICE RECEIVE CHANNEL to "OMNI OFF," channel 1.

(3-2-5) OMNI MODE ON (CONTROL NUMBER = 7DH, DATA VALUE = 0)

Performs the same function as when receiving ALL NOTES OFF.
Sets VOICE RECEIVE CHANNEL to "OMNI ON."

(3-2-6) MONO (CONTROL NUMBER = 7EH, DATA VALUE = 0..16)

Performs the same function as when receiving ALL SOUNDS OFF. If the 3rd byte (mono) is within 0 through 16, the channel will be Mode 4 (m = 1).
In the Voice mode, the mode can be Mode 2 (m = 1) according to VOICE RECEIVE CHANNEL.

(3-2-7) POLY (CONTROL NUMBER = 7FH, DATA VALUE = 0)

Performs the same function as when receiving ALL SOUNDS OFF. The channel will be Mode 3.
In the Voice mode, the mode can be Mode 1 according to VOICE RECEIVE CHANNEL.

(3-3) REGISTERED PARAMETER NUMBER

STATUS	1011nnnn (BnH)	n = 0 - 15 CHANNEL NUMBER
LSB	01100100 (64H)	
RPN LSB	0ppppppp	p = RPN LSB (Refer to the table as shown below.)
MSB	01100101 (65H)	
RPN MSB	0qggggggg	q = RPN MSB (Refer to the table as shown below.)
DATA ENTRY MSB	00000110 (06H)	
DATA VALUE	0mmmmmmm	m = Data Value
DATA ENTRY LSB	00100110 (26H)	
DATA VALUE	01111111	l = Data Value

First, designate the parameter using RPN MSB/LSB numbers. Then, set its value with data entry MSB/LSB.

RPN	D. ENTRY	
LSB MSB MSB LSB	PARAMETER NAME	DATA RANGE
00H 00H mmH ---	PITCH BEND SENSITIVITY	00H - 18H (0 - 24 semitones)
01H 00H mmH 11H	MASTER FINE TUNE	{mmH, 11H} = {00H, 00H} - {40H, 00H} - {7FH, 7FH} (-8192*100/8192) - 0 - (+8191*100/8192)
02H 00H mmH ---	MASTER COARSE TUNE	28H - 40H - 58H (-24 - 0 - +24 semitones)
7FH 7FH --- ---	RPN RESET	

RPN numbers will be left not designated.
The internal values are not affected.

(3-4) NON-REGISTERED PARAMETER NUMBER

There are no applicable parameters.

(3-5) SYSTEM REAL TIME MESSAGES**(3-5-1) ACTIVE SENSING**

STATUS	11111110 (FEH)
--------	----------------

Transmitted at every 200 msec.

Once this code is received, the instrument starts sensing. When no status nor data is received for over approximately 350 ms, MIDI receiving buffer will be cleared, and the sounds currently played and the Sustain Switch are forcibly turned off. Also, the values of the Controllers are reset to the default settings.

(3-6) SYSTEM EXCLUSIVE MESSAGE**(3-6-1) UNIVERSAL NON REALTIME MESSAGE****(3-6-1-1) GENERAL MIDI MODE ON**

F0H 7EH 7FH 09H 01H F7H

The internal tone generator block will receive this message when the instrument is in the Song/Pattern mode.

(3-6-1-2) IDENTITY REQUEST (Receive only)

F0H 7EH 0nH 06H 01H F7H

("n" = Device No. However, this instrument receives under "omni.")

(3-6-1-3) IDENTITY REPLY (Transmit only)

F0H 7EH 7FH 06H 02H 43H 00H 41H ddH ddH 00H 00H 00H 7FH F7H

dd; Device Number Code

MOX6: 44 06
MOX8: 45 06

(3-6-2) UNIVERSAL REALTIME MESSAGE**(3-6-2-1) MIDI MASTER VOLUME**

F0H 7FH 7FH 04H 01H 11H mmH F7H

Sets the MASTER VOLUME value.

The value "mm" is used to set the master volume (the value "ll" should be ignored).

(3-6-3) PARAMETER CHANGE**(3-6-3-1) NATIVE PARAMETER CHANGE, MODE CHANGE**

11110000	F0	Exclusive Status
01000011	43	YAMAHA ID
0001nnnn	1n	Device Number
01111111	7F	Model ID
00000000	14	Model ID
0aaaaaaaa	aaaaaaaa	Address High
0aaaaaaaa	aaaaaaaa	Address Mid
0aaaaaaaa	aaaaaaaa	Address Low
0	0	Data
11110111	F7	End of Exclusive

For parameters with data size of 2 or more, the appropriate number of data bytes will be transmitted. See the following MIDI Data Table for Address and Byte Count.

(3-6-4) BULK DUMP

11110000	F0	Exclusive Status
01000011	43	YAMAHA ID
0000nnnn	0n	Device Number
01111111	7F	Model ID
00000000	14	Model ID
0bbbbbbb	bbbbbbb	Byte Count
0bbbbbbb	bbbbbbb	Byte Count
0aaaaaaaa	aaaaaaaa	Address High
0aaaaaaaa	aaaaaaaa	Address Mid
0aaaaaaaa	aaaaaaaa	Address Low
0	0	Data
0ccccccc	ccccccc	Check-sum
11110111	F7	End of Exclusive

See the following BULK DUMP Table for Address and Byte Count.

The Check sum is the value that results in a value of 0 for the lower 7 bits when the Byte Count, Start Address, Data and Check sum itself are added.

(3-6-5) DUMP REQUEST

11110000	F0	Exclusive Status
01000011	43	YAMAHA ID
0010nnnn	2n	Device Number
01111111	7F	Model ID
00000000	14	Model ID
0aaaaaaaa	aaaaaaaa	Address High
0aaaaaaaa	aaaaaaaa	Address Mid
0aaaaaaaa	aaaaaaaa	Address Low
11110111	F7	End of Exclusive

See the following DUMP REQUEST Table for Address and Byte Count.

(3-6-6) PARAMETER REQUEST

11110000	F0	Exclusive Status
01000011	43	YAMAHA ID
0011nnnn	3n	Device Number
01111111	7F	Model ID
00000000	14	Model ID
0aaaaaaaa	aaaaaaaa	Address High
0aaaaaaaa	aaaaaaaa	Address Mid
0aaaaaaaa	aaaaaaaa	Address Low
11110111	F7	End of Exclusive

See the following MIDI Data Table for Address.

(4) SYSTEM OVERVIEW (Keyboard, Sequencer and Tone Generator)

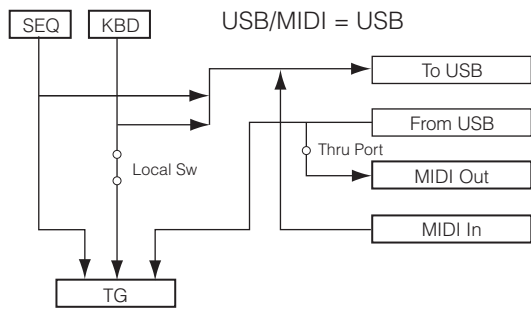
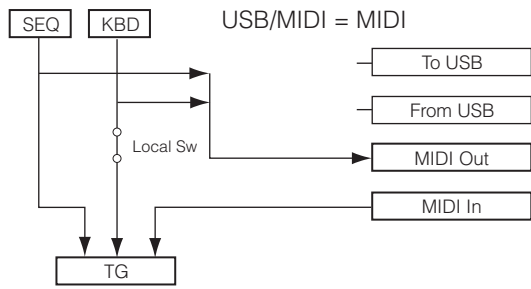

Although three types of note on/note off data, received via MIDI, played by the internal sequencer and played on the keyboard will be distinguished, the other controllers (channel messages) equally affect the entire notes.

ALL SOUND OFF clears all the sounds in the specific channel(s) played by both the keyboard and the data via MIDI.
 ALL NOTES OFF received via MIDI clears the sounds in the specific channel(s) played via MIDI.

MIDI Data Table

Bank Select

Available Bank Select/Program Change

MSB (HEX)	LSB (HEX)	Program No.	Type	Memory	Description		
0	00	0 - 00	Normal Voice	GM Voice			
127	7F	0	Drum Voice	GM Drum			
63	3F	0 - 127	Normal Voice	Preset 1			
		1 - 01		Preset 2			
		2 - 02		Preset 3			
		3 - 03		Preset 4			
		4 - 04		Preset 5			
		5 - 05		Preset 6			
		6 - 06		Preset 7			
		7 - 07		Preset 8			
		8 - 08		User 1			
		9 - 09		User 2			
		10 - 0A		User 3			
		32 - 20		0 - 63	Drum Voice	Preset	
		40 - 28		0 - 31	Mixing Voice	User	Can be selected in the Song/Pattern mode.
		60 - 3C		0 - 15		User	
63	3F	64 - 40	Performance	User 1			
		65 - 41		User 2			

When only the Program Change is received after entering any of the mode, the corresponding voice in the currently selected Type/Memory is called up.

The Master number and the Performance/Song/Pattern/Voice mode can be changed only via the Parameter Change.

The Song/Pattern can be changed only via the Song Select (Song: F3, 00 - F3, 3F / Pattern: F3, 00 - F3, 3F).

In the Performance mode, the Part Voice cannot be changed via the Program Change.

Parameter Base Address

Parameter Block	Top Address			Settings	
	High	Mid	Low		
	SYSTEM	00	00		00
	00	03	00	Insertion A for Voice A/D	
	00	04	00	Insertion B for Voice A/D	
	00	05	00	Sequencer Setup	
	00	06	00	Remote	
	00	20	00	Master EQ for Voice	
	00	21	00	Master Effect for Voice	
	00	4n	00	Audio Part (A/D)	
	00	5n	00	Quick Setup	
	00	6n	00	Quick Setup Config Audio	
	00	7n	00	Quick Setup Config MIDI	
MODE CHANGE	0A	00	00	Mode Change	
PART SET CONTROL for MIX VOICE	0D	00	00	Part Set Control for Mix Voice	
BULK CONTROL	0E	00	00	Header	
	0F	00	00	Footer	
MULTIPLE BULK CONTROL	10	00	00	Header	
	11	00	00	Footer	
MASTER KEYBOARD	33	00	00	Common	
	32	nn	00	Zone 1 - 4 (nn: 00 - 03)	
PERFORMANCE COMMON	30	00	00	Common	
	30	01	00	Reverb	
	30	02	00	Chorus	
	30	03	00	Insertion A for A/D	
	30	04	00	Insertion B for A/D	
	30	10	00	Master EQ	
	30	11	00	Master Effect	
	30	30	00	Arpeggio Common	
	PERFORMANCE PART	31	pp	00	Part 1 - 4 (pp: 00 - 03)
		34	pp	00	Arpeggio Part 1 - 4 (pp: 00 - 03)
35		4n	00	Audio Part (A/D)	
SONG/PATTERN COMMON	36	00	00	Common	
	36	01	00	Reverb	
	36	02	00	Chorus	
	36	03	00	Insertion A for A/D	
	36	04	00	Insertion B for A/D	
	36	10	00	Master EQ	
	36	11	00	Master Effect	
	36	30	00	Arpeggio Common	
	SONG/PATTERN PART	37	pp	00	Part 1 - 16 (pp: 00 - 0F)
		38	pp	00	Arpeggio Part 1 - 16 (pp: 00 - 0F)
39		4n	00	Audio Part (A/D)	
NORMAL VOICE COMMON	40	00	00	Common	
	40	01	00	Reverb	
	40	02	00	Chorus	
	40	03	00	Insertion A	
	40	04	00	Insertion B	
	40	05	00	Insertion L	
	40	06	00	Controller+LFO	
	40	30	00	Arpeggio	
	NORMAL VOICE ELEMENT GROUP 1	41	ee	00	Element Group 1 (ee: 00 - 07)
	NORMAL VOICE ELEMENT GROUP 2	42	ee	00	Element Group 2 (ee: 00 - 07)
DRUM COMMON	46	00	00	Common	
	46	01	00	Reverb	
	46	02	00	Chorus	
	46	03	00	Insertion A	
	46	04	00	Insertion B	
	46	05	00	Insertion L	
	46	08	00	Controller	
	46	30	00	Arpeggio	
DRUM ELEMENT GROUP	47	ee	00	Element Group (ee: 0 - 72)	

Bulk Dump Block

"Top Address" indicates the top address of each block designated by bulk dump operation.
 "Byte Count" indicates the data size contained in each block designated by bulk dump operation.

The Block from the Bulk Header to the Bulk Footer of the Performance and Voice can be received regardless their order. They can be received even if all of them are not transmitted. They cannot be received if the irrelevant Block is included.

To execute 1 Performance/1 Voice bulk dump request, designate its corresponding Bulk Header address.

For the information about "mm" and "nn" shown in the following list, refer to MIDI PARAMETER CHANGE TABLE (BULK CONTROL) below.

Parameter Block	Settings	Byte Count		Top Address				
		Dec	Hex	High	Mid	Low		
SYSTEM	System	68	44	00	00	00		
	Insertion A for Voice A/D	36	24	00	03	00		
	Insertion B for Voice A/D	36	24	00	04	00		
	Sequencer Setup	22	16	00	05	00		
	Remote	6	06	00	06	00		
	Master EQ for Voice	20	14	00	20	00		
	Master Effect for Voice	38	26	00	21	00		
	AUDIO IN PART	Audio Part (A/D)	8	08	00	40	00	
	QUICK SETUP	Setup 1	10	0A	00	50	00	
		:						
		Setup 6				55		
	QUICK SETUP CONFIG AUDIO	Config 1	16	10	00	60	00	
		:						
		Config 6				65		
QUICK SETUP CONFIG MIDI	Config 1	16	10	00	70	00		
	:							
	Config 6				75			
MASTER KEYBOARD	Bulk Header	0	00	0E	mm	nn		
	COMMON	Common	32	20	33	00	00	
	ZONE	Zone 1	16	10	32	00	00	
		:						
		Zone 4				03		
		Bulk Footer	0	00	0F	mm	nn	
	PERFORMANCE	Bulk Header	0	00	0E	mm	nn	
		COMMON	Common	80	50	30	00	00
			Reverb	38	26	30	01	00
			Chorus	40	28	30	02	00
Insertion A for A/D			36	24	30	03	00	
Insertion B for A/D			36	24	30	04	00	
Master EQ			20	14	30	10	00	
Master Effect			38	26	30	11	00	
Arpeggio Common			14	0E	30	30	00	
PART		Part 1	62	3E	31	00	00	
		:						
		Part 4				03		
		Arpeggio Part 1	72	48	34	00	00	
		:						
		Arpeggio Part 4				03		
AUDIO IN PART		Audio Part (A/D)	8	08	35	40	00	
		Bulk Footer	0	00	0F	mm	nn	
SONG/PATTERN		Bulk Header	0	00	0E	mm	nn	
		COMMON	Common	80	50	36	00	00
			Reverb	38	26	36	01	00
	Chorus		40	28	36	02	00	
	Insertion A for A/D		36	24	36	03	00	
	Insertion B for A/D		36	24	36	04	00	
	Master EQ		20	14	36	10	00	
	Master Effect		38	26	36	11	00	
	Arpeggio Common		14	0E	36	30	00	
	PART	Part 1	62	3E	37	00	00	
		:						
		Part 16				0F		
		Arpeggio Part 1	72	48	38	00	00	
		:						
		Arpeggio Part 16				0F		
	AUDIO IN PART	Audio Part (A/D)	8	08	39	40	00	
		Bulk Footer	0	00	0F	mm	nn	

Parameter Block	Settings	Byte Count		Top Address			
		Dec	Hex	High	Mid	Low	
VOICE (NORMAL)	Bulk Header	0	00	0E	mm	nn	
	COMMON	Common	80	50	40	00	00
		Reverb	38	26	40	01	00
		Chorus	40	28	40	02	00
		Insertion A	36	24	40	03	00
		Insertion B	36	24	40	04	00
		Insertion L	68	44	40	05	00
		Controller+LFO	60	3C	40	06	00
		Arpeggio	86	56	40	30	00
	ELEMENT	Osc+Amp+Pit Element 1	88	58	41	00	00
		:					
		Osc+Amp+Pit Element 8				07	
		Flt+EQ+LFO Element 1	74	4A	42	00	00
		:					
	Flt+EQ+LFO Element 8				07		
	Bulk Footer	0	00	0F	mm	nn	
VOICE (DRUM)	Bulk Header	0	00	0E	mm	nn	
	COMMON	Common	72	48	46	00	00
		Reverb	38	26	46	01	00
		Chorus	40	28	46	02	00
		Insertion A	36	24	46	03	00
		Insertion B	36	24	46	04	00
		Insertion L	68	44	46	05	00
		Controller	24	18	46	08	00
		Arpeggio	86	56	46	30	00
	KEY	Key C0	46	2E	47	00	00
		:					
		Key C6				48	
		Bulk Footer	0	00	0F	mm	nn

MIDI PARAMETER CHANGE TABLE (MODE CHANGE)

Address			Size	Data Range (HEX)	Parameter Name	Settings	Default (HEX)	Notes
High	Mid	Low						
0A	00	00	1	00 – 7F	Master Number Select	0 – 127		
		01	1	00 – 06	Mode Change	0: Voice, 1: Performance, 2: Pattern (Multi), 3: Song (Multi), 4: Master		
		03	1		reserved			

TOTAL SIZE = 4 04 (HEX)

MIDI PARAMETER CHANGE TABLE (PART SET CONTROL for MIX VOICE)

Address			Size	Data Range (HEX)	Parameter Name	Settings	Default (HEX)	Notes
High	Mid	Low						
0D	00	00	1	00 – 0F	Part Set Control for Mix Voice	0 – 15		

TOTAL SIZE = 1 01 (HEX)

MIDI PARAMETER CHANGE TABLE (BULK CONTROL)

Address			Size	Data Range (HEX)	Parameter Name	Settings	Default (HEX)	Notes
High	Mid	Low						
0E	00	nn	1	-	Bulk Header	Normal Voice PRE 1 (nn = 0 – 127)	-	
	01	nn	1	-		Normal Voice PRE 2 (nn = 0 – 127)	-	
	02	nn	1	-		Normal Voice PRE 3 (nn = 0 – 127)	-	
	03	nn	1	-		Normal Voice PRE 4 (nn = 0 – 127)	-	
	04	nn	1	-		Normal Voice PRE 5 (nn = 0 – 127)	-	
	05	nn	1	-		Normal Voice PRE 6 (nn = 0 – 127)	-	
	06	nn	1	-		Normal Voice PRE 7 (nn = 0 – 127)	-	
	07	nn	1	-		Normal Voice PRE 8 (nn = 0 – 127)	-	
	09	nn	1	-		Normal Voice GM (nn = 0 – 127)	-	
	0A	nn	1	-		Normal Voice USER 1 (nn = 0 – 127)	-	
	0B	nn	1	-		Normal Voice USER 2 (nn = 0 – 127)	-	
	0C	nn	1	-		Normal Voice USER 3 (nn = 0 – 127)	-	
	0F	nn	1	-		Normal Voice Edit Buffer (nn = 0)	-	
	20	nn	1	-		Drum Voice PRE (nn = 0 – 63)	-	
	21	nn	1	-		Drum Voice GM (nn = 0)	-	
	28	nn	1	-		Drum Voice USER (nn = 0 – 31)	-	
	29	nn	1	-		reserved	-	
	2F	nn	1	-		Drum Voice Edit Buffer (nn = 0)	-	
	30	nn	1	-		Mixing Part Voice Edit Buffer (nn = 0 – 15) nn: part	-	
	31	nn	1	-		Mixing Voice (Current Song/Pattern) (nn = 0 – 15) nn: Voice Number	-	
	40	nn	1	-		Performance USER 1 (nn = 0 – 127)	-	
	41	nn	1	-		Performance USER 2 (nn = 0 – 127)	-	
	4F	nn	1	-		Performance Edit Buffer (nn = 0)	-	
	5F	nn	1	-		Song/Pattern Edit Buffer (nn = 0)	-	
	70	nn	1	-		Master USER (nn = 0 – 127)	-	
	7F	nn	1	-		Master Edit Buffer (nn = 0)	-	
0F	00	nn	1	-	Bulk Footer	Normal Voice PRE 1 (nn = 0 – 127)	-	
	01	nn	1	-		Normal Voice PRE 2 (nn = 0 – 127)	-	
	02	nn	1	-		Normal Voice PRE 3 (nn = 0 – 127)	-	
	03	nn	1	-		Normal Voice PRE 4 (nn = 0 – 127)	-	
	04	nn	1	-		Normal Voice PRE 5 (nn = 0 – 127)	-	
	05	nn	1	-		Normal Voice PRE 6 (nn = 0 – 127)	-	
	06	nn	1	-		Normal Voice PRE 7 (nn = 0 – 127)	-	
	07	nn	1	-		Normal Voice PRE 8 (nn = 0 – 127)	-	
	09	nn	1	-		Normal Voice GM (nn = 0 – 127)	-	
	0A	nn	1	-		Normal Voice USER 1 (nn = 0 – 127)	-	
	0B	nn	1	-		Normal Voice USER 2 (nn = 0 – 127)	-	
	0C	nn	1	-		Normal Voice USER 3 (nn = 0 – 127)	-	
	0F	nn	1	-		Normal Voice Edit Buffer (nn = 0)	-	
	20	nn	1	-		Drum Voice PRE (nn = 0 – 63)	-	
	21	nn	1	-		Drum Voice GM (nn = 0)	-	
	28	nn	1	-		Drum Voice USER (nn = 0 – 31)	-	
	29	nn	1	-		reserved	-	
	2F	nn	1	-		Drum Voice Edit Buffer (nn = 0)	-	
	30	nn	1	-		Mixing Part Voice Edit Buffer (nn = 0 – 15) nn: part	-	
	31	nn	1	-		Mixing Voice (Current Song/Pattern) (nn = 0 – 15) nn: Voice Number	-	
	40	nn	1	-		Performance USER 1 (nn = 0 – 127)	-	
	41	nn	1	-		Performance USER 2 (nn = 0 – 127)	-	
	4F	nn	1	-		Performance Edit Buffer (nn = 0)	-	
	5F	nn	1	-		Song/Pattern Edit Buffer (nn = 0)	-	
	70	nn	1	-		Master USER (nn = 0 – 127)	-	
	7F	nn	1	-		Master Edit Buffer (nn = 0)	-	

MIDI PARAMETER CHANGE TABLE (SYSTEM)

Address			Size	Data Range (HEX)	Parameter Name	Settings	Default (HEX)	Notes
High	Mid	Low						
00	00	00	1	00 – 7F	Master Volume	0 – 127	7F	MIDI Master Volume
		01	1	28 – 58	Master Note Shift	-24 – +24 [semitones]	40	
		02	4	00 – 00 00 – 07 00 – 0F 00 – 0F	Master Tune	-102.4 – +102.3 [cent] 1st bit3-0 → bit15-12 2nd bit3-0 → bit11-8 3rd bit3-0 → bit7-4 4th bit3-0 → bit3-0	00 04 00 00 (04 00)	MIDI Master Tuning
		06	1	00 – 01	Controller Reset	hold, reset	01	
		07	1	35 – 4B	Master Transpose	-11 – +11 (semitones)	40	
		08	1	3D – 43	Master Octave Shift	-3 – +3	40	
		09	1	00 – 01	Local Switch	off, on	01	
		0A	1	00 – 10, 7F	Basic Receive Channel	1 – 16, omni, off	00	
		0B	1	00 – 0F, 7F	Keyboard Transmit Channel	1 – 16, off	00	
		0C	1	00 – 04	Knob Speed Table	Table 1, 2, 3, 4, 5	02	
		0D	1	00 – 01	Stereo L&R Output Gain	00:0dB, 01:+6dB	01	
		0E	1	00 – 02	Audio Connection Mode	VST Mode, 2 Stereo Rec Mode, 1 Stereo Rec Mode	01	
		0F	1	00 – 01	Direct Monitor Switch A/D In/Part	off, on	01	For the audio signal which is output via "USB 1."
		10	1	00 – 01	Direct Monitor Switch Part	off, on	01	for the audio signal which is output via "USB 2."
		11	1	00 – 04	Keyboard Velocity Curve	normal, soft, hard, wide, fixed	00	
		12	1	01 – 7F	Keyboard Fixed Velocity	1 – 127	40	
		13	1	00 – 01	Rec Arp	off, on	00	
		14	1	00 – 01	Receive/Transmit Bank Select	off, on	01	
		15	1	00 – 01	Receive/Transmit Program Change	off, on	01	
		16	1		reserved			
		17	1		reserved			
		18	1	00 – 01	MIDI In/Out	MIDI, USB	01	
		19	1	00 – 03	System Effect On/Off Button	bit0: Reverb, bit1: Chorus	03	
		1A	1		reserved			
		1B	1	00 – 01	Knob Function Display Switch	off, on	01	
		1C	1	00 – 07	Knob Display Time	off, 1, 1.5, 2, 3, 4, 5, keep	02	
		1D	1		reserved			
		1E	1	00 – 04	Power on Mode	performance, voice (USR1), voice (PRE1), voice (GM), master	04	
		1F	1	00 – 12	Bulk Dump Interval	0, 10, 20, 30, 40, 50, 60, 70, 80, 90, 100, 200, 300, 400, 500, 600, 700, 800, 900ms	00	
		20	1		reserved			
		21	1	00 – 01	LCD Mode	normal, reverse	00	
		22	1	00 – 0F	LCD Contrast	1 – 16	07	
		23	1	01 – 02	A/D Input Insertion Connect Type	ins A>B, ins B>A	01	For the Voice Mode
		24	1	00 – 01	A/D Input Gain	mic, line	01	
		25	1	00 – 01	USB 1/2 Output Gain	00:0dB, 01:+6dB	01	
		26	1	00 – 01	USB 3/4 Output Gain	00:0dB, 01:+6dB	01	
		27	1		reserved			
		28	1	00 – 01	Voice ARP MIDI Out Switch	off, on	00	For the Voice Mode
		29	1	00 – 0F	Voice ARP Transmit Channel	1 – 16	00	For the Voice Mode
		2A	1	00 – 5F	RB Control Number	off, 1 – 95	16	
		2B	1	00 – 64	Foot Switch Assign	off, 1 – 95, arp sw, play/stop, PC inc, PC dec, octave reset	60	
		2C	1	00 – 5F	Control Number Assign 1	off, 1 – 95	10	
		2D	1	00 – 5F	Control Number Assign 2	off, 1 – 95	11	
		2E	1	00 – 5F	Control Number Breath Controller	off, 1 – 95	02	
		2F	1	00 – 5F	Control Number Foot Controller 1	off, 1 – 95	0B	
		30	1	00 – 5F	Control Number Foot Controller 2	off, 1 – 95	04	
		31	1	00 – 5F	Control Number Assignable Function 1	off, 1 – 95	56	
		32	1	00 – 5F	Control Number Assignable Function 2	off, 1 – 95	57	
		33	1	00 – 02	Foot Switch Sustain Pedal Select	FC3 (Half On), FC3 (Half Off), FC4/5	00	
		34	1		reserved			

Address			Size	Data Range (HEX)	Parameter Name	Settings	Default (HEX)	Notes
High	Mid	Low						
		35	1	00 - 0F	Performance Creator Layer Voice Bank	0 - 7: PRE1, PRE2, PRE3, PRE4, PRE5, PRE6, PRE7, PRE8 8 - 10: USR1, USR2, USR3 12: PDR 13: UDR 14: GM 15: GMDR	03	PRE4 C13 PWM Simple
		36	1		reserved			
		37	1	00 - 7F	Performance Creator Layer Voice Program	1 - 128	2C	
		38	1		reserved			
		39	1	00 - 0F	Performance Creator Split Voice Bank	1 - 7: PRE1, PRE2, PRE3, PRE4, PRE5, PRE6, PRE7, PRE8 8 - 10: USR1, USR2, USR3 12: PDR 13: UDR 14: GM 15: GMDR	02	PRE3 D10 DarkBass
		3A	1		reserved			
		3B	1	00 - 7F	Performance Creator Split Voice Program	1 - 128	39	
		3C	1	00 - 02	Performance Creator Split Lower/Upper	both, lower, upper	01	
		3D	1		reserved			
		3E	1	00 - 0F	Performance Creator Drum Voice Bank	0 - 7: PRE1, PRE2, PRE3, PRE4, PRE5, PRE6, PRE7, PRE8 8 - 10: USR1, USR2, USR3 12: PDR 13: UDR 14: GM 15: GMDR	0C	PDR A01 Power Standard Kit 1
		3F	1		reserved			
		40	1	00 - 7F	Performance Creator Drum Voice Program	1 - 128	00	
		41	1	00 - 01	Performance Creator Confirm Message	off, on	01	
		42	1		reserved			
		43	1		reserved			

TOTAL SIZE 68 44 (HEX)

Address			Size	Data Range (HEX)	Parameter Name	Settings	Default (HEX)	Notes
High	Mid	Low						
00	03	00	2	00 - 7F 00 - 7F	Insertion A Type	Refer to the "Effect Type List."	00 00	For A/D Part
		02	1	00 - 7F	Preset Number		00	
		03	1		reserved			
		04	2	00 - 7F 00 - 7F	Insertion A Parameter 1	Refer to the "Effect Parameter List."	00 00	
		06	2	00 - 7F 00 - 7F	Insertion A Parameter 2	:	00 00	
		08	2	00 - 7F 00 - 7F	Insertion A Parameter 3	:	00 00	
		0A	2	00 - 7F 00 - 7F	Insertion A Parameter 4	:	00 00	
		0C	2	00 - 7F 00 - 7F	Insertion A Parameter 5	:	00 00	
		0E	2	00 - 7F 00 - 7F	Insertion A Parameter 6	:	00 00	
		10	2	00 - 7F 00 - 7F	Insertion A Parameter 7	:	00 00	
		12	2	00 - 7F 00 - 7F	Insertion A Parameter 8	:	00 00	
		14	2	00 - 7F 00 - 7F	Insertion A Parameter 9	:	00 00	
		16	2	00 - 7F 00 - 7F	Insertion A Parameter 10	:	00 00	
		18	2	00 - 7F 00 - 7F	Insertion A Parameter 11	:	00 00	
		1A	2	00 - 7F 00 - 7F	Insertion A Parameter 12	:	00 00	
		1C	2	00 - 7F 00 - 7F	Insertion A Parameter 13	:	00 00	
		1E	2	00 - 7F 00 - 7F	Insertion A Parameter 14	:	00 00	
		20	2	00 - 7F 00 - 7F	Insertion A Parameter 15	:	00 00	
		22	2	00 - 7F 00 - 7F	Insertion A Parameter 16	:	00 00	

TOTAL SIZE = 36 24 (HEX)

Address			Size	Data Range (HEX)	Parameter Name	Settings	Default (HEX)	Notes
High	Mid	Low						
00	04	00	2	00 - 7F 00 - 7F	Insertion B Type	Refer to the "Effect Type List."	00 00	For A/D Part
		02	1	00 - 7F	Preset Number		00	
		03	1		reserved			
		04	2	00 - 7F 00 - 7F	Insertion B Parameter 1	Refer to the "Effect Parameter List."	00 00	
		06	2	00 - 7F 00 - 7F	Insertion B Parameter 2	:	00 00	
		08	2	00 - 7F 00 - 7F	Insertion B Parameter 3	:	00 00	
		0A	2	00 - 7F 00 - 7F	Insertion B Parameter 4	:	00 00	
		0C	2	00 - 7F 00 - 7F	Insertion B Parameter 5	:	00 00	
		0E	2	00 - 7F 00 - 7F	Insertion B Parameter 6	:	00 00	
		10	2	00 - 7F 00 - 7F	Insertion B Parameter 7	:	00 00	
		12	2	00 - 7F 00 - 7F	Insertion B Parameter 8	:	00 00	
		14	2	00 - 7F 00 - 7F	Insertion B Parameter 9	:	00 00	
		16	2	00 - 7F 00 - 7F	Insertion B Parameter 10	:	00 00	
		18	2	00 - 7F 00 - 7F	Insertion B Parameter 11	:	00 00	
		1A	2	00 - 7F 00 - 7F	Insertion B Parameter 12	:	00 00	
		1C	2	00 - 7F 00 - 7F	Insertion B Parameter 13	:	00 00	
		1E	2	00 - 7F 00 - 7F	Insertion B Parameter 14	:	00 00	
		20	2	00 - 7F 00 - 7F	Insertion B Parameter 15	:	00 00	
		22	2	00 - 7F 00 - 7F	Insertion B Parameter 16	:	00 00	

TOTAL SIZE = 36 24 (HEX)

Address			Size	Data Range (HEX)	Parameter Name	Settings	Default (HEX)	Notes
High	Mid	Low						
00	05	00	1	00 - 03	Click Mode	off, rec, rec/play, all	01	For SEQ
		01	1	01 - 04	Click Beat	16, 08, 04, 02, 01	02	For SEQ
		02	1	00 - 7F	Click Volume	0 - 127	64	For SEQ
		03	1	00 - 09	Click Type	1 - 10	00	For SEQ
		04	1	00 - 08	Recording Count	off, 1...8 meas	01	For SEQ
		05	1		reserved			
		06	1	00 - 04	Pattern Quantize	1, 1/2, 1/4, 1/8, 1/16	00	For SEQ
		07	1	00 - 01	Pattern Tempo Hold Switch	off, on	00	For SEQ
		08	1	00 - 03	Song Event Chase	off, pc, pc+pb+ctrl, all	00	For SEQ
		09	1		reserved			
		0A	1	00 - 01	Load Mix Switch	off, on	01	For SEQ
		0B	1	00 - 03	MIDI Sync	internal, external, auto, MTC	02	For SEQ
		0C	1	00 - 01	MIDI Clock Out	off, on	01	For SEQ
		0D	1	00 - 03	Sequencer Control	off, in, out, in/out	03	For SEQ
		0E	1	00 - 17	MTC start offset	1st: Hour 2nd: Minute 3rd: Second 4th: Frame	00 00 00 00	For SEQ
		0F	1	00 - 3B				
		10	1	00 - 3B				
		11	1	00 - 1D				
		12	2	00 - 01 00 - 7F	MIDI In Filter	1st bit6-1: reserved 1st bit0: off, on reserved 2nd bit6: off, on Exclusive 2nd bit5: off, on Channel After 2nd bit4: off, on Poly After 2nd bit3: off, on Program Change 2nd bit2: off, on Control Change 2nd bit1: off, on Pitch Bend 2nd bit0: off, on Note	01 7F	For SEQ
		14	2	00 - 01 00 - 7F	MIDI Out Filter	same as MIDI In Filter	01 6F	For SEQ

TOTAL SIZE = 22 16 (HEX)

Address			Size	Data Range (HEX)	Parameter Name	Settings	Default (HEX)	Notes
High	Mid	Low						
00	06	00	1	00 - 03	DAW Select	Cubase, LogicPro, Digital Performer, SONAR	00	
		01	1	00 - 02	Program Change Mode	remote, PC, remote+PC	00	This is available only when "DAW Select" is set to "Cubase."
		02	1		reserved			
		03	1		reserved			
		04	1		reserved			
		05	1		reserved			

TOTAL SIZE = 6 06 (HEX)

Address			Size	Data Range (HEX)	Parameter Name	Settings	Default (HEX)	Notes
High	Mid	Low						
00	20	00	1	34 - 4C	EQ Low Gain	-12 - +12 [dB]	40	For the Voice Mode
		01	1	04 - 28	EQ Low Frequency	32 - 2000 [Hz]	0C	When setting the EQ shape peaking type, the range is 63Hz - 2.0kHz.
		02	1	01 - 78	EQ Low Q	0.1 - 12.0	07	When setting the EQ shape shelving type, this is not available.
		03	1	00 - 01	EQ Low Shape	shelv, peak	00	
		04	1	34 - 4C	EQ Low-Mid Gain	-12 - +12 [dB]	40	
		05	1	0E - 36	EQ Low-Mid Frequency	100 - 10.0 [kHz]	14	
		06	1	01 - 78	EQ Low-Mid Q	0.1 - 12.0	07	
		07	1		reserved			
		08	1	34 - 4C	EQ Mid Gain	-12 - +12 [dB]	40	
		09	1	0E - 36	EQ Mid Frequency	100 - 10.0 [kHz]	1C	
		0A	1	01 - 78	EQ Mid Q	0.1 - 12.0	07	
		0B	1		reserved			
		0C	1	34 - 4C	EQ High-Mid Gain	-12 - +12 [dB]	40	
		0D	1	0E - 36	EQ High-Mid Frequency	100 - 10.0 [kHz]	2C	
		0E	1	01 - 78	EQ High-Mid Q	0.1 - 12.0	07	
		0F	1		reserved			
		10	1	34 - 4C	EQ High Gain	-12 - +12 [dB]	40	
		11	1	1C - 3A	EQ High Frequency	0.5 - 16.0 [kHz]	34	
		12	1	01 - 78	EQ High Q	0.1 - 12.0	07	When setting the EQ shape shelving type, this is not available.
		13	1	00 - 01	EQ High Shape	shelv, peak	00	

TOTAL SIZE = 20 14 (HEX)

Address			Size	Data Range (HEX)	Parameter Name	Settings	Default (HEX)	Notes
High	Mid	Low						
00	4n	00	1	00 - 03	Audio Input Mode	L mono, R mono, L+R mono, stereo	03	Audio In Part (A/D)
		01	1	00 - 7F	Audio Input Part Volume	0 - 127	64	
		02	1	01 - 7F	Audio Input Part Pan	L63 - C - R63	40	
		03	1	00 - 7F	Audio Input Part Reverb Send	0 - 127	0C	
		04	1	00 - 7F	Audio Input Part Chorus Send	0 - 127	00	
		05	1		reserved			
		06	1	00 - 7F	Audio Input Part Dry Level	0 - 127	7F	
		07	1		reserved			

TOTAL SIZE = 8 08 (HEX)
n = part number 00 - 00

Address			Size	Data Range (HEX)	Parameter Name	Settings	Default (HEX)	Notes
High	Mid	Low						
00	5n	00	1	00, 20 - 7E	Quick Setup Name 1	0, 32..126 (ASCII)	20	
		01	1	00, 20 - 7E	Quick Setup Name 2	0, 32..126 (ASCII)	20	
		02	1	00, 20 - 7E	Quick Setup Name 3	0, 32..126 (ASCII)	20	
		03	1	00, 20 - 7E	Quick Setup Name 4	0, 32..126 (ASCII)	20	
		04	1	00, 20 - 7E	Quick Setup Name 5	0, 32..126 (ASCII)	20	
		05	1	00, 20 - 7E	Quick Setup Name 6	0, 32..126 (ASCII)	20	
		06	1	00, 20 - 7E	Quick Setup Name 7	0, 32..126 (ASCII)	20	
		07	1	00, 20 - 7E	Quick Setup Name 8	0, 32..126 (ASCII)	20	
		08	1	00 - 06	Config Number Audio	---, config 1 - 6		
		09	1	00 - 06	Config Number MIDI	---, config 1 - 6		

TOTAL SIZE = 10 0A (HEX)
n = step number 00 - 05

Address			Size	Data Range (HEX)	Parameter Name	Settings	Default (HEX)	Notes
High	Mid	Low						
00	21	00	2	00 - 7F 00 - 7F	Master Effect Type	Refer to the "Effect Type List."	08 20	For the Voice Mode Multi Band Comp
		02	1	00 - 7F	Preset Number		00	Basic
		03	1		reserved			
		04	2	00 - 7F 00 - 7F	Master Effect Parameter 1	Refer to the "Effect Parameter List."		Init value for Multi Band Comp / Basic
		06	2	00 - 7F 00 - 7F	Master Effect Parameter 2	:		Init value for Multi Band Comp / Basic
		08	2	00 - 7F 00 - 7F	Master Effect Parameter 3	:		Init value for Multi Band Comp / Basic
		0A	2	00 - 7F 00 - 7F	Master Effect Parameter 4	:		Init value for Multi Band Comp / Basic
		0C	2	00 - 7F 00 - 7F	Master Effect Parameter 5	:		Init value for Multi Band Comp / Basic
		0E	2	00 - 7F 00 - 7F	Master Effect Parameter 6	:		Init value for Multi Band Comp / Basic
		10	2	00 - 7F 00 - 7F	Master Effect Parameter 7	:		Init value for Multi Band Comp / Basic
		12	2	00 - 7F 00 - 7F	Master Effect Parameter 8	:		Init value for Multi Band Comp / Basic
		14	2	00 - 7F 00 - 7F	Master Effect Parameter 9	:		Init value for Multi Band Comp / Basic
		16	2	00 - 7F 00 - 7F	Master Effect Parameter 10	:		Init value for Multi Band Comp / Basic
		18	2	00 - 7F 00 - 7F	Master Effect Parameter 11	:		Init value for Multi Band Comp / Basic
		1A	2	00 - 7F 00 - 7F	Master Effect Parameter 12	:		Init value for Multi Band Comp / Basic
		1C	2	00 - 7F 00 - 7F	Master Effect Parameter 13	:		Init value for Multi Band Comp / Basic
		1E	2	00 - 7F 00 - 7F	Master Effect Parameter 14	:		Init value for Multi Band Comp / Basic
		20	2	00 - 7F 00 - 7F	Master Effect Parameter 15	:		Init value for Multi Band Comp / Basic
		22	2	00 - 7F 00 - 7F	Master Effect Parameter 16	:		Init value for Multi Band Comp / Basic
		24	1	00 - 01	Master Effect Switch	off, on	00	
		25	1		reserved			

TOTAL SIZE = 38 26 (HEX)

Address			Size	Data Range (HEX)	Parameter Name	Settings	Default (HEX)	Notes
High	Mid	Low						
00	6n	00	1	00 - 02	Audio Connection Mode	VST Mode, 2 Stereo Rec Mode, 1 Stereo Rec Mode		
		01	1	00 - 01	Direct Monitor Switch A/D In/Part	off, on		For the audio signal which is output via "USB 1/2."
		02	1	00 - 01	Direct Monitor Switch Part	off, on		For the audio signal which is output via "USB 3/4."
		03	1		reserved			
		04	1		reserved			
		05	1		reserved			
		06	1		reserved			
		07	1		reserved			
		08	1		reserved			
		09	1		reserved			
		0A	1		reserved			
		0B	1		reserved			
		0C	1		reserved			
		0D	1		reserved			
		0E	1		reserved			
		0F	1		reserved			

TOTAL SIZE = 16 10 (HEX)
n = config number 00 - 05

Address			Size	Data Range (HEX)	Parameter Name	Settings	Default (HEX)	Notes
High	Mid	Low						
00	7n	00	1	00 - 01	Local Switch	off, on		
		01	1	00 - 03	Midi Sync	internal, external, auto, MTC		
		02	1	00 - 01	Midi Clock Out	off, on		
		03	1	00 - 01	Track Internal Switch	all off, all on		For SEQ
		04	1	00 - 01	Track External Switch	all off, all on		For SEQ
		05	1	00 - 01	ARP MIDI Out Switch	all off, all on		
		06	1	00 - 01	Keyboard Transmit Channel	1 - 16, off		
		07	1		reserved			
		08	1		reserved			
		09	1		reserved			
		0A	1		reserved			
		0B	1		reserved			
		0C	1		reserved			
		0D	1		reserved			
		0E	1		reserved			
		0F	1		reserved			

TOTAL SIZE = 16 10 (HEX)
n = config number 00 - 05

MIDI PARAMETER CHANGE TABLE (MASTER KEYBOARD)

Address			Size	Data Range (HEX)	Parameter Name	Settings	Default (HEX)	Notes
High	Mid	Low						
33	00	00	1	00, 20 - 7E	Master Name 1	32..126 (ASCII)	l	
		01	1	00, 20 - 7E	Master Name 2	32..126 (ASCII)	n	
		02	1	00, 20 - 7E	Master Name 3	32..126 (ASCII)	i	
		03	1	00, 20 - 7E	Master Name 4	32..126 (ASCII)	t	
		04	1	00, 20 - 7E	Master Name 5	32..126 (ASCII)	j	
		05	1	00, 20 - 7E	Master Name 6	32..126 (ASCII)	a	
		06	1	00, 20 - 7E	Master Name 7	32..126 (ASCII)	l	
		07	1	00, 20 - 7E	Master Name 8	32..126 (ASCII)	i	
		08	1	00, 20 - 7E	Master Name 9	32..126 (ASCII)	z	
		09	1	00, 20 - 7E	Master Name 10	32..126 (ASCII)	e	
		0A	1	00, 20 - 7E	Master Name 11	32..126 (ASCII)	d	
		0B	1	00, 20 - 7E	Master Name 12	32..126 (ASCII)		
		0C	1	00, 20 - 7E	Master Name 13	32..126 (ASCII)	M	
		0D	1	00, 20 - 7E	Master Name 14	32..126 (ASCII)	a	
		0E	1	00, 20 - 7E	Master Name 15	32..126 (ASCII)	s	
		0F	1	00, 20 - 7E	Master Name 16	32..126 (ASCII)	t	
		10	1	00, 20 - 7E	Master Name 17	32..126 (ASCII)	e	
		11	1	00, 20 - 7E	Master Name 18	32..126 (ASCII)	r	
		12	1	00, 20 - 7E	Master Name 19	32..126 (ASCII)		
		13	1	00, 20 - 7E	Master Name 20	32..126 (ASCII)		
		14	1		reserved			
		15	1		reserved			
		16	1		reserved			
		17	1		reserved			
		18	1		reserved			
		19	1	00 - 03	Mode Change	0=Voice, 1=Performance, 2=Pattern, 3=Song	00	
		1A	1	00 - 7F	Bank MSB for Voice/Perf Mode	0..127	3F	
		1B	1	00 - 7F	Bank LSB for Voice/Perf Mode	0..127	00	
		1C	1	00 - 7F	Program Number	1..128	00	
		1D	1	00 - 01	Zone on/off	off, on	00	
		1E	1	00 - 22	Knob Function Select	bit0-3 KnobUp: 0= Tone1, 1= Tone2, 2= Tone3 bit4-7 KnobLo: 0=EQ, 1=Fx, 2=Arp	00	
		1F	1	00 - 01	Knob Zone on/off	off, on	01	This is available only when "Zone on/off" is set to on.

TOTAL SIZE = 32 20 (HEX)

Address			Size	Data Range (HEX)	Parameter Name	Settings	Default (HEX)	Notes
High	Mid	Low						
		0E	1	00 - 5F	Control Upper Knob Control Number	off, 1 - 95	07	
		0F	1	00 - 5F	Control Lower Knob Control Number	off, 1 - 95	0A	

TOTAL SIZE = 16 10 (HEX)

nn = zone number 00 - 03

Address			Size	Data Range (HEX)	Parameter Name	Settings	Default (HEX)	Notes
High	Mid	Low						
32	nn	00	1	00 - 3F	Transmit Channel, MIDI/TG Switch	bit6: reserved bit5: TG off, on bit4: MIDI off, on bit0-3: Ch 1..16	Zone1: 30 Other: 00	
		01	1	3D - 43	Octave	-3..+3	40	
		02	1	35 - 4B	Transpose	-11..+11 (semitones)	40	
		03	1	00 - 7F	Note Limit Low	C-2..G8	00	
		04	1	00 - 7F	Note Limit High	C-2..G8	7F	
		05	1		reserved		7F	
		06	1	00 - 7F	MIDI Volume	0..127	64	
		07	1	00 - 7F	MIDI Pan	0..127	40	
		08	1	00 - 7F	MIDI Bank MSB	0..127	00	
		09	1	00 - 7F	MIDI Bank LSB	0..127	00	
		0A	1	00 - 7F	MIDI Program Number	1..128	00	
		0B	1	00 - 1F	reserved Transmit Program Change for MIDI Transmit Bank Select for MIDI reserved Transmit Program Change for TG Transmit Bank Select for TG	bit6-5: reserved bit4: off, on Program Change bit3: off, on Bank Select bit2: reserved bit1: off, on Program Change bit0: off, on Bank Select	00	
		0C	1	00 - 7F	Transmit PB reserved Transmit Assignable Switch 2 Transmit Assignable Switch 1 Transmit Sustain Transmit Pan Transmit Volume/Expression	bit6: off, on PB bit5: reserved bit4: off, on Assignable Switch 2 bit3: off, on Assignable Switch 1 bit2: off, on Sustain bit1: off, on Pan bit0: off, on Volume/Expression	67	Ctrl#7, 11
		0D	1	00 - 7F	Transmit Assignable Knob reserved Transmit MW Transmit BC Transmit FC1 Transmit FS reserved	bit6: off, on Assignable Knob bit5: reserved bit4: off, on MW bit3: off, on BC bit2: off, on FC1 bit1: off, on FS bit0: reserved	7F	

MIDI PARAMETER CHANGE TABLE (PERFORMANCE COMMON)

Address			Size	Data Range (HEX)	Parameter Name	Settings	Default (HEX)	Notes
High	Mid	Low						
30	00	00	1	00, 20 - 7E	Performance Name 1	32..126 (ASCII)	l	
		01	1	00, 20 - 7E	Performance Name 2	32..126 (ASCII)	n	
		02	1	00, 20 - 7E	Performance Name 3	32..126 (ASCII)	i	
		03	1	00, 20 - 7E	Performance Name 4	32..126 (ASCII)	t	
		04	1	00, 20 - 7E	Performance Name 5	32..126 (ASCII)	i	
		05	1	00, 20 - 7E	Performance Name 6	32..126 (ASCII)	a	
		06	1	00, 20 - 7E	Performance Name 7	32..126 (ASCII)	l	
		07	1	00, 20 - 7E	Performance Name 8	32..126 (ASCII)	i	
		08	1	00, 20 - 7E	Performance Name 9	32..126 (ASCII)	z	
		09	1	00, 20 - 7E	Performance Name 10	32..126 (ASCII)	e	
		0A	1	00, 20 - 7E	Performance Name 11	32..126 (ASCII)	d	
		0B	1	00, 20 - 7E	Performance Name 12	32..126 (ASCII)	P	
		0C	1	00, 20 - 7E	Performance Name 13	32..126 (ASCII)	e	
		0D	1	00, 20 - 7E	Performance Name 14	32..126 (ASCII)	r	
		0E	1	00, 20 - 7E	Performance Name 15	32..126 (ASCII)	f	
		0F	1	00, 20 - 7E	Performance Name 16	32..126 (ASCII)	o	
		10	1	00, 20 - 7E	Performance Name 17	32..126 (ASCII)	r	
		11	1	00, 20 - 7E	Performance Name 18	32..126 (ASCII)	m	
		12	1	00, 20 - 7E	Performance Name 19	32..126 (ASCII)		
		13	1	00, 20 - 7E	Performance Name 20	32..126 (ASCII)		
		14	1		reserved			
		15	1		reserved			
		16	1		reserved			
		17	1		reserved			
		18	1	00 - 07	Performance Category (Main)	0..7	07 (NoAsg)	
		19	1	00 - 0B	Performance Category (Sub)	0..11	00 (-)	
		1A	1		reserved			
		1B	1		reserved			
		1C	1		reserved			
		1D	1		reserved			
30	00	1E	1	00 - 22	Knob Function Select	bit0-3 KnobUp: 0= Tone1, 1= Tone2, 2= Tone3 bit4-7 KnobLo: 0= EQ, 1= Fx, 2= Arp	00	
		1F	1	01 - 7F	Pan	L63..C..R63	40	
		20	1		reserved			
		21	1	00 - 7F	AEG Attack Time	-64..+63	40	
		22	1	00 - 7F	AEG Decay Time	-64..+63	40	
		23	1	00 - 7F	AEG Sustain Level	-64..+63	40	
		24	1	00 - 7F	AEG Release Time	-64..+63	40	
		25	1	00 - 7F	FEG Attack Time	-64..+63	40	
		26	1	00 - 7F	FEG Decay Time	-64..+63	40	
		27	1		reserved			
		28	1	00 - 7F	FEG Release Time	-64..+63	40	
		29	1	00 - 7F	FEG Depth	-64..+63	40	
		2A	1	00 - 7F	Cutoff Frequency	-64..+63	40	
		2B	1	00 - 7F	Resonance	-64..+63	40	
		2C	1		reserved			
		2D	1		reserved			
		2E	1	00 - 7F	EQ Low Frequency	-64..+63	40	
		2F	1	00 - 7F	EQ Low Gain	-64..+63	40	
		30	1		reserved			
		31	1	00 - 7F	EQ Mid Frequency	-64..+63	40	
		32	1	00 - 7F	EQ Mid Gain	-64..+63	40	
		33	1	00 - 7F	EQ Mid Q	-64..+63	40	
		34	1		reserved			
		35	1	00 - 7F	EQ High Frequency	-64..+63	40	
		36	1	00 - 7F	EQ High Gain	-64..+63	40	
		37	1		reserved			
		38	1	00 - 7F	Volume	0..127	7F	
		39	1	00 - 7F	Portamento Time	-64..+63	40	
		3A	1	00 - 01	Portamento Switch	off, on	01	
		3B	1	00 - 7F	Reverb Send	0..127	7F	
		3C	1	00 - 7F	Chorus Send	0..127	7F	
30	00	3D	1		reserved			
		3E	1		reserved			
		3F	1	00 - 01	Assignable Switch 1 Mode	momentary, latch	01	
		40	1	00 - 01	Assignable Switch 2 Mode	momentary, latch	01	
		41	1		reserved			
		42	1	01 - 7F	Split Point	C#-2..G8	3C	
		43	1	00 - 01	Split Switch	off, on	00	
		44	1		reserved			
		45	1		reserved			
		46	1		reserved			
		47	1		reserved			
		48	1		reserved			
		49	1		reserved			
		4A	1		reserved			
		4B	1	01 - 02	A/D Input Insertion Connect Type	ins A>B, ins B>A	01	

Address			Size	Data Range (HEX)	Parameter Name	Settings	Default (HEX)	Notes	
High	Mid	Low							
			4C	4	00 - 00 00 - 20 00 - 00 00 - 0F	Insertion Part Sw	1st bit6-0: reserved 2nd bit6: reserved 2nd bit5: off, on A/D Part 2nd bit4-0: reserved 3rd bit6-0: reserved 4th bit6-4: reserved 4th bit3: off, on Part 4 4th bit2: off, on Part 3 4th bit1: off, on Part 2 4th bit0: off, on Part 1	00 00 00 07	Up to three parts can be turned on simultaneously.

TOTAL SIZE = 80 50 (HEX)

Address			Size	Data Range (HEX)	Parameter Name	Settings	Default (HEX)	Notes
High	Mid	Low						
30	30	00	1	00 - 05	ARP SF Select	SF1 - SF6	00	
		01	1		reserved			
		02	2	00 - 02 05 - 2C	ARP Tempo	5..300	00 5A	
		04	1	00 - 01	ARP Common Switch	off, on	00	
		05	1	00 - 07	ARP Sync Quantize Value	off, 32th, 16th_Triplet, 16th, 8th_Triplet, 8th, 4th_Triplet, 4th	00	
		06	2	00 - 01 1C - 64	ARP Quantize Strength Offset	-100 ... +100	00 80	
		08	2	00 - 01 1C - 64	ARP Gate Time Rate Offset	-100 ... +100	01 00	
		0A	2	00 - 01 1C - 64	ARP Velocity Rate Offset	-100 ... +100	01 00	
		0C	2	00 - 01 08 - 78	ARP Swing Offset	-120 ... +120	01 00	

TOTAL SIZE = 14 0E (HEX)

Address			Size	Data Range (HEX)	Parameter Name	Settings	Default (HEX)	Notes
High	Mid	Low						
30	01	00	2	00 - 7F 00 - 7F	Reverb Type	Refer to the "Effect Type List."	01 00	Rev-X Hall
		02	1	00 - 7F	Preset Number		00	Basic
		03	1		reserved			
		04	2	00 - 7F 00 - 7F	Reverb Parameter 1	Refer to the "Effect Parameter List."		Init value for Rev-X Hall / Basic
		06	2	00 - 7F 00 - 7F	Reverb Parameter 2			Init value for Rev-X Hall / Basic
		08	2	00 - 7F 00 - 7F	Reverb Parameter 3			Init value for Rev-X Hall / Basic
		0A	2	00 - 7F 00 - 7F	Reverb Parameter 4			Init value for Rev-X Hall / Basic
		0C	2	00 - 7F 00 - 7F	Reverb Parameter 5			Init value for Rev-X Hall / Basic
		0E	2	00 - 7F 00 - 7F	Reverb Parameter 6			Init value for Rev-X Hall / Basic
		10	2	00 - 7F 00 - 7F	Reverb Parameter 7			Init value for Rev-X Hall / Basic
		12	2	00 - 7F 00 - 7F	Reverb Parameter 8			Init value for Rev-X Hall / Basic
		14	2	00 - 7F 00 - 7F	Reverb Parameter 9			Init value for Rev-X Hall / Basic
		16	2	00 - 7F 00 - 7F	Reverb Parameter 10			Init value for Rev-X Hall / Basic
		18	2	00 - 7F 00 - 7F	Reverb Parameter 11			Init value for Rev-X Hall / Basic
		1A	2	00 - 7F 00 - 7F	Reverb Parameter 12			Init value for Rev-X Hall / Basic
		1C	2	00 - 7F 00 - 7F	Reverb Parameter 13			Init value for Rev-X Hall / Basic
		1E	2	00 - 7F 00 - 7F	Reverb Parameter 14			Init value for Rev-X Hall / Basic
		20	2	00 - 7F 00 - 7F	Reverb Parameter 15			Init value for Rev-X Hall / Basic
		22	2	00 - 7F 00 - 7F	Reverb Parameter 16			Init value for Rev-X Hall / Basic
		24	1	00 - 7F	Reverb Return	---dB...0dB...+6dB (0...96...127)	40	
		25	1	01 - 7F	Reverb Pan	L63..C..R63	40	

TOTAL SIZE = 38 26 (HEX)

Address			Size	Data Range (HEX)	Parameter Name	Settings	Default (HEX)	Notes
High	Mid	Low						
30	02	00	2	00 - 7F 00 - 7F	Chorus Type	Refer to the "Effect Type List."	03 00	G Chorus
		02	1	00 - 7F	Preset Number		00	Basic
		03	1		reserved			
		04	2	00 - 7F 00 - 7F	Chorus Parameter 1	Refer to the "Effect Parameter List."		Init value for G Chorus / Basic
		06	2	00 - 7F 00 - 7F	Chorus Parameter 2			Init value for G Chorus / Basic
		08	2	00 - 7F 00 - 7F	Chorus Parameter 3			Init value for G Chorus / Basic

Address			Size	Data Range (HEX)	Parameter Name	Settings	Default (HEX)	Notes
High	Mid	Low						
		0A	2	00 - 7F 00 - 7F	Chorus Parameter 4	:	Init value for G Chorus / Basic	
		0C	2	00 - 7F 00 - 7F	Chorus Parameter 5	:	Init value for G Chorus / Basic	
		0E	2	00 - 7F 00 - 7F	Chorus Parameter 6	:	Init value for G Chorus / Basic	
		10	2	00 - 7F 00 - 7F	Chorus Parameter 7	:	Init value for G Chorus / Basic	
		12	2	00 - 7F 00 - 7F	Chorus Parameter 8	:	Init value for G Chorus / Basic	
		14	2	00 - 7F 00 - 7F	Chorus Parameter 9	:	Init value for G Chorus / Basic	
		16	2	00 - 7F 00 - 7F	Chorus Parameter 10	:	Init value for G Chorus / Basic	
		18	2	00 - 7F 00 - 7F	Chorus Parameter 11	:	Init value for G Chorus / Basic	
		1A	2	00 - 7F 00 - 7F	Chorus Parameter 12	:	Init value for G Chorus / Basic	
		1C	2	00 - 7F 00 - 7F	Chorus Parameter 13	:	Init value for G Chorus / Basic	
		1E	2	00 - 7F 00 - 7F	Chorus Parameter 14	:	Init value for G Chorus / Basic	
		20	2	00 - 7F 00 - 7F	Chorus Parameter 15	:	Init value for G Chorus / Basic	
		22	2	00 - 7F 00 - 7F	Chorus Parameter 16	:	Init value for G Chorus / Basic	
		24	1	00 - 7F	Chorus Return	--odB...0dB...+6dB (0...96...127)	60	
		25	1	01 - 7F	Chorus Pan	L63...C...R63	40	
		26	1	00 - 7F	Send Chorus To Reverb	--odB...0dB (0...127)	00	
		27	1		reserved			

TOTAL SIZE = 40 28 (HEX)

Address			Size	Data Range (HEX)	Parameter Name	Settings	Default (HEX)	Notes
High	Mid	Low						
30	03	00	2	00 - 7F 00 - 7F	Insertion A Type	Refer to the "Effect Type List."	00 00	For A/D Part
	02	1		00 - 7F	Preset Number		00	
	03	1			reserved			
	04	2		00 - 7F 00 - 7F	Insertion A Parameter 1	Refer to the "Effect Parameter List."	00 00	
	06	2		00 - 7F 00 - 7F	Insertion A Parameter 2	:	00 00	
	08	2		00 - 7F 00 - 7F	Insertion A Parameter 3	:	00 00	
	0A	2		00 - 7F 00 - 7F	Insertion A Parameter 4	:	00 00	
	0C	2		00 - 7F 00 - 7F	Insertion A Parameter 5	:	00 00	
	0E	2		00 - 7F 00 - 7F	Insertion A Parameter 6	:	00 00	
	10	2		00 - 7F 00 - 7F	Insertion A Parameter 7	:	00 00	
	12	2		00 - 7F 00 - 7F	Insertion A Parameter 8	:	00 00	
	14	2		00 - 7F 00 - 7F	Insertion A Parameter 9	:	00 00	
	16	2		00 - 7F 00 - 7F	Insertion A Parameter 10	:	00 00	
	18	2		00 - 7F 00 - 7F	Insertion A Parameter 11	:	00 00	
	1A	2		00 - 7F 00 - 7F	Insertion A Parameter 12	:	00 00	
	1C	2		00 - 7F 00 - 7F	Insertion A Parameter 13	:	00 00	
	1E	2		00 - 7F 00 - 7F	Insertion A Parameter 14	:	00 00	
	20	2		00 - 7F 00 - 7F	Insertion A Parameter 15	:	00 00	
	22	2		00 - 7F 00 - 7F	Insertion A Parameter 16	:	00 00	

TOTAL SIZE = 36 24 (HEX)

Address			Size	Data Range (HEX)	Parameter Name	Settings	Default (HEX)	Notes
High	Mid	Low						
30	04	00	2	00 - 7F 00 - 7F	Insertion B Type	Refer to the "Effect Type List."	00 00	For A/D Part
	02	1		00 - 7F	Preset Number		00	
	03	1			reserved			
	04	2		00 - 7F 00 - 7F	Insertion B Parameter 1	Refer to the "Effect Parameter List."	00 00	
	06	2		00 - 7F 00 - 7F	Insertion B Parameter 2	:	00 00	
	08	2		00 - 7F 00 - 7F	Insertion B Parameter 3	:	00 00	
	0A	2		00 - 7F 00 - 7F	Insertion B Parameter 4	:	00 00	
	0C	2		00 - 7F 00 - 7F	Insertion B Parameter 5	:	00 00	

Address			Size	Data Range (HEX)	Parameter Name	Settings	Default (HEX)	Notes
High	Mid	Low						
		0E	2	00 - 7F 00 - 7F	Insertion B Parameter 6	:	00 00	
		10	2	00 - 7F 00 - 7F	Insertion B Parameter 7	:	00 00	
		12	2	00 - 7F 00 - 7F	Insertion B Parameter 8	:	00 00	
		14	2	00 - 7F 00 - 7F	Insertion B Parameter 9	:	00 00	
		16	2	00 - 7F 00 - 7F	Insertion B Parameter 10	:	00 00	
		18	2	00 - 7F 00 - 7F	Insertion B Parameter 11	:	00 00	
		1A	2	00 - 7F 00 - 7F	Insertion B Parameter 12	:	00 00	
		1C	2	00 - 7F 00 - 7F	Insertion B Parameter 13	:	00 00	
		1E	2	00 - 7F 00 - 7F	Insertion B Parameter 14	:	00 00	
		20	2	00 - 7F 00 - 7F	Insertion B Parameter 15	:	00 00	
		22	2	00 - 7F 00 - 7F	Insertion B Parameter 16	:	00 00	

TOTAL SIZE = 36 24 (HEX)

Address			Size	Data Range (HEX)	Parameter Name	Settings	Default (HEX)	Notes
High	Mid	Low						
30	10	00	1	34 - 4C	EQ Low Gain	-12 - +12 [dB]	40	
		01	1	04 - 28	EQ Low Frequency	32 - 2000 [Hz]	0C	When setting the EQ shape peaking type, the range is 63Hz - 2.0kHz.
		02	1	01 - 78	EQ Low Q	0.1 - 12.0	07	When setting the EQ shape shelving type, this is not available.
		03	1	00 - 01	EQ Low Shape	shelv, peak	00	
		04	1	34 - 4C	EQ Low-Mid Gain	-12 - +12 [dB]	40	
		05	1	0E - 36	EQ Low-Mid Frequency	100 - 10.0 [kHz]	14	
		06	1	01 - 78	EQ Low-Mid Q	0.1 - 12.0	07	
		07	1		reserved			
		08	1	34 - 4C	EQ Mid Gain	-12 - +12 [dB]	40	
		09	1	0E - 36	EQ Mid Frequency	100 - 10.0 [kHz]	1C	
		0A	1	01 - 78	EQ Mid Q	0.1 - 12.0	07	
		0B	1		reserved			
		0C	1	34 - 4C	EQ High-Mid Gain	-12 - +12 [dB]	40	
		0D	1	0E - 36	EQ High-Mid Frequency	100 - 10.0 [kHz]	2C	
		0E	1	01 - 78	EQ High-Mid Q	0.1 - 12.0	07	
		0F	1		reserved			
		10	1	34 - 4C	EQ High Gain	-12 - +12 [dB]	40	
		11	1	1C - 3A	EQ High Frequency	0.5 - 16.0 [kHz]	34	
		12	1	01 - 78	EQ High Q	0.1 - 12.0	07	When setting the EQ shape shelving type, this is not available.
		13	1	00 - 01	EQ High Shape	shelv, peak	00	

TOTAL SIZE = 20 14 (HEX)

Address			Size	Data Range (HEX)	Parameter Name	Settings	Default (HEX)	Notes
High	Mid	Low						
30	11	00	2	00 - 7F 00 - 7F	Master Effect Type	Refer to the "Effect Type List."	08 20	Multi Band Comp
	02	1		00 - 7F	Preset Number		00	Basic
	03	1			reserved			
	04	2		00 - 7F 00 - 7F	Master Effect Parameter 1	Refer to the "Effect Parameter List."		Init value for Multi Band Comp / Basic
	06	2		00 - 7F 00 - 7F	Master Effect Parameter 2	:		Init value for Multi Band Comp / Basic
	08	2		00 - 7F 00 - 7F	Master Effect Parameter 3	:		Init value for Multi Band Comp / Basic
	0A	2		00 - 7F 00 - 7F	Master Effect Parameter 4	:		Init value for Multi Band Comp / Basic
	0C	2		00 - 7F 00 - 7F	Master Effect Parameter 5	:		Init value for Multi Band Comp / Basic
	0E	2		00 - 7F 00 - 7F	Master Effect Parameter 6	:		Init value for Multi Band Comp / Basic
	10	2		00 - 7F 00 - 7F	Master Effect Parameter 7	:		Init value for Multi Band Comp / Basic
	12	2		00 - 7F 00 - 7F	Master Effect Parameter 8	:		Init value for Multi Band Comp / Basic
	14	2		00 - 7F 00 - 7F	Master Effect Parameter 9	:		Init value for Multi Band Comp / Basic
	16	2		00 - 7F 00 - 7F	Master Effect Parameter 10	:		Init value for Multi Band Comp / Basic
	18	2		00 - 7F 00 - 7F	Master Effect Parameter 11	:		Init value for Multi Band Comp / Basic
	1A	2		00 - 7F 00 - 7F	Master Effect Parameter 12	:		Init value for Multi Band Comp / Basic

MIDI PARAMETER CHANGE TABLE (PERFORMANCE PART)

Address			Size	Data Range (HEX)	Parameter Name	Settings	Default (HEX)	Notes
High	Mid	Low						
		1C	2	00 – 7F 00 – 7F	Master Effect Parameter 13	:	Init value for Multi Band Comp / Basic	
		1E	2	00 – 7F 00 – 7F	Master Effect Parameter 14	:	Init value for Multi Band Comp / Basic	
		20	2	00 – 7F 00 – 7F	Master Effect Parameter 15	:	Init value for Multi Band Comp / Basic	
		22	2	00 – 7F 00 – 7F	Master Effect Parameter 16	:	Init value for Multi Band Comp / Basic	
		24	1	00 – 01	Master Effect Switch	off, on	00	
		25	1		reserved			

TOTAL SIZE = 38 26 (HEX)

Address			Size	Data Range (HEX)	Parameter Name	Settings	Default (HEX)	Notes
High	Mid	Low						
31	pp	00	1	00 – 01	Part Switch	off, on	01	
		01	1	00 – 7F	Bank Select MSB	0 – 127	3F	
		02	1	00 – 7F	Bank Select LSB	0 – 127	00	
		03	1	00 – 7F	Program Number	1 – 128	00	
		04	1		reserved			
		05	1	00 – 01	Mono/Poly	mono, poly	01	
		06	1	01 – 7F	Velocity Limit Low	1 – 127	01	
		07	1	01 – 7F	Velocity Limit High	1 – 127	7F	
		08	1	00 – 7F	Note Limit Low	C-2 – G8	00	
		09	1	00 – 7F	Note Limit High	C-2 – G8	7F	
		0A	1	10 – 58	Pitch Bend Range Upper	-48 – +24	42	
		0B	1	10 – 58	Pitch Bend Range Lower	-48 – +24	3E	
		0C	1	00 – 7F	Velocity Sensitivity Depth	0 – 127	40	
		0D	1	00 – 7F	Velocity Sensitivity Offset	0 – 127	40	
		0E	1	00 – 7F	Volume	0 – 127	64	
		0F	1	01 – 7F	Pan	L63 – C – R63	40	
		10	2	00 – 0F 00 – 0F	Detune	-12.8 – +12.7 [Hz] 1st bit3-0 → bit7-4, 2nd bit3-0 → bit3-0	08 00 (80)	
		12	1	00 – 7F	Reverb Send	0 – 127	0C	
		13	1	00 – 7F	Chorus Send	0 – 127	00	
		14	1		reserved			
		15	1	00 – 7F	Dry Level	0 – 127	7F	
		16	1	28 – 58	Note Shift	-24 – +24 [semitones]	40	
		17	1		reserved			
		18	1	00 – 01	Param. with Voice	off, on	00	
		19	1	00 – 01	Voice with Arp	off, on	00	
		1A	1	00 – 01	Portamento Switch	off, on	00	
		1B	1	00 – 7F	Portamento Time	0 – 127	40	
		1C	1	00 – 01	Portamento Mode	fingered, fulltime	01	
		1D	1	00 – 02	Split Lower/Upper	both, lower, upper	00	
		1E	1	00 – 01	USB Audio Output Select	USB 1/2, USB 3/4	01	This is available only when the audio connect mode is set to 2 Stereo Rec mode.
31	pp	1F	1	18 – 7C	Receive PB Receive AT reserved reserved Receive Control Change reserved	bit6: off, on PB bit5: off, on AT bit4: reserved bit3: reserved bit2: off, on Control Change bit1-0: reserved	7C	
		20	1	02 – 6F	Receive FC2 Receive FC1 reserved Receive MW Receive Sustain/Sostenuto reserved Receive Expression	bit6: off, on FC2 bit5: off, on FC1 bit4: reserved bit3: off, on MW bit2: off, on Sustain/Sostenuto bit1: reserved bit0: off, on Expression	6F	Only for Normal Voices
		21	1	00 – 7F	Receive Assignable Switch 2 Receive Assignable Switch 1 Receive Assignable Knob 2 Receive Assignable Knob 1 Receive RB Receive BC Receive FS	bit6: off, on ASW2 bit5: off, on ASW1 bit4: off, on AKN2 bit3: off, on AKN1 bit2: off, on RB bit1: off, on BC bit0: off, on FS	7F	
31	pp	22	1	00 – 01	Voice Element Pan	off, on	01	
		23	1	00 – 7F	AEG Attack Time	-64 – +63	40	
		24	1	00 – 7F	AEG Decay Time	-64 – +63	40	
		25	1	00 – 7F	AEG Sustain Level	-64 – +63	40	Only for Normal Voice
		26	1	00 – 7F	AEG Release Time	-64 – +63	40	Only for Normal Voice
		27	1	00 – 7F	FEG Attack Time	-64 – +63	40	Only for Normal Voice
		28	1	00 – 7F	FEG Decay Time	-64 – +63	40	Only for Normal Voice
		29	1	00 – 7F	FEG Sustain Level	-64 – +63	40	Only for Normal Voice
		2A	1	00 – 7F	FEG Release Time	-64 – +63	40	Only for Normal Voice
		2B	1	00 – 7F	FEG Depth	-64 – +63	40	Only for Normal Voice
		2C	1		reserved			
		2D	1	00 – 7F	Filter Cutoff Frequency	-64 – +63	40	
		2E	1	00 – 7F	Filter Resonance/Width	-64 – +63	40	
31	pp	2F	1		reserved			
		30	2	00 – 01 2E – 36	EQ Low Frequency	50.1 – 2.00k	00 36	
		32	1	20 – 60	EQ Low Gain	-32 – +32 (-12.00db – +12.00db)	40	

Address			Size	Data Range (HEX)	Parameter Name	Settings	Default (HEX)	Notes
High	Mid	Low						
		33	1		reserved			
		34	2	00 - 01 53 - 71	EQ Mid Frequency	139.7 - 10.1k	01 0D	
		36	1	20 - 60	EQ Mid Gain	-32 - +32 (-12.00db - +12.00db)	40	
		37	1	00 - 1F	EQ Mid Q	0 - 31 (0.7 - 10.3)	00	
		38	2	01 - 01 03 - 7F	EQ High Frequency	503.8 - 14k	01 67	
		3A	1	20 - 60	EQ High Gain	-32 - +32 (12.00db - +12.00db)	40	
		3B	1		reserved			
31	pp	3C	1	00 - 7F	Assignable Knob 1 Value	-64 - +63	40	
		3D	1	00 - 7F	Assignable Knob 2 Value	-64 - +63	40	

TOTAL SIZE = 62 3E (HEX)
pp = part number 00 - 03

Address			Size	Data Range (HEX)	Parameter Name	Settings	Default (HEX)	Notes
High	Mid	Low						
34	pp	00	1	00 - 01	ARP Switch	off, on	00	
		01	1	00 - 01	ARP MIDI Out Switch	off, on	00	
		02	1	00 - 10	ARP Transmit Channel	1..16, kbd-ch	Part No.	
		03	1	00 - 01	ARP Play Only	off, on	00	
		04	1		reserved			
		05	1		reserved			
		06	1	00 - 01	ARP Loop	off, on	01	
		07	1	00 - 02	ARP Hold	sync-off, off, on	01	
		08	1	00 - 06	ARP Unit Multiply	50%, 66%, 75%, 100%, 133%, 150%, 200%	03	
		09	1	00 - 7F	ARP Note Limit Low	C-2..G8	00	
		0A	1	00 - 7F	ARP Note Limit High	C-2..G8	7F	
		0B	1	01 - 7F	ARP Velocity Limit Low	1 - 127	01	
		0C	1	01 - 7F	ARP Velocity Limit High	1 - 127	7F	
		0D	1	00 - 04	ARP Key Mode	sort, thru, direct, sort+direct, thru+direct	00	
		0E	1	00 - 01	ARP Velocity Mode	original, thru	00	
		0F	1	00 - 01	ARP Change Timing	realtime, measure	01	
		10	1	01 - 07	ARP Quantize Value	32th, 16th_Triplet, 16th, 8th_Triplet, 8th, 4th_Triplet, 4th	03	
		11	1	00 - 64	ARP Quantize Strength	0..100%	00	
		12	2	00 - 01 00 - 48	ARP Velocity Rate	0..200%	00 64	
		14	2	00 - 01 00 - 48	ARP Gate Time Rate	0..200%	00 64	
		16	1		reserved			
		17	1		reserved			
		18	1		reserved			
		19	1		reserved			
		1A	2	00 - 01 08 - 78	ARP Swing	-120 ... 0 ... +120	01 00	
		1C	1	00 - 7F	ARP Accent Velocity Threshold	off, 1 ... 127	40	
		1D	1	00 - 01	ARP Accent Start Quantize	off, on	01	
		1E	1	3D - 43	ARP Octave Range	-3 ... 0 ... +3	40	
		1F	1	36 - 4A	ARP Output Octave Shift	-10 ... 0 ... +10	40	
		20	1	00 - 01	ARP Trigger Mode	gate, toggle	00	
		21	1	00 - 01	ARP Random SFX	off, on	01	
		22	1	00 - 01	ARP Random SFX Key on Control	off, on	01	
		23	1	00 - 7F	ARP Random SFX Velocity Offset	-64 ... 0 ... +63	40	
		24	2	00 - 01 1C - 64	ARP Assign Velocity Rate Offset SF1	-100 ... 0 ... +100	01 00	
		26	2	00 - 01 1C - 64	ARP Assign Gate Time Offset SF1	-100 ... 0 ... +100	01 00	
		28	2	00 - 01 1C - 64	ARP Assign Velocity Rate Offset SF2	-100 ... 0 ... +100	01 00	
		2A	2	00 - 01 1C - 64	ARP Assign Gate Time Offset SF2	-100 ... 0 ... +100	01 00	
		2C	2	00 - 01 1C - 64	ARP Assign Velocity Rate Offset SF3	-100 ... 0 ... +100	01 00	
		2E	2	00 - 01 1C - 64	ARP Assign Gate Time Offset SF3	-100 ... 0 ... +100	01 00	
		30	2	00 - 01 1C - 64	ARP Assign Velocity Rate Offset SF4	-100 ... 0 ... +100	01 00	
		32	2	00 - 01 1C - 64	ARP Assign Gate Time Offset SF4	-100 ... 0 ... +100	01 00	
		34	2	00 - 01 1C - 64	ARP Assign Velocity Rate Offset SF5	-100 ... 0 ... +100	01 00	
		36	2	00 - 01 1C - 64	ARP Assign Gate Time Offset SF5	-100 ... 0 ... +100	01 00	
		38	2	00 - 01 1C - 64	ARP Assign Velocity Rate Offset SF6	-100 ... 0 ... +100	01 00	
		3A	2	00 - 01 1C - 64	ARP Assign Gate Time Offset SF6	-100 ... 0 ... +100	01 00	

Address			Size	Data Range (HEX)	Parameter Name	Settings	Default (HEX)	Notes
High	Mid	Low						
		3C	2	00 - 34 00 - 7B 40 - 41 00 - 7F	ARP SF1 Assign Type	off, Preset 0001 ... 6779, User 001 ... 256	04 6E	MA_Pf Arp1
		3E	2	00 - 34 00 - 7B 40 - 41 00 - 7F	ARP SF2 Assign Type	off, Preset 0001 ... 6779, User 001 ... 256	00 00	off
		40	2	00 - 34 00 - 7B 40 - 41 00 - 7F	ARP SF3 Assign Type	off, Preset 0001 ... 6779, User 001 ... 256	00 00	off
		42	2	00 - 34 00 - 7B 40 - 41 00 - 7F	ARP SF4 Assign Type	off, Preset 0001 ... 6779, User 001 ... 256	00 00	off
		44	2	00 - 34 00 - 7B 40 - 41 00 - 7F	ARP SF5 Assign Type	off, Preset 0001 ... 6779, User 001 ... 256	00 00	off
		46	2	00 - 34 00 - 7B 40 - 41 00 - 7F	ARP SF6 Assign Type	off, Preset 0001 ... 6779, User 001 ... 256	00 00	off

TOTAL SIZE = 72 48 (HEX)
pp = part number 00 - 03

Address			Size	Data Range (HEX)	Parameter Name	Settings	Default (HEX)	Notes
High	Mid	Low						
35	4n	00	1	00 - 03	Audio Input Mode	L mono, R mono, L+R mono, stereo	03	Audio In Part (A/D, USB)
		01	1	00 - 7F	Audio Input Part Volume	0 - 127	64	
		02	1	01 - 7F	Audio Input Part Pan	L63 - C - R63	40	
		03	1	00 - 7F	Audio Input Part Reverb Send	0 - 127	0C	
		04	1	00 - 7F	Audio Input Part Chorus Send	0 - 127	00	
		05	1		reserved			
		06	1	00 - 7F	Audio Input Part Dry Level	0 - 127	7F	
		07	1		reserved			

TOTAL SIZE = 8 08 (HEX)
n = part number 00 - 00

MIDI PARAMETER CHANGE TABLE (SONG/PATTERN COMMON)

Address			Size	Data Range (HEX)	Parameter Name	Settings	Default (HEX)	Notes
High	Mid	Low						
36	00	00	1		reserved			
		01	1		reserved			
		02	1		reserved			
		03	1		reserved			
		04	1		reserved			
		05	1		reserved			
		06	1		reserved			
		07	1		reserved			
		08	1		reserved			
		09	1		reserved			
		0A	1		reserved			
		0B	1		reserved			
		0C	1		reserved			
		0D	1		reserved			
		0E	1		reserved			
		0F	1		reserved			
		10	1		reserved			
		11	1		reserved			
		12	1		reserved			
		13	1		reserved			
		14	1		reserved			
		15	1		reserved			
		16	1		reserved			
		17	1		reserved			
		18	1		reserved			
		19	1		reserved			
		1A	1		reserved			
		1B	1		reserved			
		1C	1		reserved			
		1D	1		reserved			
36	00	1E	1	00 - 22	Knob Function Select	bit0-3 KnobUp: 0= Tone1, 1= Tone2, 2= Tone3 bit4-7 KnobLo: 0=EQ, 1=Fx, 2=Arp	00	
		1F	1		reserved			
		20	1		reserved			
		21	1		reserved			
		22	1		reserved			
		23	1		reserved			
		24	1		reserved			
		25	1		reserved			
		26	1		reserved			
		27	1		reserved			
		28	1		reserved			
		29	1		reserved			
		2A	1		reserved			
		2B	1		reserved			
		2C	1		reserved			
		2D	1		reserved			
		2E	1		reserved			
		2F	1		reserved			
		30	1		reserved			
		31	1		reserved			
		32	1		reserved			
		33	1		reserved			
		34	1		reserved			
		35	1		reserved			
		36	1		reserved			
		37	1		reserved			
		38	1		reserved			
		39	1		reserved			
		3A	1		reserved			
		3B	1		reserved			
		3C	1		reserved			
36	00	3D	1		reserved			
		3E	1		reserved			
		3F	1	00 - 01	Assignable Switch 1 Mode	momentary, latch	01	
		40	1	00 - 01	Assignable Switch 2 Mode	momentary, latch	01	
		41	1		reserved			
		42	1		reserved			
		43	1		reserved			
		44	1		reserved			
		45	1		reserved			
		46	1		reserved			
		47	1		reserved			
		48	1		reserved			
		49	1		reserved			
		4A	1		reserved			
		4B	1	01 - 02	A/D Input Insertion Connect Type	ins A>B, ins B>A	01	

Address			Size	Data Range (HEX)	Parameter Name	Settings	Default (HEX)	Notes
High	Mid	Low						
		4C	4	00 - 00 00 - 23 00 - 00 00 - 00	Insertion Part Sw	1st bit6-0: reserved 2nd bit6: reserved 2nd bit5: off, on A/D Part reserved 2nd bit4: reserved 2nd bit3: reserved 2nd bit2: reserved 2nd bit1: off, on Part 16 2nd bit0: off, on Part 15 3rd bit6: off, on Part 14 3rd bit5: off, on Part 13 3rd bit4: off, on Part 12 3rd bit3: off, on Part 11 3rd bit2: off, on Part 10 3rd bit1: off, on Part 9 3rd bit0: off, on Part 8 4th bit6: off, on Part 7 4th bit5: off, on Part 6 4th bit4: off, on Part 5 4th bit3: off, on Part 4 4th bit2: off, on Part 3 4th bit1: off, on Part 2 4th bit0: off, on Part 1	00 00 00 07	Up to three parts can be turned on simultaneously.

TOTAL SIZE = 80 50 (HEX)

Address			Size	Data Range (HEX)	Parameter Name	Settings	Default (HEX)	Notes
High	Mid	Low						
36	30	00	1	00 - 05	ARP SF Select	SF1 - SF6	00	
		01	1		reserved			
		02	2		reserved			
		04	1	00 - 01	ARP Common Switch	off, on	00	
		05	1	00 - 07	ARP Sync Quantize Value	off, 32th, 16th, Triplet, 16th, 8th, Triplet, 8th, 4th, Triplet, 4th	00	
		06	2	00 - 01 1C - 64	ARP Quantize Strength Offset	-100 ... +100	01 00	
		08	2	00 - 01 1C - 64	ARP Gate Time Rate Offset	-100 ... +100	01 00	
		0A	2	00 - 01 1C - 64	ARP Velocity Rate Offset	-100 ... +100	01 00	
		0C	2	00 -01 08 - 78	ARP Swing Offset	-120 ... +120	01 00	

TOTAL SIZE = 14 0E (HEX)

Address			Size	Data Range (HEX)	Parameter Name	Settings	Default (HEX)	Notes
High	Mid	Low						
36	01	00	2	00 - 7F 00 - 7F	Reverb Type	Refer to the "Effect Type List."	01 00	Rev-X Hall
		02	1	00 - 7F	Preset Number		00	Basic
		03	1		reserved			
		04	2	00 - 7F 00 - 7F	Reverb Parameter 1	Refer to the "Effect Parameter List."		Init value for Rev-X Hall / Basic
		06	2	00 - 7F 00 - 7F	Reverb Parameter 2	:		Init value for Rev-X Hall / Basic
		08	2	00 - 7F 00 - 7F	Reverb Parameter 3	:		Init value for Rev-X Hall / Basic
		0A	2	00 - 7F 00 - 7F	Reverb Parameter 4	:		Init value for Rev-X Hall / Basic
		0C	2	00 - 7F 00 - 7F	Reverb Parameter 5	:		Init value for Rev-X Hall / Basic
		0E	2	00 - 7F 00 - 7F	Reverb Parameter 6	:		Init value for Rev-X Hall / Basic
		10	2	00 - 7F 00 - 7F	Reverb Parameter 7	:		Init value for Rev-X Hall / Basic
		12	2	00 - 7F 00 - 7F	Reverb Parameter 8	:		Init value for Rev-X Hall / Basic
		14	2	00 - 7F 00 - 7F	Reverb Parameter 9	:		Init value for Rev-X Hall / Basic
		16	2	00 - 7F 00 - 7F	Reverb Parameter 10	:		Init value for Rev-X Hall / Basic
		18	2	00 - 7F 00 - 7F	Reverb Parameter 11	:		Init value for Rev-X Hall / Basic
		1A	2	00 - 7F 00 - 7F	Reverb Parameter 12	:		Init value for Rev-X Hall / Basic
		1C	2	00 - 7F 00 - 7F	Reverb Parameter 13	:		Init value for Rev-X Hall / Basic
		1E	2	00 - 7F 00 - 7F	Reverb Parameter 14	:		Init value for Rev-X Hall / Basic
		20	2	00 - 7F 00 - 7F	Reverb Parameter 15	:		Init value for Rev-X Hall / Basic
		22	2	00 - 7F 00 - 7F	Reverb Parameter 16	:		Init value for Rev-X Hall / Basic
		24	1	00 - 7F	Reverb Return	-->dB...0dB...+6dB (0...96...127)	40	
		25	1	01 - 7F	Reverb Pan	L63...C...R63	40	

TOTAL SIZE = 38 26 (HEX)

Address			Size	Data Range (HEX)	Parameter Name	Settings	Default (HEX)	Notes
High	Mid	Low						
36	02	00	2	00 - 7F 00 - 7F	Chorus Type	Refer to the "Effect Type List."	03 00	G Chorus
	02	01	1	00 - 7F	Preset Number		00	Basic
	03	01	1		reserved			
	04	2	2	00 - 7F 00 - 7F	Chorus Parameter 1	Refer to the "Effect Parameter List."		Init value for G Chorus / Basic
	06	2	2	00 - 7F 00 - 7F	Chorus Parameter 2	:		Init value for G Chorus / Basic
	08	2	2	00 - 7F 00 - 7F	Chorus Parameter 3	:		Init value for G Chorus / Basic
	0A	2	2	00 - 7F 00 - 7F	Chorus Parameter 4	:		Init value for G Chorus / Basic
	0C	2	2	00 - 7F 00 - 7F	Chorus Parameter 5	:		Init value for G Chorus / Basic
	0E	2	2	00 - 7F 00 - 7F	Chorus Parameter 6	:		Init value for G Chorus / Basic
	10	2	2	00 - 7F 00 - 7F	Chorus Parameter 7	:		Init value for G Chorus / Basic
	12	2	2	00 - 7F 00 - 7F	Chorus Parameter 8	:		Init value for G Chorus / Basic
	14	2	2	00 - 7F 00 - 7F	Chorus Parameter 9	:		Init value for G Chorus / Basic
	16	2	2	00 - 7F 00 - 7F	Chorus Parameter 10	:		Init value for G Chorus / Basic
	18	2	2	00 - 7F 00 - 7F	Chorus Parameter 11	:		Init value for G Chorus / Basic
	1A	2	2	00 - 7F 00 - 7F	Chorus Parameter 12	:		Init value for G Chorus / Basic
	1C	2	2	00 - 7F 00 - 7F	Chorus Parameter 13	:		Init value for G Chorus / Basic
	1E	2	2	00 - 7F 00 - 7F	Chorus Parameter 14	:		Init value for G Chorus / Basic
	20	2	2	00 - 7F 00 - 7F	Chorus Parameter 15	:		Init value for G Chorus / Basic
	22	2	2	00 - 7F 00 - 7F	Chorus Parameter 16	:		Init value for G Chorus / Basic
	24	1	1	00 - 7F	Chorus Return	--dB...0dB...+6dB (0...96...127)	60	
	25	1	1	01 - 7F	Chorus Pan	L63...C...R63	40	
	26	1	1	00 - 7F	Send Chorus To Reverb	--dB...0dB (0...127)	00	
	27	1	1		reserved			

TOTAL SIZE = 40 28 (HEX)

Address			Size	Data Range (HEX)	Parameter Name	Settings	Default (HEX)	Notes
High	Mid	Low						
36	03	00	2	00 - 7F 00 - 7F	Insertion A Type	Refer to the "Effect Type List."	00 00	For A/D Part
	02	01	1	00 - 7F	Preset Number		00	
	03	01	1		reserved			
	04	2	2	00 - 7F 00 - 7F	Insertion A Parameter 1	Refer to the "Effect Parameter List."	00 00	
	06	2	2	00 - 7F 00 - 7F	Insertion A Parameter 2	:	00 00	
	08	2	2	00 - 7F 00 - 7F	Insertion A Parameter 3	:	00 00	
	0A	2	2	00 - 7F 00 - 7F	Insertion A Parameter 4	:	00 00	
	0C	2	2	00 - 7F 00 - 7F	Insertion A Parameter 5	:	00 00	
	0E	2	2	00 - 7F 00 - 7F	Insertion A Parameter 6	:	00 00	
	10	2	2	00 - 7F 00 - 7F	Insertion A Parameter 7	:	00 00	
	12	2	2	00 - 7F 00 - 7F	Insertion A Parameter 8	:	00 00	
	14	2	2	00 - 7F 00 - 7F	Insertion A Parameter 9	:	00 00	
	16	2	2	00 - 7F 00 - 7F	Insertion A Parameter 10	:	00 00	
	18	2	2	00 - 7F 00 - 7F	Insertion A Parameter 11	:	00 00	
	1A	2	2	00 - 7F 00 - 7F	Insertion A Parameter 12	:	00 00	
	1C	2	2	00 - 7F 00 - 7F	Insertion A Parameter 13	:	00 00	
	1E	2	2	00 - 7F 00 - 7F	Insertion A Parameter 14	:	00 00	
	20	2	2	00 - 7F 00 - 7F	Insertion A Parameter 15	:	00 00	
	22	2	2	00 - 7F 00 - 7F	Insertion A Parameter 16	:	00 00	

TOTAL SIZE = 36 24 (HEX)

Address			Size	Data Range (HEX)	Parameter Name	Settings	Default (HEX)	Notes
High	Mid	Low						
36	04	00	2	00 - 7F 00 - 7F	Insertion B Type	Refer to the "Effect Type List."	00 00	For A/D Part
	02	01	1	00 - 7F	Preset Number		00	
	03	01	1		reserved			
	04	2	2	00 - 7F 00 - 7F	Insertion B Parameter 1	Refer to the "Effect Parameter List."	00 00	
	06	2	2	00 - 7F 00 - 7F	Insertion B Parameter 2	:	00 00	
	08	2	2	00 - 7F 00 - 7F	Insertion B Parameter 3	:	00 00	
	0A	2	2	00 - 7F 00 - 7F	Insertion B Parameter 4	:	00 00	
	0C	2	2	00 - 7F 00 - 7F	Insertion B Parameter 5	:	00 00	
	0E	2	2	00 - 7F 00 - 7F	Insertion B Parameter 6	:	00 00	
	10	2	2	00 - 7F 00 - 7F	Insertion B Parameter 7	:	00 00	
	12	2	2	00 - 7F 00 - 7F	Insertion B Parameter 8	:	00 00	
	14	2	2	00 - 7F 00 - 7F	Insertion B Parameter 9	:	00 00	
	16	2	2	00 - 7F 00 - 7F	Insertion B Parameter 10	:	00 00	
	18	2	2	00 - 7F 00 - 7F	Insertion B Parameter 11	:	00 00	
	1A	2	2	00 - 7F 00 - 7F	Insertion B Parameter 12	:	00 00	
	1C	2	2	00 - 7F 00 - 7F	Insertion B Parameter 13	:	00 00	
	1E	2	2	00 - 7F 00 - 7F	Insertion B Parameter 14	:	00 00	
	20	2	2	00 - 7F 00 - 7F	Insertion B Parameter 15	:	00 00	
	22	2	2	00 - 7F 00 - 7F	Insertion B Parameter 16	:	00 00	

TOTAL SIZE = 36 24 (HEX)

Address			Size	Data Range (HEX)	Parameter Name	Settings	Default (HEX)	Notes
High	Mid	Low						
36	10	00	1	34 - 4C	EQ Low Gain	-12 - +12 [dB]	40	
	01	1	1	04 - 28	EQ Low Frequency	32 - 2000 [Hz]	0C	When setting the EQ shape peaking type, the range is 63Hz - 2.0kHz.
	02	1	1	01 - 78	EQ Low Q	0.1 - 12.0	07	When setting the EQ shape shelving type, this is not available.
	03	1	1	00 - 01	EQ Low Shape	shelv, peak	00	
	04	1	1	34 - 4C	EQ Low-Mid Gain	-12 - +12 [dB]	40	
	05	1	1	0E - 36	EQ Low-Mid Frequency	100 - 10.0 [kHz]	14	
	06	1	1	01 - 78	EQ Low-Mid Q	0.1 - 12.0	07	
	07	1	1		reserved			
	08	1	1	34 - 4C	EQ Mid Gain	-12 - +12 [dB]	40	
	09	1	1	0E - 36	EQ Mid Frequency	100 - 10.0 [kHz]	1C	
	0A	1	1	01 - 78	EQ Mid Q	0.1 - 12.0	07	
	0B	1	1		reserved			
	0C	1	1	34 - 4C	EQ High-Mid Gain	-12 - +12 [dB]	40	
	0D	1	1	0E - 36	EQ High-Mid Frequency	100 - 10.0 [kHz]	2C	
	0E	1	1	01 - 78	EQ High-Mid Q	0.1 - 12.0	07	
	0F	1	1		reserved			
	10	1	1	34 - 4C	EQ High Gain	-12 - +12 [dB]	40	
	11	1	1	1C - 3A	EQ High Frequency	0.5 - 16.0 [kHz]	34	
	12	1	1	01 - 78	EQ High Q	0.1 - 12.0	07	When setting the EQ shape shelving type, this is not available.
	13	1	1	00 - 01	EQ High Shape	shelv, peak	00	

TOTAL SIZE = 20 14 (HEX)

MIDI PARAMETER CHANGE TABLE (SONG/PATTERN PART)

Address			Size	Data Range (HEX)	Parameter Name	Settings	Default (HEX)	Notes
High	Mid	Low						
36	11	00	2	00 - 7F 00 - 7F	Master Effect Type	Refer to the "Effect Type List."	08 20	Multi Band Comp
		02	1	00 - 7F	Preset Number		00	Basic
		03	1		reserved			
		04	2	00 - 7F 00 - 7F	Master Effect Parameter 1	Refer to the "Effect Parameter List."		Init value for Multi Band Comp / Basic
		06	2	00 - 7F 00 - 7F	Master Effect Parameter 2	:		Init value for Multi Band Comp / Basic
		08	2	00 - 7F 00 - 7F	Master Effect Parameter 3	:		Init value for Multi Band Comp / Basic
		0A	2	00 - 7F 00 - 7F	Master Effect Parameter 4	:		Init value for Multi Band Comp / Basic
		0C	2	00 - 7F 00 - 7F	Master Effect Parameter 5	:		Init value for Multi Band Comp / Basic
		0E	2	00 - 7F 00 - 7F	Master Effect Parameter 6	:		Init value for Multi Band Comp / Basic
		10	2	00 - 7F 00 - 7F	Master Effect Parameter 7	:		Init value for Multi Band Comp / Basic
		12	2	00 - 7F 00 - 7F	Master Effect Parameter 8	:		Init value for Multi Band Comp / Basic
		14	2	00 - 7F 00 - 7F	Master Effect Parameter 9	:		Init value for Multi Band Comp / Basic
		16	2	00 - 7F 00 - 7F	Master Effect Parameter 10	:		Init value for Multi Band Comp / Basic
		18	2	00 - 7F 00 - 7F	Master Effect Parameter 11	:		Init value for Multi Band Comp / Basic
		1A	2	00 - 7F 00 - 7F	Master Effect Parameter 12	:		Init value for Multi Band Comp / Basic
		1C	2	00 - 7F 00 - 7F	Master Effect Parameter 13	:		Init value for Multi Band Comp / Basic
		1E	2	00 - 7F 00 - 7F	Master Effect Parameter 14	:		Init value for Multi Band Comp / Basic
		20	2	00 - 7F 00 - 7F	Master Effect Parameter 15	:		Init value for Multi Band Comp / Basic
		22	2	00 - 7F 00 - 7F	Master Effect Parameter 16	:		Init value for Multi Band Comp / Basic
		24	1	00 - 01	Master Effect Switch	off, on	00	
		25	1		reserved			

TOTAL SIZE = 38 26 (HEX)

Address			Size	Data Range (HEX)	Parameter Name	Settings	Default (HEX)	Notes
High	Mid	Low						
37	pp	00	1		reserved			
		01	1	00 - 7F	Bank Select MSB	0 - 127	3F	
		02	1	00 - 7F	Bank Select LSB	0 - 127	00	
		03	1	00 - 7F	Program Number	1 - 128	00	
		04	1	00 - 0F, 7F	Receive Channel	1..16, off (7F)		Part No.
		05	1	00 - 01	Mono/Poly	mono, poly	01	
		06	1	01 - 7F	Velocity Limit Low	1 - 127	01	
		07	1	01 - 7F	Velocity Limit High	1 - 127	7F	
		08	1	00 - 7F	Note Limit Low	C-2 - G8	00	
		09	1	00 - 7F	Note Limit High	C-2 - G8	7F	
		0A	1	10 - 58	Pitch Bend Range Upper	-48 - +24	42	
		0B	1	10 - 58	Pitch Bend Range Lower	-48 - +24	3E	
		0C	1	00 - 7F	Velocity Sensitivity Depth	0 - 127	40	
		0D	1	00 - 7F	Velocity Sensitivity Offset	0 - 127	40	
		0E	1	00 - 7F	Volume	0 - 127	64	
		0F	1	01 - 7F	Pan	L63 - C - R63	40	
		10	2	00 - 0F 00 - 0F	Detune	-12.8 - +12.7 [Hz] 1st bit3-0 → bit7-4, 2nd bit3-0 → bit3-0	08 00 (80)	
		12	1	00 - 7F	Reverb Send	0 - 127	0C	
		13	1	00 - 7F	Chorus Send	0 - 127	00	
		14	1		reserved			
		15	1	00 - 7F	Dry Level	0 - 127	7F	
		16	1	28 - 58	Note Shift	-24 - +24 [semitones]	40	
		17	1		reserved			
		18	1	00 - 01	Param. with Voice	off, on	00	
		19	1	00 - 01	Voice with Arp	off, on	00	
		1A	1	00 - 01	Portamento Switch	off, on	00	
		1B	1	00 - 7F	Portamento Time	0 - 127	40	
		1C	1	00 - 01	Portamento Mode	fingered, fulltime	01	
		1D	1		reserved			
		1E	1	00 - 01	USB Audio Output Select	USB 1/2, USB 3/4	01	This is available only when the audio connect mode is set to 2 Stereo Rec mode.
37	pp	1F	1	18 - 7C	Receive PB Receive AT Receive Program Change Receive Bank Select Receive Control Change reserved	bit6: off, on PB bit5: off, on AT bit4: off, on Program Change bit3: off, on Bank Select bit2: off, on Control Change bit1-0: reserved	7C	
		20	1	02 - 6F	Receive FC2 Receive FC1 reserved Receive MW Receive Sustain/Sostenuto Receive Pan Receive Volume/Expression	bit6: off, on FC2 bit5: off, on FC1 bit4: reserved bit3: off, on MW bit2: off, on Sustain/Sostenuto bit1: off, on Pan bit0: off, on Volume/Expression	6F	
		21	1	00 - 7F	Receive Assignable Switch 2 Receive Assignable Switch 1 Receive Assignable Knob 2 Receive Assignable Knob 1 Receive RB Receive BC Receive FS	bit6: off, on ASW2 bit5: off, on ASW1 bit4: off, on AKN2 bit3: off, on AKN1 bit2: off, on RB bit1: off, on BC bit0: off, on FS	7F	
37	pp	22	1	00 - 01	Voice Element Pan	off, on	01	
		23	1	00 - 7F	AEG Attack Time	-64 - +63	40	
		24	1	00 - 7F	AEG Decay Time	-64 - +63	40	
		25	1	00 - 7F	AEG Sustain Level	-64 - +63	40	Only for Normal Voice
		26	1	00 - 7F	AEG Release Time	-64 - +63	40	Only for Normal Voice
		27	1	00 - 7F	FEG Attack Time	-64 - +63	40	Only for Normal Voice
		28	1	00 - 7F	FEG Decay Time	-64 - +63	40	Only for Normal Voice
		29	1	00 - 7F	FEG Sustain Level	-64 - +63	40	Only for Normal Voice
		2A	1	00 - 7F	FEG Release Time	-64 - +63	40	Only for Normal Voice
		2B	1	00 - 7F	FEG Depth	-64 - +63	40	Only for Normal Voice
		2C	1		reserved			
		2D	1	00 - 7F	Filter Cutoff Frequency	-64 - +63	40	
		2E	1	00 - 7F	Filter Resonance/Width	-64 - +63	40	
37	pp	2F	1		reserved			

Address			Size	Data Range (HEX)	Parameter Name	Settings	Default (HEX)	Notes
High	Mid	Low						
		30	2	00-01 2E-36	Low Frequency	50.1 - 2.00k	00 36	
		32	1	20-60	Low Gain	-32 - +32 (-12.00db - +12.00db)	40	
		33	1		reserved			
		34	2	00-01 53-71	Mid Frequency	139.7 - 10.1k	01 0D	
		36	1	20-60	Mid Gain	-32 - +32 (-12.00db - +12.00db)	40	
		37	1	00-1F	Mid Q	0 - 31 (0.7 - 10.3)	00	
		38	2	01-01 03-7F	High Frequency	503.8 - 14k	01 67	
		3A	1	20-60	High Gain	-32 - +32 (-12.00db - +12.00db)	40	
		3B	1		reserved			
37	pp	3C	1	00-7F	Assignable Knob 1 Value	-64 - +63	40	
		3D	1	00-7F	Assignable Knob 2 Value	-64 - +63	40	

TOTAL SIZE = 62 3E (HEX)
pp = part number 00 - 0F

Address			Size	Data Range (HEX)	Parameter Name	Settings	Default (HEX)	Notes
High	Mid	Low						
38	pp	00	1	00-01	ARP Switch	off, on	00	
		01	1	00-01	ARP MIDI Out Switch	off, on	00	
		02	1	00-10	ARP Transmit Channel	1..16, kbd-ch	Part No.	
		03	1	00-01	ARP Play Only	off, on	00	
		04	1		reserved			
		05	1		reserved			
		06	1	00-01	ARP Loop	off, on	01	
		07	1	00-02	ARP Hold	sync-off, off, on	01	
		08	1	00-06	ARP Unit Multiply	50%, 66%, 75%, 100%, 133%, 150%, 200%	03	
		09	1	00-7F	ARP Note Limit Low	C-2..G8	00	
		0A	1	00-7F	ARP Note Limit High	C-2..G8	7F	
		0B	1	01-7F	ARP Velocity Limit Low	1 - 127	01	
		0C	1	01-7F	ARP Velocity Limit High	1 - 127	7F	
		0D	1	00-04	ARP Key Mode	sort, thru, direct, sort+direct, thru+direct	00	
		0E	1	00-01	ARP Velocity Mode	original, thru	00	
		0F	1	00-01	ARP Change Timing	realtime, measure	01	
		10	1	01-07	ARP Quantize Value	32th, 16th_Triplet, 16th, 8th_Triplet, 8th, 4th_Triplet, 4th	03	
		11	1	00-64	ARP Quantize Strength	0..100%	00	
		12	2	00-01 00-48	ARP Velocity Rate	0..200%	00 64	
		14	2	00-01 00-48	ARP Gate Time Rate	0..200%	00 64	
		16	1		reserved			
		17	1		reserved			
		18	1		reserved			
		19	1		reserved			
		1A	2	00-01 08-78	ARP Swing	-120 ... 0 ... +120	01 00	
		1C	1	00-7F	ARP Accent Velocity Threshold	off, 1 ... 127	40	
		1D	1	00-01	ARP Accent Start Quantize	off, on	01	
		1E	1	3D-43	ARP Octave Range	-3 ... 0 ... +3	40	
		1F	1	36-4A	ARP Output Octave Shift	-10 ... 0 ... +10	40	
		20	1	00-01	ARP Trigger Mode	gate, toggle	00	
		21	1	00-01	ARP Random SFX	off, on	01	
		22	1	00-01	ARP Random SFX Key on Control	off, on	01	
		23	1	00-7F	ARP Random SFX Velocity Offset	-64 ... 0 ... +63	40	
		24	2	00-01 1C-64	ARP Assign Velocity Rate Offset SF1	-100 ... 0 ... +100	01 00	
		26	2	00-01 1C-64	ARP Assign Gate Time Offset SF1	-100 ... 0 ... +100	01 00	
		28	2	00-01 1C-64	ARP Assign Velocity Rate Offset SF2	-100 ... 0 ... +100	01 00	
		2A	2	00-01 1C-64	ARP Assign Gate Time Offset SF2	-100 ... 0 ... +100	01 00	
		2C	2	00-01 1C-64	ARP Assign Velocity Rate Offset SF3	-100 ... 0 ... +100	01 00	
		2E	2	00-01 1C-64	ARP Assign Gate Time Offset SF3	-100 ... 0 ... +100	01 00	
		30	2	00-01 1C-64	ARP Assign Velocity Rate Offset SF4	-100 ... 0 ... +100	01 00	
		32	2	00-01 1C-64	ARP Assign Gate Time Offset SF4	-100 ... 0 ... +100	01 00	
		34	2	00-01 1C-64	ARP Assign Velocity Rate Offset SF5	-100 ... 0 ... +100	01 00	
		36	2	00-01 1C-64	ARP Assign Gate Time Offset SF5	-100 ... 0 ... +100	01 00	

Address			Size	Data Range (HEX)	Parameter Name	Settings	Default (HEX)	Notes
High	Mid	Low						
		38	2	00-01 1C-64	ARP Assign Velocity Rate Offset SF6	-100 ... 0 ... +100	01 00	
		3A	2	00-01 1C-64	ARP Assign Gate Time Offset SF6	-100 ... 0 ... +100	01 00	
		3C	2	00-34 00-7B 40-41 00-7F	ARP SF1 Assign Type	off, Preset 0001 ... 6779, User 001 ... 256	04 6E	MA_Pf Arp1
		3E	2	00-34 00-7B 40-41 00-7F	ARP SF2 Assign Type	off, Preset 0001 ... 6779, User 001 ... 256	00 00	off
		40	2	00-34 00-7B 40-41 00-7F	ARP SF3 Assign Type	off, Preset 0001 ... 6779, User 001 ... 256	00 00	off
		42	2	00-34 00-7B 40-41 00-7F	ARP SF4 Assign Type	off, Preset 0001 ... 6779, User 001 ... 256	00 00	off
		44	2	00-34 00-7B 40-41 00-7F	ARP SF5 Assign Type	off, Preset 0001 ... 6779, User 001 ... 256	00 00	off
		46	2	00-34 00-7B 40-41 00-7F	ARP SF6 Assign Type	off, Preset 0001 ... 6779, User 001 ... 256	00 00	off

TOTAL SIZE = 72 48 (HEX)
pp = part number 00 - 0F

Address			Size	Data Range (HEX)	Parameter Name	Settings	Default (HEX)	Notes
High	Mid	Low						
39	4n	00	1	00-03	Audio Input Mode	L mono, R mono, L+R mono, stereo	03	Audio In Part (A/D)
		01	1	00-7F	Audio Input Part Volume	0 - 127	64	
		02	1	01-7F	Audio Input Part Pan	L63 - C - R63	40	
		03	1	00-7F	Audio Input Part Reverb Send	0 - 127	0C	
		04	1	00-7F	Audio Input Part Chorus Send	0 - 127	00	
		05	1		reserved			
		06	1	00-7F	Audio Input Part Dry Level	0 - 127	7F	
		07	1		reserved			

TOTAL SIZE = 8 08 (HEX)
pp = part number 00 - 00

MIDI PARAMETER CHANGE TABLE (NORMAL VOICE COMMON)

Address			Size	Data Range (HEX)	Parameter Name	Settings	Default (HEX)	Notes
High	Mid	Low						
40	00	00	1	00, 20 - 7E	Voice Name 1	32..126 (ASCII)	l	
		01	1	00, 20 - 7E	Voice Name 2	32..126 (ASCII)	n	
		02	1	00, 20 - 7E	Voice Name 3	32..126 (ASCII)	i	
		03	1	00, 20 - 7E	Voice Name 4	32..126 (ASCII)	t	
		04	1	00, 20 - 7E	Voice Name 5	32..126 (ASCII)	j	
		05	1	00, 20 - 7E	Voice Name 6	32..126 (ASCII)	a	
		06	1	00, 20 - 7E	Voice Name 7	32..126 (ASCII)	l	
		07	1	00, 20 - 7E	Voice Name 8	32..126 (ASCII)	i	
		08	1	00, 20 - 7E	Voice Name 9	32..126 (ASCII)	z	
		09	1	00, 20 - 7E	Voice Name 10	32..126 (ASCII)	e	
		0A	1	00, 20 - 7E	Voice Name 11	32..126 (ASCII)	d	
		0B	1	00, 20 - 7E	Voice Name 12	32..126 (ASCII)		
		0C	1	00, 20 - 7E	Voice Name 13	32..126 (ASCII)	V	
		0D	1	00, 20 - 7E	Voice Name 14	32..126 (ASCII)	o	
		0E	1	00, 20 - 7E	Voice Name 15	32..126 (ASCII)	i	
		0F	1	00, 20 - 7E	Voice Name 16	32..126 (ASCII)	c	
		10	1	00, 20 - 7E	Voice Name 17	32..126 (ASCII)	e	
		11	1	00, 20 - 7E	Voice Name 18	32..126 (ASCII)		
		12	1	00, 20 - 7E	Voice Name 19	32..126 (ASCII)		
		13	1	00, 20 - 7E	Voice Name 20	32..126 (ASCII)		
		14	1		reserved			
		15	1		reserved			
		16	1		reserved			
		17	1		reserved			
		18	1	00 - 11	Voice Category (Main)	0..17	11 (NoAsg)	
		19	1	00 - 05	Voice Category (Sub)	0..5	00 (-)	
		1A	1		reserved			
		1B	1		reserved			
		1C	1		reserved			
		1D	1		reserved			
40	00	1E	1	00 - 22	Knob Function Select	bit0-3 KnobUp: 0=Tone1, 1=Tone2, 2=Tone3 bit4-7 KnobLo: 0=EQ, 1=Fx, 2=Arp	00	
		1F	1	01 - 7F	Pan	L63..C..R63	40	
		20	1	28 - 58	Note Shift	-24 - +24 [semitones]	40	
		21	1	00 - 7F	AEG Attack Time	-64..+63	40	
		22	1	00 - 7F	AEG Decay Time	-64..+63	40	
		23	1	00 - 7F	AEG Sustain Level	-64..+63	40	
		24	1	00 - 7F	AEG Release Time	-64..+63	40	
		25	1	00 - 7F	FEG Attack Time	-64..+63	40	
		26	1	00 - 7F	FEG Decay Time	-64..+63	40	
		27	1		reserved			
		28	1	00 - 7F	FEG Release Time	-64..+63	40	
		29	1	00 - 7F	FEG Depth	-64..+63	40	
		2A	1	00 - 7F	Cutoff Frequency	-64..+63	40	
		2B	1	00 - 7F	Resonance	-64..+63	40	
		2C	2	00 - 01 2E - 36	EQ Low Frequency	50.1 - 2.00k	00 36	
		2E	1	20 - 60	EQ Low Gain	-32 - +32 (-12.00db - +12.00db)	40	
		2F	1		reserved			
		30	2	00 - 01 53 - 71	EQ Mid Frequency	139.7 - 10.1k	01 0D	
		32	1	20 - 60	EQ Mid Gain	-32 - +32 (-12.00db - +12.00db)	40	
		33	1	00 - 1F	EQ Mid Q	0 - 31 (0.7 - 10.3)	00	
		34	2	01 - 01 03 - 7F	EQ High Frequency	503.8 - 14.0k	01 67	
		36	1	20 - 60	EQ High Gain	-32 - +32 (-12.00db - +12.00db)	40	
		37	1		reserved			
		38	1	00 - 7F	Assignable Knob 1 Value	-64..+63	40	
		39	1	00 - 7F	Assignable Knob 2 Value	-64..+63	40	
		3A	1	00 - 01	Assignable Function 1 Mode	momentary, latch	01	
		3B	1	00 - 01	Assignable Function 2 Mode	momentary, latch	01	
		3C	1		reserved			
		3D	1		reserved			
		3E	1		reserved			
40	00	3F	1	00 - 7F	Volume	0 - 127	7F	
		40	1	00 - 01	Key Assign Mode	single, multi	01	
		41	1	00 - 01	Mono/Poly Mode	mono, poly	01	
		42	1	00 - 0C	Micro Tuning Scale	Equal, PureMajor, PureMinor, Werckmeister, Kirnberger, Vallot&Yng, 1/4Shift, 1/4Tone, 1/8Tone, Indian, Arabic1, Arabic2, Arabic3	00	
		43	1	00 - 0B	Micro Tuning Root	C - B	00	
		44	1	10 - 58	Pitch Bend Range Upper	-48 - +24 [semitones]	42	
		45	1	10 - 58	Pitch Bend Range Lower	-48 - +24 [semitones]	3E	

Address			Size	Data Range (HEX)	Parameter Name	Settings	Default (HEX)	Notes
High	Mid	Low						
		46	1	00 - 01	Portamento Mode	fingered, fulltime	01	
		47	1	00 - 01	Portamento Switch	off, on	00	
		48	1	00 - 7F	Portamento Time	0 - 127	40	
		49	1	00 - 03	Portamento Time Mode	rate1, time1, rate2, time2	00	
		4A	1	00 - 07	Legato Slope	0-7	00	
		4B	1	00 - 7F	Reverb Send	0 - 127	0C	
		4C	1	00 - 7F	Chorus Send	0 - 127	00	
40	00	4D	1	00 - 03	Insertion Connect Type	parallel, ins A>B, ins B>A, vocoder	01	
		4E	1		reserved			
		4F	1		reserved			

TOTAL SIZE = 80 50 (HEX)

Address			Size	Data Range (HEX)	Parameter Name	Settings	Default (HEX)	Notes
High	Mid	Low						
40	30	00	1	00 - 05	ARP SF Select	SF1 - SF6	00	
		01	1		reserved			
		02	2	00 - 02 05 - 2C	ARP Tempo	5..300	00 5A	
		04	1		reserved			
		05	1		reserved			
		06	2		reserved			
		08	2		reserved			
		0A	2		reserved			
		0C	2		reserved			
		0E	1	00 - 01	ARP Switch	off, on		
		0F	1		reserved			
		10	1		reserved			
		11	1		reserved			
		12	1		reserved			
		13	1		reserved			
		14	1	00 - 01	ARP Loop	off, on	01	
		15	1	00 - 02	ARP Hold	sync-off, off, on	01	
		16	1	00 - 06	ARP Unit Multiply	50%, 66%, 75%, 100%, 133%, 150%, 200%	03	
		17	1	00 - 7F	ARP Note Limit Low	C-2..G8	00	
		18	1	00 - 7F	ARP Note Limit High	C-2..G8	7F	
		19	1	01 - 7F	ARP Velocity Limit Low	1 - 127	01	
		1A	1	01 - 7F	ARP Velocity Limit High	1 - 127	7F	
		1B	1	00 - 04	ARP Key Mode	sort, thru, direct, sort+direct, thru+direct	00	
		1C	1	00 - 01	ARP Velocity Mode	original, thru	00	
		1D	1	00 - 01	ARP Change Timing	realtime, measure	01	
		1E	1	01 - 07	ARP Quantize Value	32th, 16th, Triplet, 16th, 8th, Triplet, 8th, 4th, Triplet, 4th	03	
		1F	1	00 - 64	ARP Quantize Strength	0...100%	00	
		20	2	00 - 01 00 - 48	ARP Velocity Rate	0...200%	00 64	
		22	2	00 - 01 00 - 48	ARP Gate Time Rate	0...200%	00 64	
		24	1		reserved			
		25	1		reserved			
		26	1		reserved			
		27	1		reserved			
		28	2	00 - 01 08 - 78	ARP Swing	-120 ... 0 ... +120	01 00	
		2A	1	00 - 7F	ARP Accent Velocity Threshold	off, 1 ... 127	40	
		2B	1	00 - 01	ARP Accent Start Quantize	off, on	01	
		2C	1	3D - 43	ARP Octave Range	-3 ... 0 ... +3	40	
		2D	1	36 - 4A	ARP Output Octave Shift	-10 ... 0 ... +10	40	
		2E	1	00 - 01	ARP Trigger Mode	gate, toggle	00	
		2F	1	00 - 01	ARP Random SFX	off, on	01	
		30	1	00 - 01	ARP Random SFX Key on Control	off, on	01	
		31	1	00 - 7F	ARP Random SFX Velocity Offset	-64 ... 0 ... +63	40	
		32	2	00 - 01 1C - 64	ARP Assign Velocity Rate Offset SF1	-100 ... 0 ... +100	01 00	
		34	2	00 - 01 1C - 64	ARP Assign Gate Time Offset SF1	-100 ... 0 ... +100	01 00	
		36	2	00 - 01 1C - 64	ARP Assign Velocity Rate Offset SF2	-100 ... 0 ... +100	01 00	
		38	2	00 - 01 1C - 64	ARP Assign Gate Time Offset SF2	-100 ... 0 ... +100	01 00	
		3A	2	00 - 01 1C - 64	ARP Assign Velocity Rate Offset SF3	-100 ... 0 ... +100	01 00	
		3C	2	00 - 01 1C - 64	ARP Assign Gate Time Offset SF3	-100 ... 0 ... +100	01 00	
		3E	2	00 - 01 1C - 64	ARP Assign Velocity Rate Offset SF4	-100 ... 0 ... +100	01 00	

Address			Size	Data Range (HEX)	Parameter Name	Settings	Default (HEX)	Notes
High	Mid	Low						
	40	2	00 - 01 1C - 64	ARP Assign Gate Time Offset SF4	-100 ... 0 ... +100	01 00		
	42	2	00 - 01 1C - 64	ARP Assign Velocity Rate Offset SF5	-100 ... 0 ... +100	01 00		
	44	2	00 - 01 1C - 64	ARP Assign Gate Time Offset SF5	-100 ... 0 ... +100	01 00		
	46	2	00 - 01 1C - 64	ARP Assign Velocity Rate Offset SF6	-100 ... 0 ... +100	01 00		
	48	2	00 - 01 1C - 64	ARP Assign Gate Time Offset SF6	-100 ... 0 ... +100	01 00		
	4A	2	00 - 34 00 - 7B 40 - 41 00 - 7F	ARP SF1 Assign Type	off, Preset 0001 ... 6779, User 001 ... 256	04 6E	MA_Pf Arp1	
	4C	2	00 - 34 00 - 7B 40 - 41 00 - 7F	ARP SF2 Assign Type	off, Preset 0001 ... 6779, User 001 ... 256	00 00	off	
	4E	2	00 - 34 00 - 7B 40 - 41 00 - 7F	ARP SF3 Assign Type	off, Preset 0001 ... 6779, User 001 ... 256	00 00	off	
	50	2	00 - 34 00 - 7B 40 - 41 00 - 7F	ARP SF4 Assign Type	off, Preset 0001 ... 6779, User 001 ... 256	00 00	off	
	52	2	00 - 34 00 - 7B 40 - 41 00 - 7F	ARP SF5 Assign Type	off, Preset 0001 ... 6779, User 001 ... 256	00 00	off	
	54	2	00 - 34 00 - 7B 40 - 41 00 - 7F	ARP SF6 Assign Type	off, Preset 0001 ... 6779, User 001 ... 256	00 00	off	

TOTAL SIZE = 86 56 (HEX)

Address			Size	Data Range (HEX)	Parameter Name	Settings	Default (HEX)	Notes
High	Mid	Low						
40	01	00	2	00 - 7F 00 - 7F	Reverb Type	Refer to the "Effect Type List."	01 00	Rev-X Hall
	02	1	00 - 7F	Preset Number		00	Basic	
	03	1		reserved				
	04	2	00 - 7F 00 - 7F	Reverb Parameter 1	Refer to the "Effect Parameter List."		Init value for Rev-X Hall / Basic	
	06	2	00 - 7F 00 - 7F	Reverb Parameter 2	:		Init value for Rev-X Hall / Basic	
	08	2	00 - 7F 00 - 7F	Reverb Parameter 3	:		Init value for Rev-X Hall / Basic	
	0A	2	00 - 7F 00 - 7F	Reverb Parameter 4	:		Init value for Rev-X Hall / Basic	
	0C	2	00 - 7F 00 - 7F	Reverb Parameter 5	:		Init value for Rev-X Hall / Basic	
	0E	2	00 - 7F 00 - 7F	Reverb Parameter 6	:		Init value for Rev-X Hall / Basic	
	10	2	00 - 7F 00 - 7F	Reverb Parameter 7	:		Init value for Rev-X Hall / Basic	
	12	2	00 - 7F 00 - 7F	Reverb Parameter 8	:		Init value for Rev-X Hall / Basic	
	14	2	00 - 7F 00 - 7F	Reverb Parameter 9	:		Init value for Rev-X Hall / Basic	
	16	2	00 - 7F 00 - 7F	Reverb Parameter 10	:		Init value for Rev-X Hall / Basic	
	18	2	00 - 7F 00 - 7F	Reverb Parameter 11	:		Init value for Rev-X Hall / Basic	
	1A	2	00 - 7F 00 - 7F	Reverb Parameter 12	:		Init value for Rev-X Hall / Basic	
	1C	2	00 - 7F 00 - 7F	Reverb Parameter 13	:		Init value for Rev-X Hall / Basic	
	1E	2	00 - 7F 00 - 7F	Reverb Parameter 14	:		Init value for Rev-X Hall / Basic	
	20	2	00 - 7F 00 - 7F	Reverb Parameter 15	:		Init value for Rev-X Hall / Basic	
	22	2	00 - 7F 00 - 7F	Reverb Parameter 16	:		Init value for Rev-X Hall / Basic	
	24	1	00 - 7F	Reverb Return	~>>dB...0dB...+6dB (0...96...127)	40		
	25	1	01 - 7F	Reverb Pan	L63...C...R63	40		

TOTAL SIZE = 38 26 (HEX)

Address			Size	Data Range (HEX)	Parameter Name	Settings	Default (HEX)	Notes
High	Mid	Low						
40	02	00	2	00 - 7F 00 - 7F	Chorus Type	Refer to the "Effect Type List."	03 00	G Chorus
	02	1	00 - 7F	Preset Number		00	Basic	
	03	1		reserved				
	04	2	00 - 7F 00 - 7F	Chorus Parameter 1	Refer to the "Effect Parameter List."		Init value for G Chorus / Basic	
	06	2	00 - 7F 00 - 7F	Chorus Parameter 2	:		Init value for G Chorus / Basic	
	08	2	00 - 7F 00 - 7F	Chorus Parameter 3	:		Init value for G Chorus / Basic	
	0A	2	00 - 7F 00 - 7F	Chorus Parameter 4	:		Init value for G Chorus / Basic	
	0C	2	00 - 7F 00 - 7F	Chorus Parameter 5	:		Init value for G Chorus / Basic	
	0E	2	00 - 7F 00 - 7F	Chorus Parameter 6	:		Init value for G Chorus / Basic	
	10	2	00 - 7F 00 - 7F	Chorus Parameter 7	:		Init value for G Chorus / Basic	
	12	2	00 - 7F 00 - 7F	Chorus Parameter 8	:		Init value for G Chorus / Basic	
	14	2	00 - 7F 00 - 7F	Chorus Parameter 9	:		Init value for G Chorus / Basic	
	16	2	00 - 7F 00 - 7F	Chorus Parameter 10	:		Init value for G Chorus / Basic	
	18	2	00 - 7F 00 - 7F	Chorus Parameter 11	:		Init value for G Chorus / Basic	
	1A	2	00 - 7F 00 - 7F	Chorus Parameter 12	:		Init value for G Chorus / Basic	
	1C	2	00 - 7F 00 - 7F	Chorus Parameter 13	:		Init value for G Chorus / Basic	
	1E	2	00 - 7F 00 - 7F	Chorus Parameter 14	:		Init value for G Chorus / Basic	
	20	2	00 - 7F 00 - 7F	Chorus Parameter 15	:		Init value for G Chorus / Basic	
	22	2	00 - 7F 00 - 7F	Chorus Parameter 16	:		Init value for G Chorus / Basic	
	24	1	00 - 7F	Chorus Return	~>>dB...0dB...+6dB (0...96...127)	60		
	25	1	01 - 7F	Chorus Pan	L63...C...R63	40		
	26	1	00 - 7F	Send Chorus To Reverb	~>>dB...0dB (0...127)	00		
	27	1		reserved				

TOTAL SIZE = 40 28 (HEX)

Address			Size	Data Range (HEX)	Parameter Name	Settings	Default (HEX)	Notes
High	Mid	Low						
40	03	00	2	00 - 7F 00 - 7F	Insertion A Type	Refer to the "Effect Type List."	00 00	
	02	1	00 - 7F	Preset Number		00		
	03	1		reserved				
	04	2	00 - 7F 00 - 7F	Insertion A Parameter 1	Refer to the "Effect Parameter List."	00 00		
	06	2	00 - 7F 00 - 7F	Insertion A Parameter 2	:	00 00		
	08	2	00 - 7F 00 - 7F	Insertion A Parameter 3	:	00 00		
	0A	2	00 - 7F 00 - 7F	Insertion A Parameter 4	:	00 00		
	0C	2	00 - 7F 00 - 7F	Insertion A Parameter 5	:	00 00		
	0E	2	00 - 7F 00 - 7F	Insertion A Parameter 6	:	00 00		
	10	2	00 - 7F 00 - 7F	Insertion A Parameter 7	:	00 00		
	12	2	00 - 7F 00 - 7F	Insertion A Parameter 8	:	00 00		
	14	2	00 - 7F 00 - 7F	Insertion A Parameter 9	:	00 00		
	16	2	00 - 7F 00 - 7F	Insertion A Parameter 10	:	00 00		
	18	2	00 - 7F 00 - 7F	Insertion A Parameter 11	:	00 00		
	1A	2	00 - 7F 00 - 7F	Insertion A Parameter 12	:	00 00		
	1C	2	00 - 7F 00 - 7F	Insertion A Parameter 13	:	00 00		
	1E	2	00 - 7F 00 - 7F	Insertion A Parameter 14	:	00 00		
	20	2	00 - 7F 00 - 7F	Insertion A Parameter 15	:	00 00		
	22	2	00 - 7F 00 - 7F	Insertion A Parameter 16	:	00 00		

TOTAL SIZE = 36 24 (HEX)

Address			Size	Data Range (HEX)	Parameter Name	Settings	Default (HEX)	Notes
High	Mid	Low						
40	04	00	2	00 - 7F 00 - 7F	Insertion B Type	Refer to the "Effect Type List."	00 00	For A/D Part
		02	1	00 - 7F	Preset Number		00	
		03	1		reserved			
		04	2	00 - 7F 00 - 7F	Insertion B Parameter 1	Refer to the "Effect Parameter List."	00 00	
		06	2	00 - 7F 00 - 7F	Insertion B Parameter 2	:	00 00	
		08	2	00 - 7F 00 - 7F	Insertion B Parameter 3	:	00 00	
		0A	2	00 - 7F 00 - 7F	Insertion B Parameter 4	:	00 00	
		0C	2	00 - 7F 00 - 7F	Insertion B Parameter 5	:	00 00	
		0E	2	00 - 7F 00 - 7F	Insertion B Parameter 6	:	00 00	
		10	2	00 - 7F 00 - 7F	Insertion B Parameter 7	:	00 00	
		12	2	00 - 7F 00 - 7F	Insertion B Parameter 8	:	00 00	
		14	2	00 - 7F 00 - 7F	Insertion B Parameter 9	:	00 00	
		16	2	00 - 7F 00 - 7F	Insertion B Parameter 10	:	00 00	
		18	2	00 - 7F 00 - 7F	Insertion B Parameter 11	:	00 00	
		1A	2	00 - 7F 00 - 7F	Insertion B Parameter 12	:	00 00	
		1C	2	00 - 7F 00 - 7F	Insertion B Parameter 13	:	00 00	
		1E	2	00 - 7F 00 - 7F	Insertion B Parameter 14	:	00 00	
		20	2	00 - 7F 00 - 7F	Insertion B Parameter 15	:	00 00	
		22	2	00 - 7F 00 - 7F	Insertion B Parameter 16	:	00 00	

TOTAL SIZE = 36 24 (HEX)

Address			Size	Data Range (HEX)	Parameter Name	Settings	Default (HEX)	Notes
High	Mid	Low						
40	05	00	2	00 - 7F 00 - 7F	Insertion L Type	Refer to the "Effect Type List."	00 00	
		02	1	00 - 7F	Preset Number		00	
		03	1		reserved			
		04	2	00 - 7F 00 - 7F	Insertion L Parameter 1	Refer to the "Effect Parameter List."	00 00	
		06	2	00 - 7F 00 - 7F	Insertion L Parameter 2	:	00 00	
		08	2	00 - 7F 00 - 7F	Insertion L Parameter 3	:	00 00	
		0A	2	00 - 7F 00 - 7F	Insertion L Parameter 4	:	00 00	
		0C	2	00 - 7F 00 - 7F	Insertion L Parameter 5	:	00 00	
		0E	2	00 - 7F 00 - 7F	Insertion L Parameter 6	:	00 00	
		10	2	00 - 7F 00 - 7F	Insertion L Parameter 7	:	00 00	
		12	2	00 - 7F 00 - 7F	Insertion L Parameter 8	:	00 00	
		14	2	00 - 7F 00 - 7F	Insertion L Parameter 9	:	00 00	
		16	2	00 - 7F 00 - 7F	Insertion L Parameter 10	:	00 00	
		18	2	00 - 7F 00 - 7F	Insertion L Parameter 11	:	00 00	
		1A	2	00 - 7F 00 - 7F	Insertion L Parameter 12	:	00 00	
		1C	2	00 - 7F 00 - 7F	Insertion L Parameter 13	:	00 00	
		1E	2	00 - 7F 00 - 7F	Insertion L Parameter 14	:	00 00	
		20	2	00 - 7F 00 - 7F	Insertion L Parameter 15	:	00 00	
		22	2	00 - 7F 00 - 7F	Insertion L Parameter 16	:	00 00	
		24	2	00 - 7F 00 - 7F	Insertion L Parameter 17	:	00 00	
		26	2	00 - 7F 00 - 7F	Insertion L Parameter 18	:	00 00	
		28	2	00 - 7F 00 - 7F	Insertion L Parameter 19	:	00 00	
		2A	2	00 - 7F 00 - 7F	Insertion L Parameter 20	:	00 00	
		2C	2	00 - 7F 00 - 7F	Insertion L Parameter 21	:	00 00	
		2E	2	00 - 7F 00 - 7F	Insertion L Parameter 22	:	00 00	
		30	2	00 - 7F 00 - 7F	Insertion L Parameter 23	:	00 00	
		32	2	00 - 7F 00 - 7F	Insertion L Parameter 24	:	00 00	

Address			Size	Data Range (HEX)	Parameter Name	Settings	Default (HEX)	Notes
High	Mid	Low						
		34	2	00 - 7F 00 - 7F	Insertion L Parameter 25	:	00 00	
		36	2	00 - 7F 00 - 7F	Insertion L Parameter 26	:	00 00	
		38	2	00 - 7F 00 - 7F	Insertion L Parameter 27	:	00 00	
		3A	2	00 - 7F 00 - 7F	Insertion L Parameter 28	:	00 00	
		3C	2	00 - 7F 00 - 7F	Insertion L Parameter 29	:	00 00	
		3E	2	00 - 7F 00 - 7F	Insertion L Parameter 30	:	00 00	
		40	2	00 - 7F 00 - 7F	Insertion L Parameter 31	:	00 00	
		42	2	00 - 7F 00 - 7F	Insertion L Parameter 32	:	00 00	

TOTAL SIZE = 68 44 (HEX)

Address			Size	Data Range (HEX)	Parameter Name	Settings	Default (HEX)	Notes
High	Mid	Low						
40	06	00	1	00 - 7F	Controller Set 1 Depth	-64 - +63	40	
		01	1	00 - 0E	Controller Set 1 Source	0: PB, 1: MW, 3: AT, 4: FC, 5: FS, 6: RB, 7: BC, 8: AKN1, 9: AKN2, 12: FC2, 13: ASW1, 14: ASW2	01	
		02	2	00 - 00 00 - 65	Controller Set 1 Destination	0 - 101	00 00	
		04	1	00 - 7F	Controller Set 2 Depth	-64 - +63	40	
		05	1	00 - 0E	Controller Set 2 Source	0: PB, 1: MW, 3: AT, 4: FC, 5: FS, 6: RB, 7: BC, 8: AKN1, 9: AKN2, 12: FC2, 13: ASW1, 14: ASW2	01	
		06	2	00 - 00 00 - 65	Controller Set 2 Destination	0 - 101	00 00	
		08	1	00 - 7F	Controller Set 3 Depth	-64 - +63	40	
		09	1	00 - 0E	Controller Set 3 Source	0: PB, 1: MW, 3: AT, 4: FC, 5: FS, 6: RB, 7: BC, 8: AKN1, 9: AKN2, 12: FC2, 13: ASW1, 14: ASW2	01	
		0A	2	00 - 00 00 - 65	Controller Set 3 Destination	0 - 101	00 00	
		0C	1	00 - 7F	Controller Set 4 Depth	-64 - +63	40	
		0D	1	00 - 0E	Controller Set 4 Source	0: PB, 1: MW, 3: AT, 4: FC, 5: FS, 6: RB, 7: BC, 8: AKN1, 9: AKN2, 12: FC2, 13: ASW1, 14: ASW2	08	
		0E	2	00 - 00 00 - 65	Controller Set 4 Destination	0 - 101	00 00	
		10	1	00 - 7F	Controller Set 5 Depth	-64 - +63	40	
		11	1	00 - 0E	Controller Set 5 Source	0: PB, 1: MW, 3: AT, 4: FC, 5: FS, 6: RB, 7: BC, 8: AKN1, 9: AKN2, 12: FC2, 13: ASW1, 14: ASW2	09	
		12	2	00 - 00 00 - 65	Controller Set 5 Destination	0 - 101	00 00	
		14	1	00 - 7F	Controller Set 6 Depth	-64 - +63	40	
		15	1	00 - 0E	Controller Set 6 Source	0: PB, 1: MW, 3: AT, 4: FC, 5: FS, 6: RB, 7: BC, 8: AKN1, 9: AKN2, 12: FC2, 13: ASW1, 14: ASW2	03	
		16	2	00 - 00 00 - 65	Controller Set 6 Destination	0 - 101	00 00	
40	06	18	1	00 - 05	LFO Phase	0, 90, 120, 180, 240, 270	00	
		19	1	00 - 0C	LFO Wave	tri, tri+, sawup, sawdwn, squ1/4, squ1/3, squ, squ2/3, squ3/4, trpzd, S/H1, S/H2, user	00	
		1A	1	00 - 3F	LFO Speed	0 - 63	20	This is available only when Tempo Sync is set to off.
		1B	1	05 - 18	LFO Tempo Speed	16th, 8th/3, 16th., 8th, 4th/3, 8th., 4th, 2th/3, 4th., 2nd, Whole/3, 2nd., 4thX4, 4thX5, 4thX6, 4thX7, 4thX8, 4thX16, 4thX32, 4thX64	0B	This is available only when Tempo Sync is set to off.
		1C	1	00 - 01	LFO Tempo Sync	off, on	00	
		1D	1	00 - 7F	LFO Delay Time	0 - 127	00	
		1E	1	00 - 7F	LFO Fade In Time	0 - 127	00	
		1F	1	00 - 7F	LFO Hold Time	0 - 126, hold	7F	
		20	1	00 - 7F	LFO Fade Out Time	0 - 127	40	
		21	1	00 - 02	LFO Key On Reset	off, each-on, 1st-on	02	
		22	1	00 - 01	LFO Play Mode	loop, one shop	00	
		23	1	00 - 7F	LFO Set 1 Depth	0 - 127	00	

MIDI PARAMETER CHANGE TABLE (NORMAL VOICE ELEMENT)

Address			Size	Data Range (HEX)	Parameter Name	Settings	Default (HEX)	Notes
High	Mid	Low						
		24	1	00 - 45	LFO Set 1 Destination	Refer to the "LFO Box Destination" of the Control List.	02	
		25	1	00 - 7F	LFO Set 2 Depth	0 - 127	00	
		26	1	00 - 45	LFO Set 2 Destination	Refer to the "LFO Box Destination" of the Control List.	04	
		27	1	00 - 7F	LFO Set 3 Depth	0 - 127	00	
		28	1	00 - 45	LFO Set 3 Destination	Refer to the "LFO Box Destination" of the Control List.	04	
		29	1	00 - 06	User Wave Total Step	2, 3, 4, 6, 8, 12, 16	06	
		2A	1	00 - 03	User Wave Slope	off, up, down, up&down	00	
		2B	1	00 - 7F	User Wave Step Value 1	0 - 127	40	
		2C	1	00 - 7F	User Wave Step Value 2	0 - 127	40	
		2D	1	00 - 7F	User Wave Step Value 3	0 - 127	40	
		2E	1	00 - 7F	User Wave Step Value 4	0 - 127	40	
		2F	1	00 - 7F	User Wave Step Value 5	0 - 127	40	
		30	1	00 - 7F	User Wave Step Value 6	0 - 127	40	
		31	1	00 - 7F	User Wave Step Value 7	0 - 127	40	
		32	1	00 - 7F	User Wave Step Value 8	0 - 127	40	
		33	1	00 - 7F	User Wave Step Value 9	0 - 127	40	
		34	1	00 - 7F	User Wave Step Value 10	0 - 127	40	
		35	1	00 - 7F	User Wave Step Value 11	0 - 127	40	
		36	1	00 - 7F	User Wave Step Value 12	0 - 127	40	
		37	1	00 - 7F	User Wave Step Value 13	0 - 127	40	
		38	1	00 - 7F	User Wave Step Value 14	0 - 127	40	
		39	1	00 - 7F	User Wave Step Value 15	0 - 127	40	
		3A	1	00 - 7F	User Wave Step Value 16	0 - 127	40	
		3B	1	00 - 7F	LFO Random Speed Depth	0 - 127	00	

TOTAL SIZE = 60 3C (HEX)

Address			Size	Data Range (HEX)	Parameter Name	Settings	Default (HEX)	Notes
High	Mid	Low						
41	ee	00	1	00 - 01	Element Switch	off, on	01 (only EL1)	
		01	1		reserved			
		02	2	00 - 14 01 - 6E	Wave Number	1 - 2670	00 01	
		04	1	00 - 07	Element Group Number	1 - 8	00	
		05	1	01 - 7F	Pan	L63 - C - R63	40	
		06	1	00 - 7F	Random Pan Depth	0 - 127	00	
		07	1	00 - 7F	Alternate Pan Depth	L64 - 0 - R63	40	
		08	1	00 - 7F	Scaling Pan Depth	-64 - +63	40	
		09	1	00 - 07	XA Control	normal, legato, key off sound, wave cycle, wave random, all AF off, AF 1 on, AF 2 on	00	
		0A	1	00 - 7F	Note Limit Low	0 - 127	00	
		0B	1	00 - 7F	Note Limit High	0 - 127	7F	
		0C	1	01 - 7F	Velocity Limit Low	1 - 127	01	
		0D	1	01 - 7F	Velocity Limit High	1 - 127	7F	
		0E	1	00 - 7F	Velocity Cross Fade	0 - 127	00	
		0F	1	00 - 7F	Key On Delay	0 - 127 (available only when the Tempo Sync is set to off.)	00	
		10	1	00 - 01	Key On Delay Tempo Sync	off, on	00	
		11	1	00 - 02	Insertion Effect	thru, insA, insB	01	
		12	2	00 - 00 00 - 3F	Controller Set Element Sw	1st bit6-0: reserved 2nd bit6: reserved 2nd bit5: off, on set 6 2nd bit4: off, on set 5 2nd bit3: off, on set 4 2nd bit2: off, on set 3 2nd bit1: off, on set 2 2nd bit0: off, on set 1	00 3F	
		14	2	00 - 00 00 - 07	LFO Set Element Sw	1st bit6-0: reserved 2nd bit6-3: reserved 2nd bit2: off, on box 3 2nd bit1: off, on box 2 2nd bit0: off, on set 1	00 07	
		16	1	05 - 15	Key On Delay Tempo	16th, 8th/3, 16th., 8th, 4th/3, 8th., 4th, 2th/3, 4th., 2nd, Whole/3, 2nd., 4thX4, 4thX5, 4thX6, 4thX7, 4thX8	0B	This is available only when Tempo Sync is set to off.
		17	1	00 - 01	Half Damper Switch	off, on	00	
		18	1		reserved			
		19	1		reserved			
41	ee	1A	1	00 - 7F	Element Level	0 - 127	7F	
		1B	1	00 - 7F	Level Velocity Sensitivity	-64 - +63	40	
		1C	1	00 - 7F	Level Velocity Sensitivity Offset	0 - 127	00	
		1D	1	00 - 04	Level Velocity Sensitivity Curve	00 - 04 □□□□	03	
		1E	1	00 - 7F	AEG Attack Time	0 - 127	00	
		1F	1	00 - 7F	AEG Decay 1 Time	0 - 127	40	
		20	1	00 - 7F	AEG Decay 2 Time	0 - 127	40	
		21	1	00 - 7F	Half Damper Time	0 - 127	7F	
		22	1	00 - 7F	AEG Release Time	0 - 127	32	
		23	1	00 - 7F	AEG Init Level	0 - 127	00	
		24	1	00 - 7F	AEG Attack Level	0 - 127	7F	
		25	1	00 - 7F	AEG Decay 1 Level	0 - 127	7F	
		26	1	00 - 7F	AEG Decay 2 Level	0 - 127	7F	
		27	1		reserved			
		28	1	00 - 04	AEG Time Velocity Segment	ATK, ATK+DCY, DCY, ATK+RLS, ALL	04	
		29	1	00 - 7F	AEG Time Velocity Sensitivity	-64 - +63	40	
		2A	1	00 - 7F	AEG Time Key Follow Sensitivity	-64 - +63	40	
		2B	1	00 - 7F	AEG Time Key Follow Center Key	C -2 - G8	18	
		2C	1	00 - 7C	Level Scaling Break Point 1	C -2 - E8	24	BP1<BP2<BP3<BP4
		2D	1	01 - 7D	Level Scaling Break Point 2	C#2 - F8	30	BP1<BP2<BP3<BP4
		2E	1	02 - 7E	Level Scaling Break Point 3	D -2 - F#8	3C	BP1<BP2<BP3<BP4
		2F	1	03 - 7F	Level Scaling Break Point 4	D#2 - G8	48	BP1<BP2<BP3<BP4
		30	2	00 - 01 00 - 7F	Level Scaling Offset 1	-128 - +127	01 00	
		32	2	00 - 01 00 - 7F	Level Scaling Offset 2	-128 - +127	01 00	
		34	2	00 - 01 00 - 7F	Level Scaling Offset 3	-128 - +127	01 00	
		36	2	00 - 01 00 - 7F	Level Scaling Offset 4	-128 - +127	01 00	
		38	1	00 - 7F	Level Key Follow Sensitivity	-200% - +200%	40	
		39	1	00 - 7F	AEG Time Key Follow Sensitivity Release Adjustment	-64 - +63	40	
		3A	1	10 - 70	Coarse Tune	-48 - +48	40	
		3B	1	00 - 7F	Fine Tune	-64 - +63	40	
		3C	1	00 - 7F	Pitch Velocity Sensitivity	-64 - +63	40	

Address			Size	Data Range (HEX)	Parameter Name	Settings	Default (HEX)	Notes
High	Mid	Low						
		3D	1	00 - 7F	Random Pitch Depth	0 - 127	00	
		3E	1	00 - 7F	Pitch Key Follow Sensitivity	-200% - +200%	60	
		3F	1	00 - 7F	Pitch Key Follow Sensitivity Center Key	C-2 - G8	3C	
		40	1	00 - 7F	Pitch Fine Scaling Sensitivity	-64 - +63	40	
		41	1	00 - 7F	PEG Hold Time	0 - 127	00	
		42	1	00 - 7F	PEG Attack Time	0 - 127	28	
		43	1	00 - 7F	PEG Decay 1 Time	0 - 127	40	
		44	1	00 - 7F	PEG Decay 2 Time	0 - 127	40	
		45	1	00 - 7F	PEG Release Time	0 - 127	40	
		46	2	00 - 01 00 - 7F	PEG Hold Level	-128 - +127 (-4800 - +4800 [cent])	01 00	
		48	2	00 - 01 00 - 7F	PEG Attack Level	-128 - +127 (-4800 - +4800 [cent])	01 00	
		4A	2	00 - 01 00 - 7F	PEG Decay 1 Level	-128 - +127 (-4800 - +4800 [cent])	01 00	
		4C	2	00 - 01 00 - 7F	PEG Decay 2 Level	-128 - +127 (-4800 - +4800 [cent])	01 00	
		4E	2	00 - 01 00 - 7F	PEG Release Level	-128 - +127 (-4800 - +4800 [cent])	01 00	
		50	1	00 - 7F	PEG Depth	-64 - +63	54	
		51	1	00 - 04	PEG Time Velocity Sensitivity Segment	ATK, ATK+DCY, DCY, ATK+RLS, ALL	04	
		52	1	00 - 7F	PEG Time Velocity Sensitivity	-64 - +63	40	
		53	1	00 - 7F	PEG Depth Velocity Sensitivity	-64 - +63	40	
		54	1	00 - 04	PEG Depth Velocity Sensitivity Curve	00 - 04 [0][0][0][0]	02	
		55	1	00 - 7F	PEG Time Key Follow Sensitivity	-64 - +63	40	
		56	1	00 - 7F	PEG Time Key Follow Sensitivity Center Key	C-2 - G8	3C	
		57	1		reserved			

TOTAL SIZE = 88 58 (HEX)
ee = element number 00 - 07

Address			Size	Data Range (HEX)	Parameter Name	Settings	Default (HEX)	Notes
High	Mid	Low						
42	ee	00	1	00 - 15	Filter Type	LPF24D, LPF24A, LPF18, LPF18s, LPF12+HPF12, LPF6+HPF12, HPF24D, HPF12, BPF12D, BPFw, BPF6, BEF12, BEF6, DualLPF, DualHPF, DualBPF, DualBEF, LPF12+BPF6, THRU	04	
		01	1		reserved			
		02	2	00 - 01 00 - 7F	Filter Cutoff Frequency	0 - 255	01 20	
		04	1	00 - 7F	Filter Cutoff Velocity Sensitivity	-64 - +63	40	
		05	1	00 - 7F	Filter Resonance/Width/ Band	0 - 127	00	
		06	1	00 - 7F	Filter Resonance Velocity Sensitivity	-64 - +63	40	
		07	1		reserved			
		08	2	00 - 01 00 - 7F	HPF Cutoff Frequency	0 - 255	00 00	
		0A	2	00 - 01 00 - 7F	Distance	-128 - +127 (available only when the dual type filter is set.)	01 00	
		0C	2	00 - 01 00 - 7F	Filter Gain	0 - 255	01 66	
		0E	1	00 - 7F	FEG Hold Time	0 - 127	00	
		0F	1	00 - 7F	FEG Attack Time	0 - 127	00	
		10	1	00 - 7F	FEG Decay 1 Time	0 - 127	40	
		11	1	00 - 7F	FEG Decay 2 Time	0 - 127	40	
		12	1	00 - 7F	FEG Release Time	0 - 127	50	
		13	1		reserved			
		14	2	00 - 01 00 - 7F	FEG Hold Level	-128 - +127 (-9600 - +9600 [cent])	01 00	
		16	2	00 - 01 00 - 7F	FEG Attack Level	-128 - +127 (-9600 - +9600 [cent])	01 7F	
		18	2	00 - 01 00 - 7F	FEG Decay 1 Level	-128 - +127 (-9600 - +9600 [cent])	01 7F	
		1A	2	00 - 01 00 - 7F	FEG Decay 2 Level	-128 - +127 (-9600 - +9600 [cent])	01 7F	
		1C	2	00 - 01 00 - 7F	FEG Release Level	-128 - +127 (-9600 - +9600 [cent])	01 00	
		1E	1	00 - 7F	FEG Depth	-64 - +63	68	
		1F	1	00 - 04	FEG Time Velocity Sensitivity Segment	ATK, ATK+DCY, DCY, ATK+RLS, ALL	04	
		20	1	00 - 7F	FEG Time Velocity Sensitivity	-64 - +63	40	
		21	1	00 - 7F	FEG Depth Velocity Sensitivity	-64 - +63	40	
		22	1	00 - 04	FEG Depth Velocity Sensitivity Curve	00 - 04 [0][0][0][0]	02	

Address			Size	Data Range (HEX)	Parameter Name	Settings	Default (HEX)	Notes
High	Mid	Low						
		23	1	00 - 7F	FEG Time Key Follow Sensitivity	-64 - +63	40	
		24	1	00 - 7F	FEG Time Key Follow Sensitivity Center Key	C-2 - G8	18	
		25	1	00 - 7C	Filter Cutoff Scaling Break Point 1	C-2 - E8	24	BP1<BP2<BP3<BP4
		26	1	01 - 7D	Filter Cutoff Scaling Break Point 2	C#-2 - F8	30	BP1<BP2<BP3<BP4
		27	1	02 - 7E	Filter Cutoff Scaling Break Point 3	D-2 - F#8	3C	BP1<BP2<BP3<BP4
		28	1	03 - 7F	Filter Cutoff Scaling Break Point 4	D#-2 - G8	48	BP1<BP2<BP3<BP4
		29	1		reserved			
		2A	2	00 - 01 00 - 7F	Filter Cutoff Scaling Offset 1	-128 - +127	01 00	
		2C	2	00 - 01 00 - 7F	Filter Cutoff Scaling Offset 2	-128 - +127	01 00	
		2E	2	00 - 01 00 - 7F	Filter Cutoff Scaling Offset 3	-128 - +127	01 00	
		30	2	00 - 01 00 - 7F	Filter Cutoff Scaling Offset 4	-128 - +127	01 00	
		32	1	00 - 7F	Filter Cutoff Key Follow Sensitivity	-200% - +200%	4A	
		33	1	00 - 7F	HPF Cutoff Key Follow Sensitivity	-200% - +200%	40	
42	ee	34	1	00 - 05	EQ Type	2 Band, P.EQ, Boost6, Boost12, Boost18, thru	00	
		35	1	00 - 1F	EQ Q	0 - 31 (0.7 - 10.3)	00	
		36	2	00 - 01 2E - 7B	EQ 1 Frequency	2 Band: 46 - 182, P.EQ: 83 - 251	00 36	
		38	1	20 - 60	EQ 1 Gain	-32 - +32	40	
		39	1		reserved			
		3A	2	01 - 01 03 - 71	EQ 2 Frequency	2 Band: 131 - 241	01 67	
		3C	1	20 - 60	EQ 2 Gain	-32 - +32	40	
		3D	1		reserved			
42	ee	3E	1	00 - 02	LFO Wave	saw, tri, squ	01	
		3F	1	00 - 01	LFO Key On Reset	off, on	01	
		40	1	00 - 7F	LFO Key On Delay Time	0 - 127	00	
		41	1	00 - 3F	LFO Speed	0 - 63	26	
		42	1	00 - 7F	LFO AMod Depth	0 - 127	00	
		43	1	00 - 7F	LFO PMod Depth	0 - 127	00	
		44	1	00 - 7F	LFO FMod Depth	0 - 127	00	
		45	1	00 - 7F	LFO Fade In Time	0 - 127	00	
42	ee	46	1	00 - 05	Common LFO Phase Offset	+0, +90, +120, +180, +240, +270	00	
		47	1	00 - 7F	Common LFO Box 1 Depth Ratio	0 - 127	7F	
		48	1	00 - 7F	Common LFO Box 2 Depth Ratio	0 - 127	7F	
		49	1	00 - 7F	Common LFO Box 3 Depth Ratio	0 - 127	7F	

TOTAL SIZE = 74 4A (HEX)
ee = element number 00 - 07

MIDI PARAMETER CHANGE TABLE (DRUM VOICE COMMON)

Address		Size	Data Range (HEX)	Parameter Name	Settings	Default (HEX)	Notes
High	Mid	Low					
46	00	00	1	00, 20 - 7E	Voice Name 1	32..126 (ASCII)	l
		01	1	00, 20 - 7E	Voice Name 2	32..126 (ASCII)	n
		02	1	00, 20 - 7E	Voice Name 3	32..126 (ASCII)	i
		03	1	00, 20 - 7E	Voice Name 4	32..126 (ASCII)	t
		04	1	00, 20 - 7E	Voice Name 5	32..126 (ASCII)	i
		05	1	00, 20 - 7E	Voice Name 6	32..126 (ASCII)	a
		06	1	00, 20 - 7E	Voice Name 7	32..126 (ASCII)	l
		07	1	00, 20 - 7E	Voice Name 8	32..126 (ASCII)	i
		08	1	00, 20 - 7E	Voice Name 9	32..126 (ASCII)	z
		09	1	00, 20 - 7E	Voice Name 10	32..126 (ASCII)	e
		0A	1	00, 20 - 7E	Voice Name 11	32..126 (ASCII)	d
		0B	1	00, 20 - 7E	Voice Name 12	32..126 (ASCII)	
		0C	1	00, 20 - 7E	Voice Name 13	32..126 (ASCII)	V
		0D	1	00, 20 - 7E	Voice Name 14	32..126 (ASCII)	o
		0E	1	00, 20 - 7E	Voice Name 15	32..126 (ASCII)	i
		0F	1	00, 20 - 7E	Voice Name 16	32..126 (ASCII)	c
		10	1	00, 20 - 7E	Voice Name 17	32..126 (ASCII)	e
		11	1	00, 20 - 7E	Voice Name 18	32..126 (ASCII)	
		12	1	00, 20 - 7E	Voice Name 19	32..126 (ASCII)	
		13	1	00, 20 - 7E	Voice Name 20	32..126 (ASCII)	
		14	1		reserved		
		15	1		reserved		
		16	1		reserved		
		17	1		reserved		
		18	1	00 - 11	Voice Category (Main)	0..17	11 (NoAsg) Refer to the Voice category list.
		19	1	00 - 05	Voice Category (Sub)	0..5	00 (-) Refer to the Voice category list.
		1A	1		reserved		
		1B	1		reserved		
		1C	1		reserved		
		1D	1		reserved		
46	00	1E	1	00 - 22	Knob Function Select	bit0-3 KnobUp: 0=Tone1, 1=Tone2, 2=Tone3 bit4-7 KnobLo: 0=EQ, 1=Fx, 2=Arp	00
		1F	1	01 - 7F	Pan	L63..C..R63	40
		20	1		reserved		
		21	1	00 - 7F	AEG Attack Time	-64..+63	40
		22	1	00 - 7F	AEG Decay Time	-64..+63	40
		23	1		reserved		
		24	1		reserved		
		25	1		reserved		
		26	1		reserved		
		27	1		reserved		
		28	1		reserved		
		29	1		reserved		
		2A	1	00 - 7F	Cutoff Frequency	-64..+63	40
		2B	1	00 - 7F	Resonance	-64..+63	40
		2C	2	00 - 01 2E - 36	EQ Low Frequency	50.1 - 2.00k	00 36
		2E	1	20 - 60	EQ Low Gain	-32 - +32 (-12.00db - +12.00db)	40
		2F	1		reserved		
		30	2	00 - 01 53 - 71	EQ Mid Frequency	139.7 - 10.1k	01 0D
		32	1	20 - 60	EQ Mid Gain	-32 - +32 (-12.00db - +12.00db)	40
		33	1	00 - 1F	EQ Mid Q	0 - 31 (0.7 - 10.3)	00
		34	2	01 - 01 03 - 7F	EQ High Frequency	503.8 - 14.0k	01 67
		36	1	20 - 60	EQ High Gain	-32 - +32 (-12.00db - +12.00db)	40
		37	1		reserved		
		38	1	00 - 7F	Assignable Knob 1 Value	-64..+63	40
		39	1	00 - 7F	Assignable Knob 2 Value	-64..+63	40
		3A	1	00 - 01	Assignable Function 1 Mode	momentary, latch	01
		3B	1	00 - 01	Assignable Function 2 Mode	momentary, latch	01
		3C	1		reserved		
		3D	1		reserved		
		3E	1		reserved		
46	00	3F	1	00 - 7F	Volume	0 - 127	7F
		40	1		reserved		
		41	1	10 - 58	Pitch Bend Range Upper	-48 - +24 [semitones]	42
		42	1	10 - 58	Pitch Bend Range Lower	-48 - +24 [semitones]	3E
		43	1	00 - 7F	Reverb Send	0 - 127	00
		44	1	00 - 7F	Chorus Send	0 - 127	00
46	00	45	1	00 - 03	Insertion Connect Type	parallel, ins A>B, ins B>A, vocoder	01
		46	1	00 - 7F	Ins-EF Reverb Send Level	0 - 127	00

Address		Size	Data Range (HEX)	Parameter Name	Settings	Default (HEX)	Notes
High	Mid	Low					
		47	1	00 - 7F	Ins-EF Chorus Send Level	0 - 127	00

TOTAL SIZE = 72 48 (HEX)

Address		Size	Data Range (HEX)	Parameter Name	Settings	Default (HEX)	Notes
High	Mid	Low					
46	30	00	1	00 - 05	ARP SF Select	SF1 - SF6	00
		01	1		reserved		
		02	2	00 - 02 05 - 2C	ARP Tempo	5..300	00 5A
		04	1		reserved		
		05	1		reserved		
		06	2		reserved		
		08	2		reserved		
		0A	2		reserved		
		0C	2		reserved		
		0E	1	00 - 01	ARP Switch	off, on	
		0F	1		reserved		
		10	1		reserved		
		11	1		reserved		
		12	1		reserved		
		13	1		reserved		
		14	1	00 - 01	ARP Loop	off, on	01
		15	1	00 - 02	ARP Hold	sync-off, off, on	01
		16	1	00 - 06	ARP Unit Multiply	50%, 66%, 75%, 100%, 133%, 150%, 200%	03
		17	1	00 - 7F	ARP Note Limit Low	C-2..G8	00
		18	1	00 - 7F	ARP Note Limit High	C-2..G8	7F
		19	1	01 - 7F	ARP Velocity Limit Low	1 - 127	01
		1A	1	01 - 7F	ARP Velocity Limit High	1 - 127	7F
		1B	1	00 - 04	ARP Key Mode	sort, thru, direct, sort+direct, thru+direct	00
		1C	1	00 - 01	ARP Velocity Mode	original, thru	00
		1D	1	00 - 01	ARP Change Timing	realtime, measure	01
		1E	1	01 - 07	ARP Quantize Value	32th, 16th_Triplet, 16th, 8th_Triplet, 8th, 4th_Triplet, 4th	03
		1F	1	00 - 64	ARP Quantize Strength	0...100%	00
		20	2	00 - 01 00 - 48	ARP Velocity Rate	0...200%	00 64
		22	2	00 - 01 00 - 48	ARP Gate Time Rate	0...200%	00 64
		24	1		reserved		
		25	1		reserved		
		26	1		reserved		
		27	1		reserved		
		28	2	00 - 01 08 - 78	ARP Swing	-120 ... 0 ... +120	01 00
		2A	1	00 - 7F	ARP Accent Velocity Threshold	off, 1 ... 127	40
		2B	1	00 - 01	ARP Accent Start Quantize	off, on	01
		2C	1	3D - 43	ARP Octave Range	-3 ... 0 ... +3	40
		2D	1	36 - 4A	ARP Output Octave Shift	-10 ... 0 ... +10	40
		2E	1	00 - 01	ARP Trigger Mode	gate, toggle	00
		2F	1	00 - 01	ARP Random SFX	off, on	01
		30	1	00 - 01	ARP Random SFX Key on Control	off, on	01
		31	1	00 - 7F	ARP Random SFX Velocity Offset	-64 ... 0 ... +63	40
		32	2	00 - 01 1C - 64	ARP Assign Velocity Rate Offset SF1	-100 ... 0 ... +100	01 00
		34	2	00 - 01 1C - 64	ARP Assign Gate Time Offset SF1	-100 ... 0 ... +100	01 00
		36	2	00 - 01 1C - 64	ARP Assign Velocity Rate Offset SF2	-100 ... 0 ... +100	01 00
		38	2	00 - 01 1C - 64	ARP Assign Gate Time Offset SF2	-100 ... 0 ... +100	01 00
		3A	2	00 - 01 1C - 64	ARP Assign Velocity Rate Offset SF3	-100 ... 0 ... +100	01 00
		3C	2	00 - 01 1C - 64	ARP Assign Gate Time Offset SF3	-100 ... 0 ... +100	01 00
		3E	2	00 - 01 1C - 64	ARP Assign Velocity Rate Offset SF4	-100 ... 0 ... +100	01 00
		40	2	00 - 01 1C - 64	ARP Assign Gate Time Offset SF4	-100 ... 0 ... +100	01 00
		42	2	00 - 01 1C - 64	ARP Assign Velocity Rate Offset SF5	-100 ... 0 ... +100	01 00
		44	2	00 - 01 1C - 64	ARP Assign Gate Time Offset SF5	-100 ... 0 ... +100	01 00
		46	2	00 - 01 1C - 64	ARP Assign Velocity Rate Offset SF6	-100 ... 0 ... +100	01 00
		48	2	00 - 01 1C - 64	ARP Assign Gate Time Offset SF6	-100 ... 0 ... +100	01 00
		4A	2	00 - 34 00 - 7B 40 - 41 00 - 7F	ARP SF1 Assign Type	off, Preset 0001 ... 6779, User 001 ... 256	04 6E MA_Pt Arp1

Address			Size	Data Range (HEX)	Parameter Name	Settings	Default (HEX)	Notes
High	Mid	Low						
		4C	2	00 - 34 00 - 7B 40 - 41 00 - 7F	ARP SF2 Assign Type	off, Preset 0001 ... 6779, User 001 ... 256	00 00	off
		4E	2	00 - 34 00 - 7B 40 - 41 00 - 7F	ARP SF3 Assign Type	off, Preset 0001 ... 6779, User 001 ... 256	00 00	off
		50	2	00 - 34 00 - 7B 40 - 41 00 - 7F	ARP SF4 Assign Type	off, Preset 0001 ... 6779, User 001 ... 256	00 00	off
		52	2	00 - 34 00 - 7B 40 - 41 00 - 7F	ARP SF5 Assign Type	off, Preset 0001 ... 6779, User 001 ... 256	00 00	off
		54	2	00 - 34 00 - 7B 40 - 41 00 - 7F	ARP SF6 Assign Type	off, Preset 0001 ... 6779, User 001 ... 256	00 00	off

TOTAL SIZE = 86 56 (HEX)

Address			Size	Data Range (HEX)	Parameter Name	Settings	Default (HEX)	Notes
High	Mid	Low						
		18	2	00 - 7F 00 - 7F	Chorus Parameter 11	:		Init value for G Chorus / Basic
		1A	2	00 - 7F 00 - 7F	Chorus Parameter 12	:		Init value for G Chorus / Basic
		1C	2	00 - 7F 00 - 7F	Chorus Parameter 13	:		Init value for G Chorus / Basic
		1E	2	00 - 7F 00 - 7F	Chorus Parameter 14	:		Init value for G Chorus / Basic
		20	2	00 - 7F 00 - 7F	Chorus Parameter 15	:		Init value for G Chorus / Basic
		22	2	00 - 7F 00 - 7F	Chorus Parameter 16	:		Init value for G Chorus / Basic
		24	1	00 - 7F	Chorus Return	-->dB...0dB...+6dB (0...96...127)	60	
		25	1	01 - 7F	Chorus Pan	L63...C...R63	40	
		26	1	00 - 7F	Send Chorus To Reverb	-->dB...0dB (0...127)	00	
		27	1		reserved			

TOTAL SIZE = 40 28 (HEX)

Address			Size	Data Range (HEX)	Parameter Name	Settings	Default (HEX)	Notes
High	Mid	Low						
46	01	00	2	00 - 7F 00 - 7F	Reverb Type	Refer to the "Effect Type List."	01 00	Rev-X Hall
		02	1	00 - 7F	Preset Number		00	Basic
		03	1		reserved			
		04	2	00 - 7F 00 - 7F	Reverb Parameter 1	Refer to the "Effect Parameter List."		Init value for Rev-X Hall / Basic
		06	2	00 - 7F 00 - 7F	Reverb Parameter 2	:		Init value for Rev-X Hall / Basic
		08	2	00 - 7F 00 - 7F	Reverb Parameter 3	:		Init value for Rev-X Hall / Basic
		0A	2	00 - 7F 00 - 7F	Reverb Parameter 4	:		Init value for Rev-X Hall / Basic
		0C	2	00 - 7F 00 - 7F	Reverb Parameter 5	:		Init value for Rev-X Hall / Basic
		0E	2	00 - 7F 00 - 7F	Reverb Parameter 6	:		Init value for Rev-X Hall / Basic
		10	2	00 - 7F 00 - 7F	Reverb Parameter 7	:		Init value for Rev-X Hall / Basic
		12	2	00 - 7F 00 - 7F	Reverb Parameter 8	:		Init value for Rev-X Hall / Basic
		14	2	00 - 7F 00 - 7F	Reverb Parameter 9	:		Init value for Rev-X Hall / Basic
		16	2	00 - 7F 00 - 7F	Reverb Parameter 10	:		Init value for Rev-X Hall / Basic
		18	2	00 - 7F 00 - 7F	Reverb Parameter 11	:		Init value for Rev-X Hall / Basic
		1A	2	00 - 7F 00 - 7F	Reverb Parameter 12	:		Init value for Rev-X Hall / Basic
		1C	2	00 - 7F 00 - 7F	Reverb Parameter 13	:		Init value for Rev-X Hall / Basic
		1E	2	00 - 7F 00 - 7F	Reverb Parameter 14	:		Init value for Rev-X Hall / Basic
		20	2	00 - 7F 00 - 7F	Reverb Parameter 15	:		Init value for Rev-X Hall / Basic
		22	2	00 - 7F 00 - 7F	Reverb Parameter 16	:		Init value for Rev-X Hall / Basic
		24	1	00 - 7F	Reverb Return	-->dB...0dB...+6dB (0...96...127)	40	
		25	1	01 - 7F	Reverb Pan	L63...C...R63	40	

TOTAL SIZE = 38 26 (HEX)

Address			Size	Data Range (HEX)	Parameter Name	Settings	Default (HEX)	Notes
High	Mid	Low						
46	03	00	2	00 - 7F 00 - 7F	Insertion A Type	Refer to the "Effect Type List."	00 00	
		02	1	00 - 7F	Preset Number		00	Basic
		03	1		reserved			
		04	2	00 - 7F 00 - 7F	Insertion A Parameter 1	Refer to the "Effect Parameter List."	00 00	
		06	2	00 - 7F 00 - 7F	Insertion A Parameter 2	:	00 00	
		08	2	00 - 7F 00 - 7F	Insertion A Parameter 3	:	00 00	
		0A	2	00 - 7F 00 - 7F	Insertion A Parameter 4	:	00 00	
		0C	2	00 - 7F 00 - 7F	Insertion A Parameter 5	:	00 00	
		0E	2	00 - 7F 00 - 7F	Insertion A Parameter 6	:	00 00	
		10	2	00 - 7F 00 - 7F	Insertion A Parameter 7	:	00 00	
		12	2	00 - 7F 00 - 7F	Insertion A Parameter 8	:	00 00	
		14	2	00 - 7F 00 - 7F	Insertion A Parameter 9	:	00 00	
		16	2	00 - 7F 00 - 7F	Insertion A Parameter 10	:	00 00	
		18	2	00 - 7F 00 - 7F	Insertion A Parameter 11	:	00 00	
		1A	2	00 - 7F 00 - 7F	Insertion A Parameter 12	:	00 00	
		1C	2	00 - 7F 00 - 7F	Insertion A Parameter 13	:	00 00	
		1E	2	00 - 7F 00 - 7F	Insertion A Parameter 14	:	00 00	
		20	2	00 - 7F 00 - 7F	Insertion A Parameter 15	:	00 00	
		22	2	00 - 7F 00 - 7F	Insertion A Parameter 16	:	00 00	

TOTAL SIZE = 36 24 (HEX)

Address			Size	Data Range (HEX)	Parameter Name	Settings	Default (HEX)	Notes
High	Mid	Low						
46	02	00	2	00 - 7F 00 - 7F	Chorus Type	Refer to the "Effect Type List."	03 00	G Chorus
		02	1	00 - 7F	Preset Number		00	Basic
		03	1		reserved			
		04	2	00 - 7F 00 - 7F	Chorus Parameter 1	Refer to the "Effect Parameter List."		Init value for G Chorus / Basic
		06	2	00 - 7F 00 - 7F	Chorus Parameter 2	:		Init value for G Chorus / Basic
		08	2	00 - 7F 00 - 7F	Chorus Parameter 3	:		Init value for G Chorus / Basic
		0A	2	00 - 7F 00 - 7F	Chorus Parameter 4	:		Init value for G Chorus / Basic
		0C	2	00 - 7F 00 - 7F	Chorus Parameter 5	:		Init value for G Chorus / Basic
		0E	2	00 - 7F 00 - 7F	Chorus Parameter 6	:		Init value for G Chorus / Basic
		10	2	00 - 7F 00 - 7F	Chorus Parameter 7	:		Init value for G Chorus / Basic
		12	2	00 - 7F 00 - 7F	Chorus Parameter 8	:		Init value for G Chorus / Basic
		14	2	00 - 7F 00 - 7F	Chorus Parameter 9	:		Init value for G Chorus / Basic
		16	2	00 - 7F 00 - 7F	Chorus Parameter 10	:		Init value for G Chorus / Basic

Address			Size	Data Range (HEX)	Parameter Name	Settings	Default (HEX)	Notes
High	Mid	Low						
46	04	00	2	00 - 7F 00 - 7F	Insertion B Type	Refer to the "Effect Type List."	00 00	
		02	1	00 - 7F	Preset Number		00	Basic
		03	1		reserved			
		04	2	00 - 7F 00 - 7F	Insertion B Parameter 1	Refer to the "Effect Parameter List."	00 00	
		06	2	00 - 7F 00 - 7F	Insertion B Parameter 2	:	00 00	
		08	2	00 - 7F 00 - 7F	Insertion B Parameter 3	:	00 00	
		0A	2	00 - 7F 00 - 7F	Insertion B Parameter 4	:	00 00	
		0C	2	00 - 7F 00 - 7F	Insertion B Parameter 5	:	00 00	
		0E	2	00 - 7F 00 - 7F	Insertion B Parameter 6	:	00 00	
		10	2	00 - 7F 00 - 7F	Insertion B Parameter 7	:	00 00	
		12	2	00 - 7F 00 - 7F	Insertion B Parameter 8	:	00 00	
		14	2	00 - 7F 00 - 7F	Insertion B Parameter 9	:	00 00	
		16	2	00 - 7F 00 - 7F	Insertion B Parameter 10	:	00 00	
		18	2	00 - 7F 00 - 7F	Insertion B Parameter 11	:	00 00	
		1A	2	00 - 7F 00 - 7F	Insertion B Parameter 12	:	00 00	

Address			Size	Data Range (HEX)	Parameter Name	Settings	Default (HEX)	Notes
High	Mid	Low						
		1C	2	00 - 7F 00 - 7F	Insertion B Parameter 13	:	00 00	
		1E	2	00 - 7F 00 - 7F	Insertion B Parameter 14	:	00 00	
		20	2	00 - 7F 00 - 7F	Insertion B Parameter 15	:	00 00	
		22	2	00 - 7F 00 - 7F	Insertion B Parameter 16	:	00 00	

TOTAL SIZE = 36 24 (HEX)

Address			Size	Data Range (HEX)	Parameter Name	Settings	Default (HEX)	Notes
High	Mid	Low						
46	05	00	2	00 - 7F 00 - 7F	Insertion L Type	Refer to the "Effect Type List."	00 00	
		02	1	00 - 7F	Preset Number		00	Basic
		03	1		reserved			
		04	2	00 - 7F 00 - 7F	Insertion L Parameter 1	Refer to the "Effect Parameter List."	00 00	
		06	2	00 - 7F 00 - 7F	Insertion L Parameter 2	:	00 00	
		08	2	00 - 7F 00 - 7F	Insertion L Parameter 3	:	00 00	
		0A	2	00 - 7F 00 - 7F	Insertion L Parameter 4	:	00 00	
		0C	2	00 - 7F 00 - 7F	Insertion L Parameter 5	:	00 00	
		0E	2	00 - 7F 00 - 7F	Insertion L Parameter 6	:	00 00	
		10	2	00 - 7F 00 - 7F	Insertion L Parameter 7	:	00 00	
		12	2	00 - 7F 00 - 7F	Insertion L Parameter 8	:	00 00	
		14	2	00 - 7F 00 - 7F	Insertion L Parameter 9	:	00 00	
		16	2	00 - 7F 00 - 7F	Insertion L Parameter 10	:	00 00	
		18	2	00 - 7F 00 - 7F	Insertion L Parameter 11	:	00 00	
		1A	2	00 - 7F 00 - 7F	Insertion L Parameter 12	:	00 00	
		1C	2	00 - 7F 00 - 7F	Insertion L Parameter 13	:	00 00	
		1E	2	00 - 7F 00 - 7F	Insertion L Parameter 14	:	00 00	
		20	2	00 - 7F 00 - 7F	Insertion L Parameter 15	:	00 00	
		22	2	00 - 7F 00 - 7F	Insertion L Parameter 16	:	00 00	
		24	2	00 - 7F 00 - 7F	Insertion L Parameter 17	:	00 00	
		26	2	00 - 7F 00 - 7F	Insertion L Parameter 18	:	00 00	
		28	2	00 - 7F 00 - 7F	Insertion L Parameter 19	:	00 00	
		2A	2	00 - 7F 00 - 7F	Insertion L Parameter 20	:	00 00	
		2C	2	00 - 7F 00 - 7F	Insertion L Parameter 21	:	00 00	
		2E	2	00 - 7F 00 - 7F	Insertion L Parameter 22	:	00 00	
		30	2	00 - 7F 00 - 7F	Insertion L Parameter 23	:	00 00	
		32	2	00 - 7F 00 - 7F	Insertion L Parameter 24	:	00 00	
		34	2	00 - 7F 00 - 7F	Insertion L Parameter 25	:	00 00	
		36	2	00 - 7F 00 - 7F	Insertion L Parameter 26	:	00 00	
		38	2	00 - 7F 00 - 7F	Insertion L Parameter 27	:	00 00	
		3A	2	00 - 7F 00 - 7F	Insertion L Parameter 28	:	00 00	
		3C	2	00 - 7F 00 - 7F	Insertion L Parameter 29	:	00 00	
		3E	2	00 - 7F 00 - 7F	Insertion L Parameter 30	:	00 00	
		40	2	00 - 7F 00 - 7F	Insertion L Parameter 31	:	00 00	
		42	2	00 - 7F 00 - 7F	Insertion L Parameter 32	:	00 00	

TOTAL SIZE = 68 44 (HEX)

Address			Size	Data Range (HEX)	Parameter Name	Settings	Default (HEX)	Notes
High	Mid	Low						
46	08	00	1	00 - 7F	Controller Set 1 Depth	-64 - +63	40	
		01	1	00 - 0E	Controller Set 1 Source	0: PB, 1: MW, 3: AT, 4: FC, 5: FS, 6: RB, 7: BC, 8: AKN1, 9: AKN2, 12: FC2, 13: ASW1, 14: ASW2	01	
		02	2	00 - 00 00 - 65	Controller Set 1 Destination	0 - 101	00 00	
		04	1	00 - 7F	Controller Set 2 Depth	-64 - +63	40	
		05	1	00 - 0E	Controller Set 2 Source	0: PB, 1: MW, 3: AT, 4: FC, 5: FS, 6: RB, 7: BC, 8: AKN1, 9: AKN2, 12: FC2, 13: ASW1, 14: ASW2	01	
		06	2	00 - 00 00 - 65	Controller Set 2 Destination	0 - 101	00 00	
		08	1	00 - 7F	Controller Set 3 Depth	-64 - +63	40	
		09	1	00 - 0E	Controller Set 3 Source	0: PB, 1: MW, 3: AT, 4: FC, 5: FS, 6: RB, 7: BC, 8: AKN1, 9: AKN2, 12: FC2, 13: ASW1, 14: ASW2	01	
		0A	2	00 - 00 00 - 65	Controller Set 3 Destination	0 - 101	00 00	
		0C	1	00 - 7F	Controller Set 4 Depth	-64 - +63	40	
		0D	1	00 - 0E	Controller Set 4 Source	0: PB, 1: MW, 3: AT, 4: FC, 5: FS, 6: RB, 7: BC, 8: AKN1, 9: AKN2, 12: FC2, 13: ASW1, 14: ASW2	08	
		0E	2	00 - 00 00 - 65	Controller Set 4 Destination	0 - 101	00 00	
		10	1	00 - 7F	Controller Set 5 Depth	-64 - +63	40	
		11	1	00 - 0E	Controller Set 5 Source	0: PB, 1: MW, 3: AT, 4: FC, 5: FS, 6: RB, 7: BC, 8: AKN1, 9: AKN2, 12: FC2, 13: ASW1, 14: ASW2	09	
		12	2	00 - 00 00 - 65	Controller Set 5 Destination	0 - 101	00 00	
		14	1	00 - 7F	Controller Set 6 Depth	-64 - +63	40	
		15	1	00 - 0E	Controller Set 6 Source	0: PB, 1: MW, 3: AT, 4: FC, 5: FS, 6: RB, 7: BC, 8: AKN1, 9: AKN2, 12: FC2, 13: ASW1, 14: ASW2	03	
		16	2	00 - 00 00 - 65	Controller Set 6 Destination	0 - 101	00 00	

TOTAL SIZE = 24 18 (HEX)

MIDI PARAMETER CHANGE TABLE (DRUM VOICE KEY)

Address			Size	Data Range (HEX)	Parameter Name	Settings	Default (HEX)	Notes
High	Mid	Low						
47	ee	00	1	00 - 01	Element Switch	off, on	01	
		01	1		reserved			
		02	2	00 - 14 01 - 6E	Wave Number	1 - 2670	0D 62	
		04	1	00 - 01	Receive Note Off	off, on	00	
		05	1	00 - 01	Key Assign Mode	single, multi	01	
		06	1	00 - 7F	Alternate Group	0: off, 1 - 127	00	
		07	1	01 - 7F	Pan	L63 - C - R63	40	
		08	1	00 - 7F	Random Pan Depth	0 - 127	00	
		09	1	00 - 7F	Alternate Pan Depth	L64 - 0 - R63	40	
		0A	1	00 - 7F	Reverb Send Level	0 - 127	5A	
		0B	1	00 - 7F	Chorus Send Level	0 - 127	00	
		0C	1	00 - 02	Insertion Effect	thru, insA, insB	00	
		0D	1		reserved			
47	ee	0E	1	00 - 7F	Element Level	0 - 127	7F	
		0F	1	00 - 7F	Level Velocity Sensitivity	-64 - +63	40	
		10	1		reserved			
		11	1	00 - 7F	AEG Attack Time	0 - 127	00	
		12	1	00 - 7F	AEG Decay 1 Time	0 - 127	60	
		13	1	00 - 7F	AEG Decay 2 Time	0 - 126, hold	50	
		14	1		reserved			
		15	1		reserved			
		16	1		reserved			
		17	1	00 - 7F	AEG Decay 1 Level	0 - 127	7F	
		18	1		reserved			
		19	1		reserved			
47	ee	1A	1	10 - 70	Coarse Tune	-48 - +48	40	
		1B	1	00 - 7F	Fine Tune	-64 - +63	40	
		1C	1	00 - 7F	Pitch Velocity Sensitivity	-64 - +63	40	
		1D	1		reserved			
47	ee	1E	2	00 - 01 00 - 7F	LPF Cutoff Frequency	0 - 255	01 7F	
		20	1	00 - 7F	LPF Cutoff Velocity Sensitivity	-64 - +63	40	
		21	1	00 - 7F	LPF Resonance	0 - 127	00	
		22	2	00 - 01 00 - 7F	HPF Cutoff Frequency	0 - 255	00 00	
		24	1	00 - 05	EQ Type	2 Band, P.EQ, Boost6, Boost12, Boost18, thru	00	
		25	1	00 - 1F	EQ Q	0 - 31 (0.7 - 10.3)	00	
		26	2	00 - 01 2E - 7B	EQ 1 Frequency	2 Band: 46 - 182, P.EQ: 83 - 251	00 36	
		28	1	20 - 60	EQ 1 GAIN	-32 - +32	40	
		29	1		reserved			
		2A	2	01 - 01 03 - 71	EQ 2 Frequency	2 Band: 131 - 241	01 67	
		2C	1	20 - 60	EQ 2 GAIN	-32 - +32	40	
		2D	1		reserved			

TOTAL SIZE = 46 2E (HEX)

ee = element number (00 - 48; C0 - C6)

Function...	Transmitted	Recognized	Remarks
Basic Channel Default Changed	1 - 16 1 - 16	1 - 16 1 - 16	Memorized
Mode Default Messages Altered	3 X *****	1 1 - 4 (m=1) *2 X	Memorized
Note Number : True voice	0 - 127 *****	0 - 127 0 - 127	
Velocity Note ON Note OFF	O 9nH,v=1-127 X 9nH,v=0	O v=1-127 X	
After Touch Key's Ch's	X O *3	X O *1	
Pitch Bend	O	O *1	
Control Change	0,32 O 1,7,10,11 O 5 X 6,38 X 64 O 65 X 66 X 71-75 O 91,93 O 96-97 X 100-101 X 1-95 O	O *1 O *1 O *1 O *1 O *1 O *1 O *1 O *1 O *1 O *1 O *1 O *1	Bank Select Portamento Time Data Entry Sustain Sw Portamento Sw Sostenuto Sound Controller Effect Depth RPN Inc,Dec RPN LSB,MSB Assignable Cntrl
Prog Change : True #	O 0 - 127 *1 *****	O 0 - 127 0 - 127	
System Exclusive	O	O	
Common : Song Pos. : Song Sel. : Tune	X X X	X X X	
System : Clock Real Time : Commands	X X	O X	
Aux : All Sound Off : Reset All Cntrls : Local ON/OFF Mes- : All Notes OFF sages: Active Sense : Reset	X X X X O X	O (120,126,127) O (121) X O (123-125) O X	
Notes: *1 Recognized if receive switch is on. *2 "m" is always treated as "1" regardless of its actual value. *3 Even though the keyboard itself doesn't support after touch control, after touch data can be transmitted via the Arpeggio function when a User Arpeggio with after touch data is selected.			

Mode 1 : OMNI ON , POLY
 Mode 3 : OMNI OFF, POLY

Mode 2 : OMNI ON ,MONO
 Mode 4 : OMNI OFF,MONO

O : Yes
 X : No

Function...	Transmitted	Recognized	Remarks
Basic Channel Default Changed	1 - 16 X	1 - 16 X	Memorized
Mode Default Messages Altered	X X *****	X X X	
Note Number : True voice	0 - 127 *****	0 - 127	
Velocity Note ON Note OFF	O 9nH,v=1-127 X 9nH,v=0	O 9nH,v=1-127 X 9nH,v=0	
After Touch Key's Ch's	O O	O O	
Pitch Bend	O	O	
Control Change 0-121	O	O	
Prog Change : True #	O 0 - 127 *****	O 0 - 127	
System Exclusive	O	O	
Common : Song Pos. : Song Sel. : Tune	O *1 O *1 X	O *1 O *1 X	
System : Clock Real Time : Commands	O *2 O *1	O *3 O *1	
Aux : All Sound Off : Reset All Cntrls : Local ON/OFF Mes- : All Notes OFF sages: Active Sense : Reset	O O O X X X	O O O X X X	
Notes:	*1 if Seq Control in/out is enabled. *2 if MIDI Clock Out is on. *3 if MIDI Sync is MIDI. send MMC(stop,deffered play,locate) if sync mode is MTC. receive MTC quarter frame message if sync mode is MTC.		

Mode 1 : OMNI ON , POLY
 Mode 3 : OMNI OFF, POLY

Mode 2 : OMNI ON ,MONO
 Mode 4 : OMNI OFF,MONO

O : Yes
 X : No



Yamaha Web Site (English)
<http://www.yamahasyth.com/>
Yamaha Manual Library
<http://www.yamaha.co.jp/manual/>