

# GUIDE TO YOUR YAMAHA ELECTONE BK-7



# CONTENTS

	Page
Introduction.....	1
This is Your Yamaha Electone BK-7 .....	2
Keyboards .....	3
Tone Levers .....	4
Effect Levers.....	7
Effect Controls .....	9
Sound-in-Motion Tremolo .....	10
Auto Rhythm Section .....	11
Starting Rhythm with the Foot Switch .....	13
Auto Bass/Chord Section .....	14
To Play in Rhythm.....	19
To Fully Enjoy Your Electone .....	21
Care of Your Electone .....	22
Do Not Be Alarmed If .....	23
Specifications .....	25

# Introduction

Congratulations upon your selection of this Yamaha Electone. It is one of the world's most advanced musical instruments, carefully designed and built to provide a lifetime of musical enjoyment.

To make sure you derive the most from its generous features and durable IC & FET circuitry, please read this manual thoroughly before attempting to play. Then keep it handy for reference. Use it to develop your own techniques and to teach others. With a little care your Electone will become a creative center of family enjoyment for decades.



# This is Your Yamaha Electone BK-7

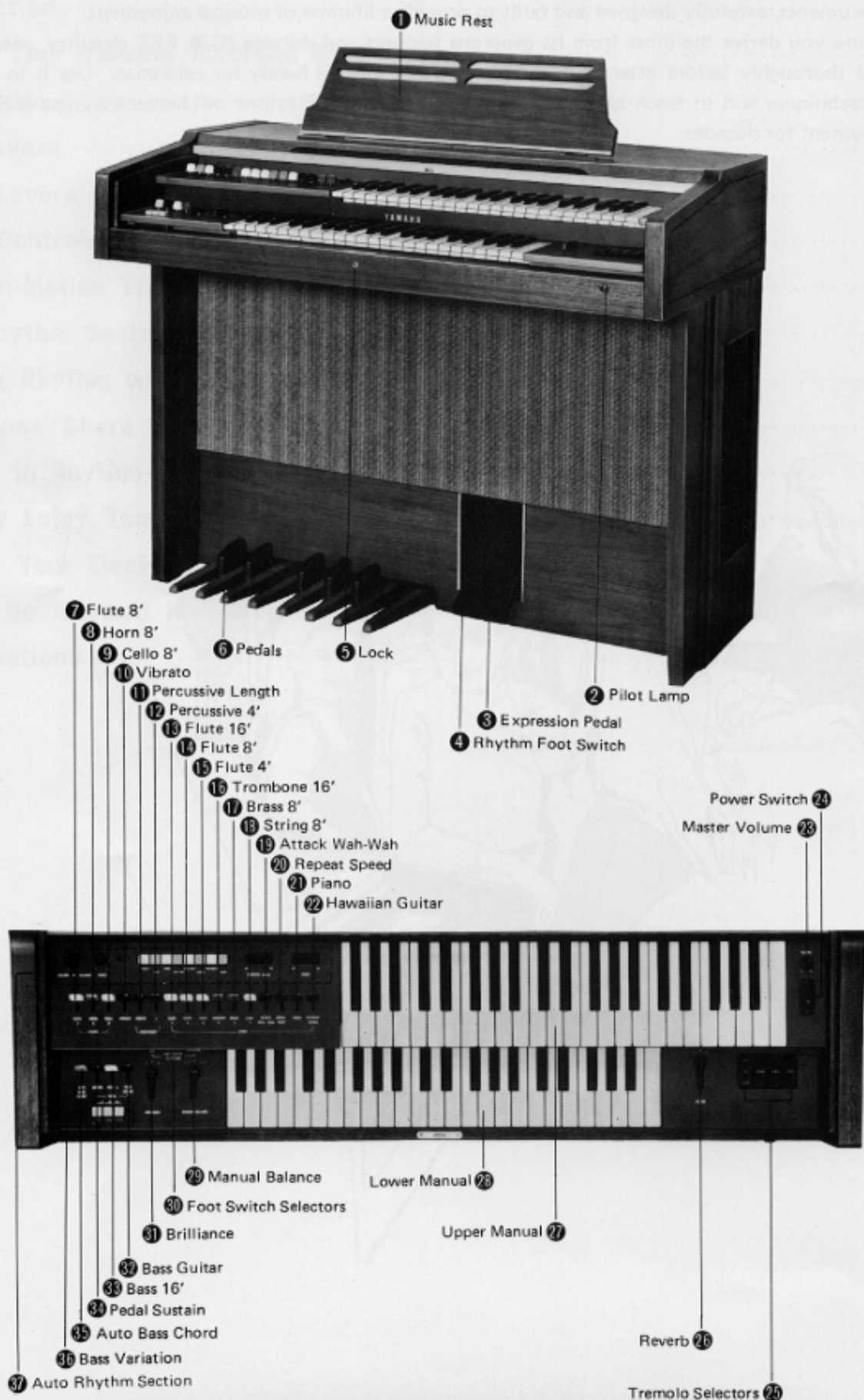

# Keyboards

The BK-7 has three keyboards. The upper two are called "manuals" and the other, for the feet, composed of "pedals."

Upper Manual	44 keys	(3 $\frac{2}{3}$ octaves)
Lower Manual	44 keys	(3 $\frac{2}{3}$ octaves)
Pedals	13 pedals	(1 octave)

The Electone is designed to permit playing the melody on the upper manual with the right hand, the chords on the lower manual with the other, and bass notes on the pedals with either foot.

All keys and pedals are arranged in the traditional keyboard method: two black keys, three black keys. Each white key has a name (from A to G), and the blacks are sharps or flats. "C" is always the white key just below the left black key in the two-black-key group. Any complete set of seven white keys and five black keys is called an "octave."

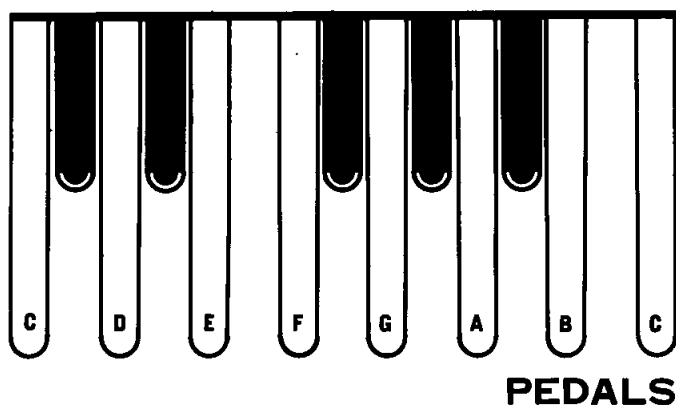
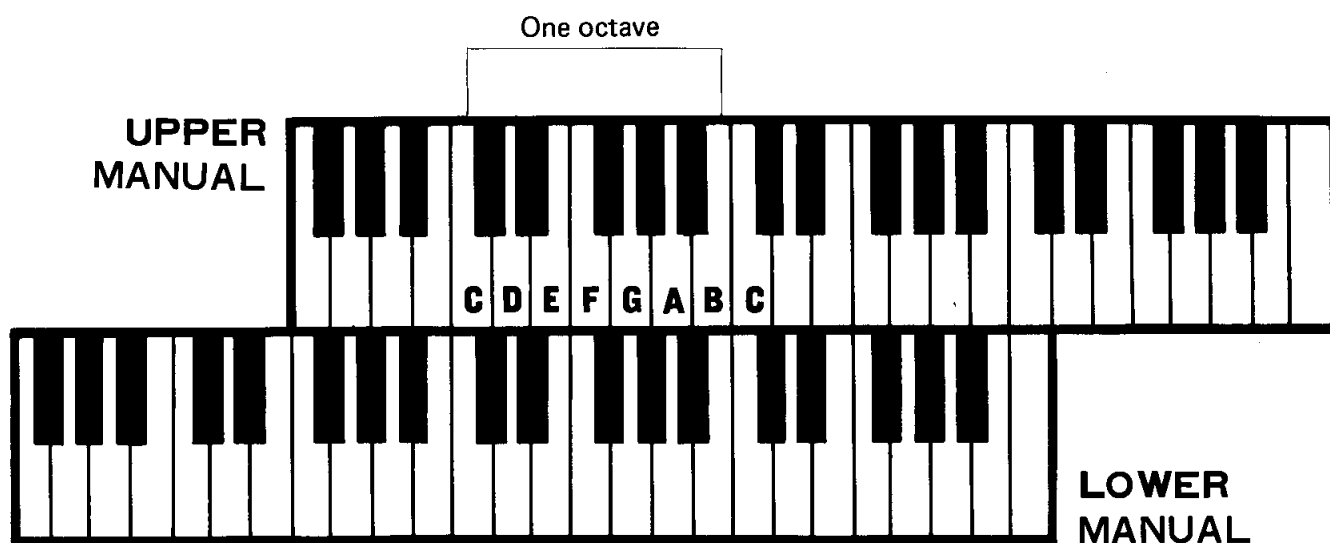

# Tone Levers

To the left of both upper and lower manuals are series of tone levers which control the voices (instrument sounds) which will sound when the keys are depressed. They are divided into groups for upper, lower and pedals, so that different registrations can be set for each.

Upper Manual Levers	8 voices
Lower Manual Levers	3 voices
Pedals	2 voices

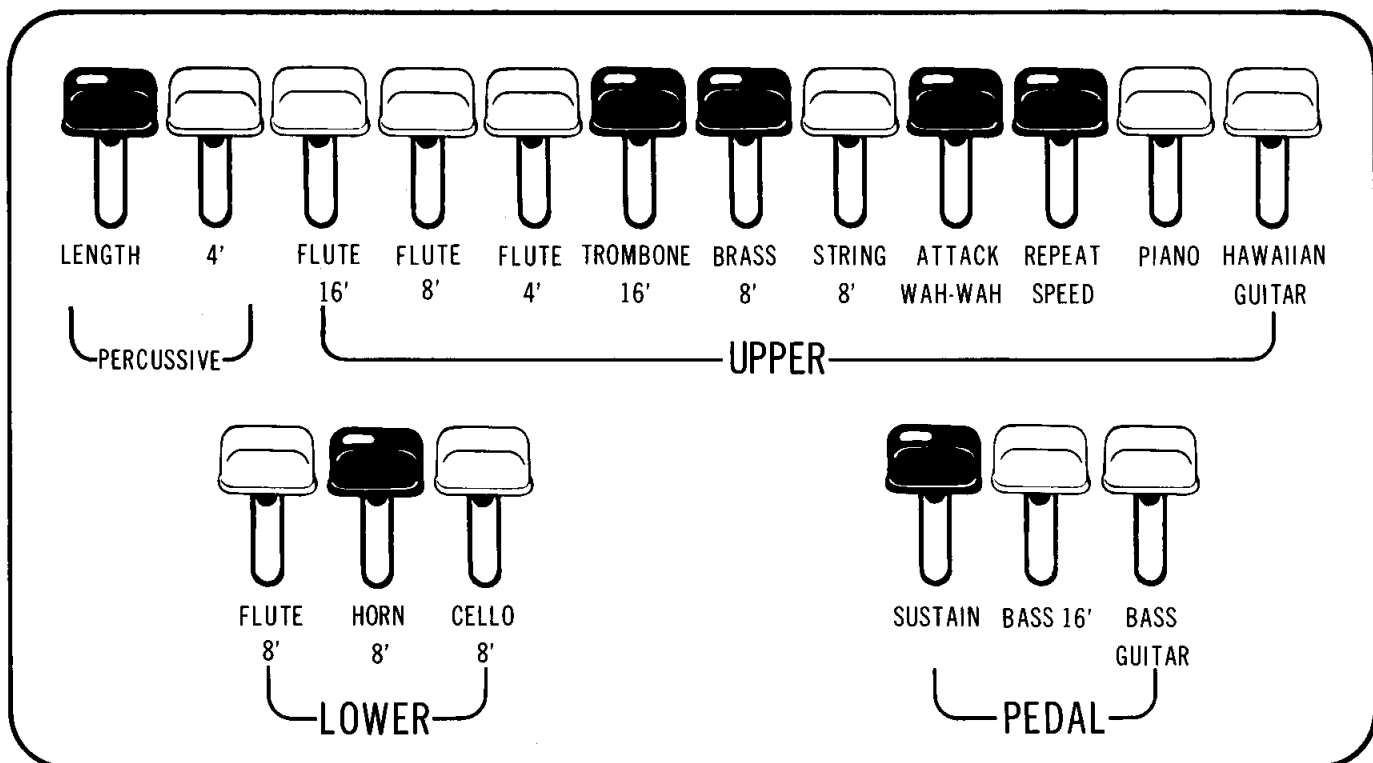

## Exclusive Yamaha Tone Lever System

Each lever provides two methods of control. One is by continuously moving the lever from off to full, to achieve the exact setting for that tone, and thus balancing the overall tone setting with perfect precision. Each lever also has two easy-to-feel click stops, at 1/3 and 2/3 positions. This lets you refine any setting with mathematical precision and no guesswork in a matter of seconds.

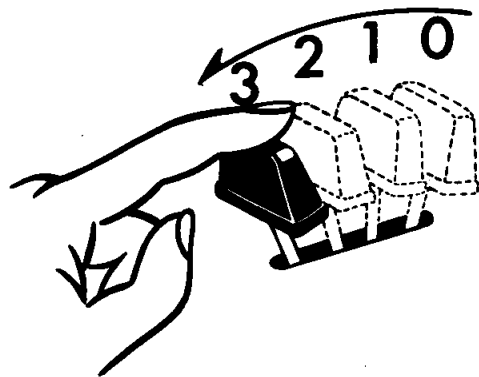

## Upper Preset Voices

Your BK-7 has two upper preset tone levers (Piano and Hawaiian Guitar). These on/off levers are special tonal blends that most closely resemble the instruments. These levers have two characteristics which must be remembered. Since they are factory preset, they automatically cancel all other upper manual tone lever settings. In addition, precedence is to the right. This means that if both levers are switched on, the Hawaiian Guitar will take effect.

## Pitches or Footages

The BK-7 has three different pitch levels, indicated by the numbers 16', 8' and 4'. These are standard organ abbreviations showing the tone's pitch in relation to the fundamental (written note). An 8' tone will sound just as it has been written. A 16' tone (meaning that the wave length of the vibrations are twice as long as 8', or half as fast) will provide a tone exactly one octave lower than the written note. Similarly, 4' tones are one octave higher than the written note.

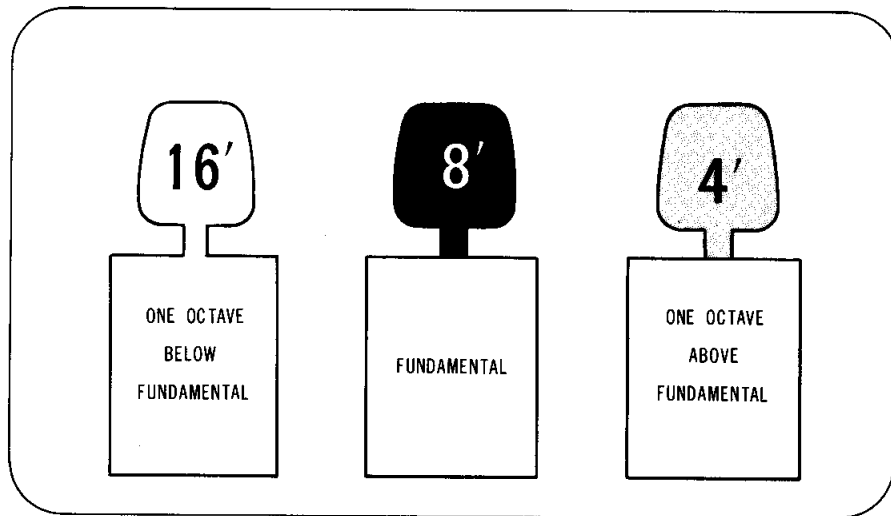

For example, if you press middle C, sound will be produced corresponding to the keys in the chart below.

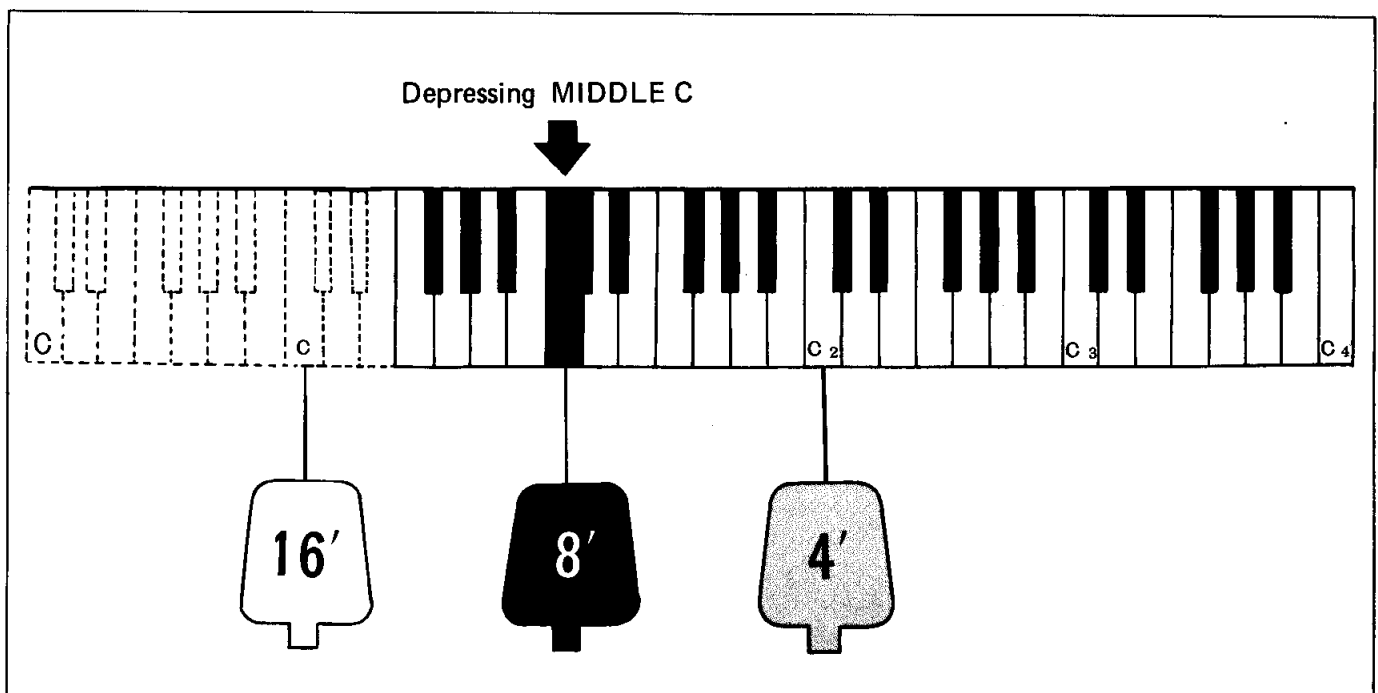

## Tone Lever Registration

For best performance, you should always take into consideration the relative tone volume balance among the three keyboards i.e., upper manual, lower manual and pedals.

When you wish to emphasize the melody played on the upper manual, for example, the volume of the lower manual and pedals should be kept under that of the upper manual. On the contrary, if you want to stress the accompaniment part on the lower manual or pedals, the volume of that particular keyboard should be adjusted relatively louder than the others.

Yamaha's unique variable tone levers you control this relative tone volume among three keyboards. Judge by your own ears and adjust the position of the levers in advance.

### (EXAMPLE)

#### ● UPPER

FLUTE 16'	FLUTE 8'	FLUTE 4'	TROMBONE 16'	BRASS 8'	STRING 8'	ATTACK WAH-WAH	REPEAT SPEED	PIANO	HAWAIIAN GUITAR
<b>3</b>	<b>0</b>	<b>2</b>	<b>0</b>	<b>3</b>	<b>0</b>	<b>0</b>	<b>0</b>	<b>0</b>	<b>0</b>

#### ● LOWER

FLUTE 8'	HORN 8'	CELLO 8'
<b>2</b>	<b>0</b>	<b>2</b>

#### ● PEDALS

SUSTAIN	BASS 16'	BASS GUITAR
<b>0</b>	<b>2</b>	<b>2</b>



# Effect Levers

These levers control a variety of effects which add a host of tonal variations to the Electone's voices. Each lever works in the same way as the tone levers, with both infinitely-variable continuous control and click-stop settings.

## Upper Percussive ⑪ ⑫

Changing the beginning of some or all notes can do wonders for lively selections. Your Electone's percussive effects provide subtle but important shading at the moment each note is heard. The special popping 4' percussive drive can be smoothly blended into all upper manual tones with a single variable lever percussive 4', and a separate lever percussive length regulates the length of decay for this effect.

With percussive, use a detached fingering. Each note should be played cleanly; slurred notes will diminish the percussive impact.

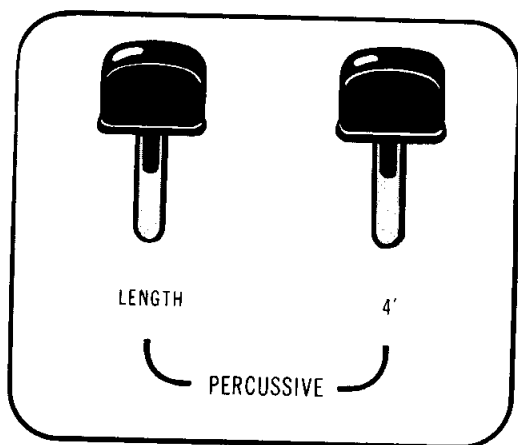

## Vibrato ⑩

Vibrato is a wavering of the tone. You will see violin and cello players use it freely by an oscillating motion of the left hand. It increases the emotional quality of the violin tone. This vibrato lever produces the same vibrato effect.

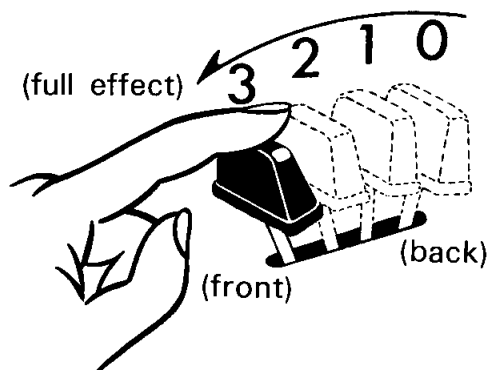

## Tone Lever Registration

### ● Repeat Speed 20

Cuts and repeats each note just like the double-strumming effect of a mandolin. The lever provides continuous speed adjustment to create a full variety of different moods.

Affects upper manual notes only.



### ● Pedal Sustain 21

This control provides continuous adjustment of the sustain effect on the pedals. For the pedals, this is the only sustain control, and it affects all pedal tones with the exception of Bass Guitar, which sustains automatically.

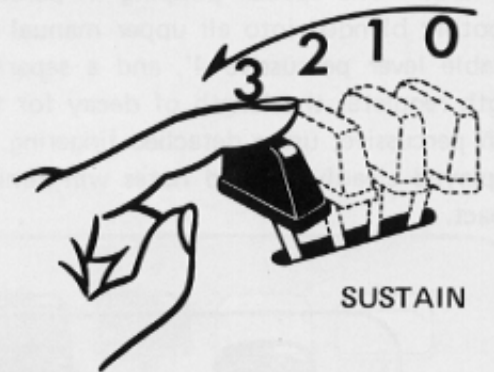

### ● Attack Wah-Wah 19

Provides a subtle muting effect at the beginning of each upper manual note. It works on successive notes even if the first is held down.



### ● Glide (Located to the left of the lower manual and Expression Pedal) 4 20

Turning the Glide tablet "ON" and depressing any key, all notes will sound slightly lower (approx. 100 cents) than the true pitch when the foot switch on the expression pedal is pushed to the left with your toe. When the foot switch is released, the pitch will gradually return to normal. This effect is excellent when playing Hawaiian music.

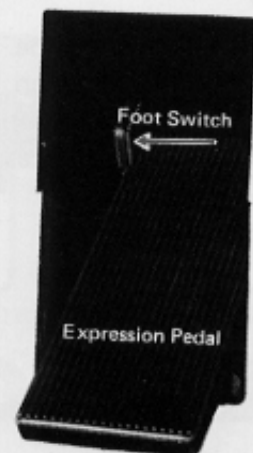

# Effect Controls

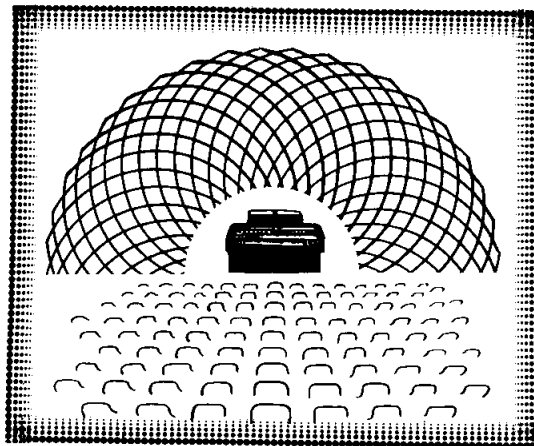
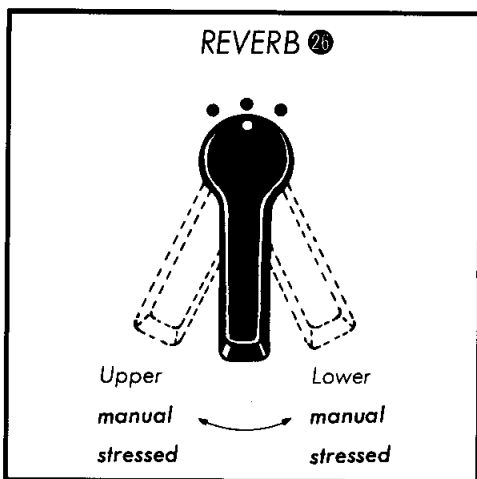

## Reverb 26

Reverberation is the quality that makes your playing sound full and rich, as if you were on the stage of a large hall or auditorium. This control is continuous, so that the reverberatory effect can be set to any degree of strength, as the music requires.

## Manual Balance 29

This control governs the relative strength of the upper and lower manuals. It is normally left in the center position, but can be shifted to stress the melody or accompaniment in a selection or passage.

This control can also be used to compensate for a higher number of total tone lever settings (which would ordinarily result in higher volume) on one of the two manuals.

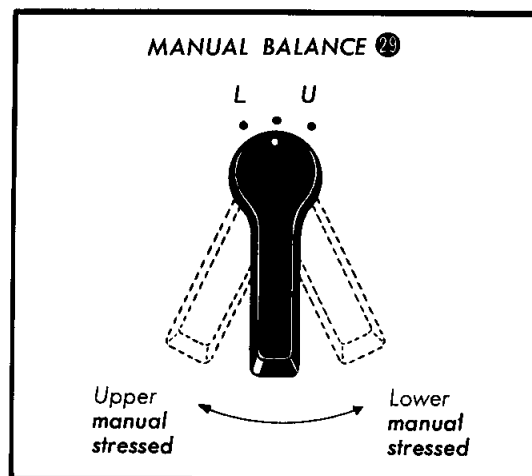

## Brilliance 31

With this single, continuously-variable control you can pinpoint the degree of overall softness or clarity desired for any mood of music.

Note: Brilliance does not function with Flute sounds. In order to reduce multiple harmonics in the high range, special resistors and condensers are used. They unfortunately limit the Brilliance effect for flute sound, as well as pedal tones. Brilliance really shines for strings, oboe and brass, where the harmonics are desired and therefore left untouched.

# Sound·in·Motion Tremolo

A rich, vibrant rush of sound that can only leave you wondering whether its source is really a single instrument! This is the tremolo which imparts a vibrancy subtly different from that of the vibrato to all notes played on the Yamaha BK-7.

This tremolo is produced by a unique design which features a smaller version of Yamaha's unique *Natural Sound Speaker*, already well known for its revolutionary tonal realism.

The uniqueness of this construction is such that instead of the rotating acoustic reflector of conventional systems, a small Natural Sound Speaker itself rotates. Rotation at either one (Chorus) or seven (Tremolo) times per second is possible so that the use of this effect lends itself equally well to light popular music and to the grandeur and magnificence of religious compositions. The smooth, rich tones which originate from the Yamaha Electone BK-7 create a circle of sound which fills any room to overflowing.

In addition, the Electone BK-7 also has an Ensemble effect, and a control arrangement whereby any of the three effects—chorus, tremolo or ensemble—can be applied selectively to only one of the manuals. The Tremolo selectors which accomplish this are the black tablets to the right of the lower manual. Each has a simple ON-OFF type action which allows quick operation while playing.

**Voice** This tablet channel the sound into the main speaker or the rotary speaker, as desired.

**Ensemble** The use of this tablet with the voice tablet above allows sound to flow from both rotary and main speakers simultaneously.

**Tremolo** Turning this tablet on turns the rotary speaker at seven revolutions per second.

**Chorus** This tablet turns the rotary speaker at one revolution per second.

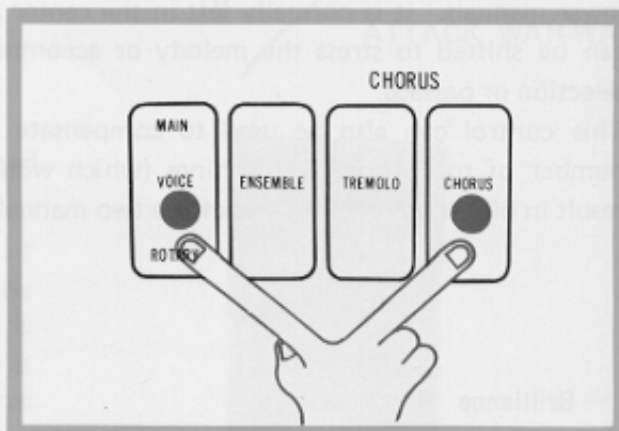
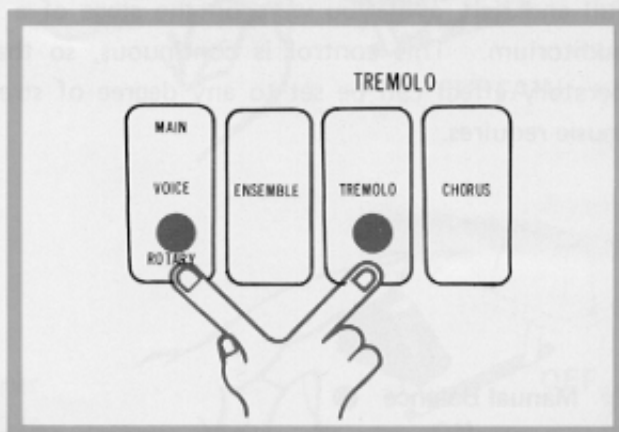
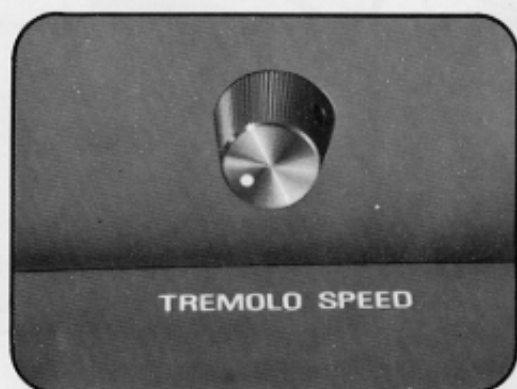

**Note:** There is a bit of noise when the rotary speaker is switched on.

This too is a mechanical noise stemming from the spinning speaker. Special mountings help keep this sound at an absolute minimum.

# Auto Rhythm Section

This section provides eight catchy rhythms, each one called forth by a simple button. In addition to a combined volume and balance knob, tempo control and tempo indicator light, there are two other switches: ordinary Start and the Yamaha Synchro-Start which begins the rhythm accompaniment on the first beat of a measure when the first lower manual or pedal note is struck. A foot switch fitted on the expression pedal lets you cut and restart the rhythm at any point during play.

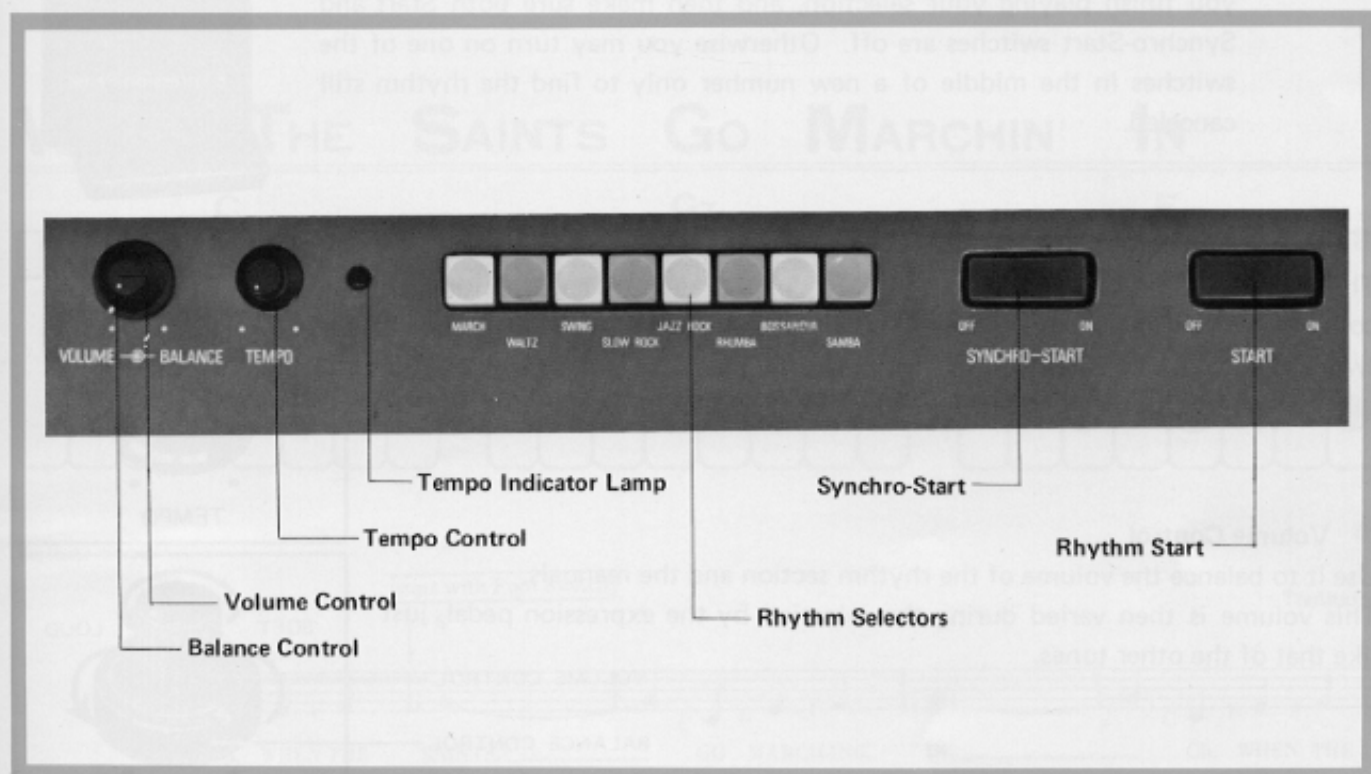

## ● Rhythm Start

For instant rhythm at the beginning of a selection. Push the rhythm selector desired, get the beat set in your mind by watching the indicator lamp, (when the Synchro-Start switch is on) and then turn the Start switch on.

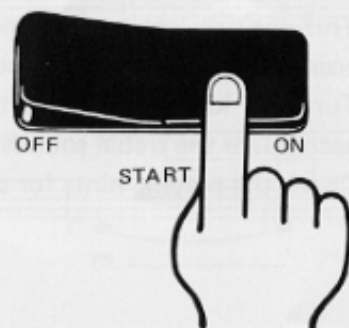

## ● Synchro-Start

Select the rhythm, switch on the Synchro-Start and begin to play once you have the beat established. The rhythm will begin as soon as you strike a lower manual or pedal note. This switch permits you to lead in with a rhythm-free melody at first if so desired.

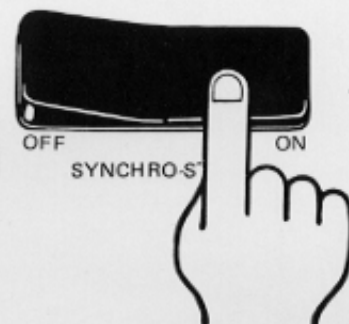

### ● Rhythm Stop (Foot Switch) ④

This switch is located in the expression pedal housing to the left of the pedal. Once the rhythm is on, push this switch once to instantly stop it, once again to restart. It lets you stop and restart the rhythm in the middle of a selection without using your hand.

**Note :** After the foot switch has been used, be sure it is reset to normal after you finish playing your selection, and then make sure both Start and Synchro-Start switches are off. Otherwise you may turn on one of the switches in the middle of a new number only to find the rhythm still canceled.

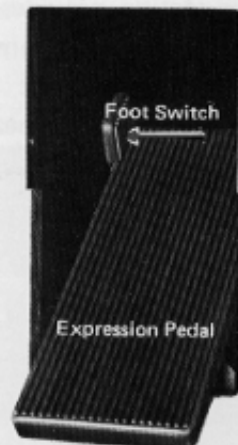

### ● Tempo Control

The tempo of the Auto Rhythm section can be adjusted by a continuous control knob. This is best accomplished by turning on the Synchro-Start switch. Although no sound will be produced, the indicator lamp will flash each quarter note, letting you visually check the tempo while you adjust.

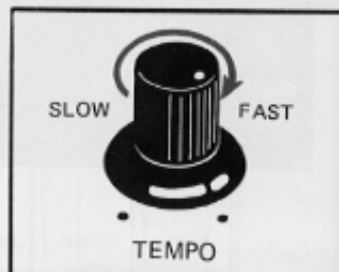

### ● Volume Control

Use it to balance the volume of the rhythm section and the manuals.

This volume is then varied during the selection by the expression pedal, just like that of the other tones.

VOLUME CONTROL

BALANCE CONTROL

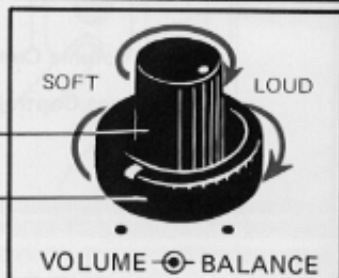

### ● Balance Control

This control lets you balance the low rhythm sounds, such as drums, and the high sounds (i.e. cymbals) according to your mood and the selection. It can make a big difference even when using the same rhythm. Turn the knob to the right to accentuate the higher (treble) sounds, to the left for lower (bass). If you accentuate the treble sounds the rhythm becomes brighter and more cheerful.

Check the playing hints for specific settings.



# Starting Rhythm with the Foot Switch

Although the foot switch is mainly for stopping and then restarting the rhythm, you can turn on the rhythm with either start switch, then shut it off with the foot switch before beginning to play. This way, when you are ready for the rhythm you can switch it on with your foot.

Lets you stop and then restart the rhythm in the middle of a selection without using your hands.

For this reason, be sure that both Start and Synchro-Start switches are turned off after each selection.

## WHEN THE SAINTS GO MARCHIN' IN

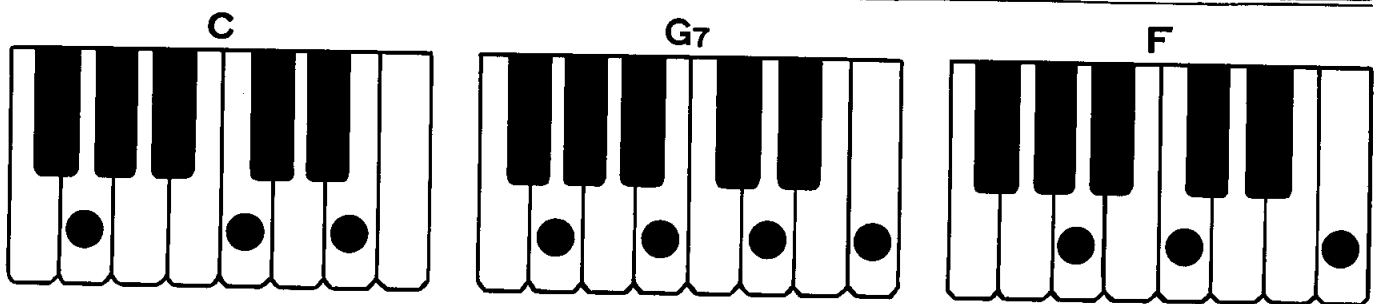

Rhythm: Swing

Moderately

start with Foot Switch

Traditional

Oh, WHEN THE SAINTS, GO MARCH-ING IN, Oh, WHEN THE  
 SAINTS GO MARCH-ING IN, Oh, Lord, I want to be in that,  
 num-ber, WHEN THE SAINTS GO MARCH-ING IN.

# Auto Bass/Chord Section

Your new BK-7 is equipped with a lever marked Auto Bass/Chord. When used in conjunction with the Automatic Rhythm (see page 11), it enables you to play just about any combination of alternating bass-chord rhythms simply by sustaining (holding down constantly) a chord on the lower manual. From your very first, simple melody, you will be sounding like a pro. Here is all you have to do.

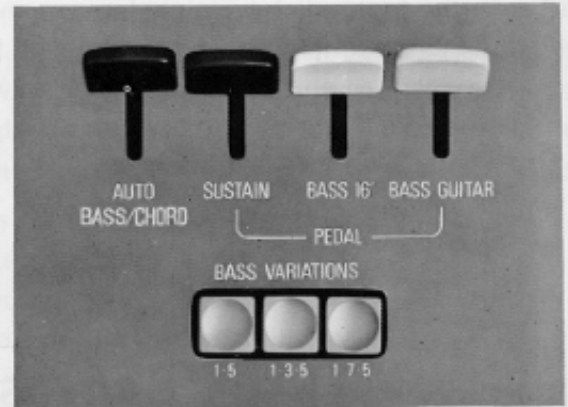

## ● Move the Auto Bass/Chord

Move the Auto Bass/Chord lever toward you. You have now engaged the memory system and deactivated the pedals (as long as this lever is in the engaged position, you cannot play your Electone as a conventional organ).

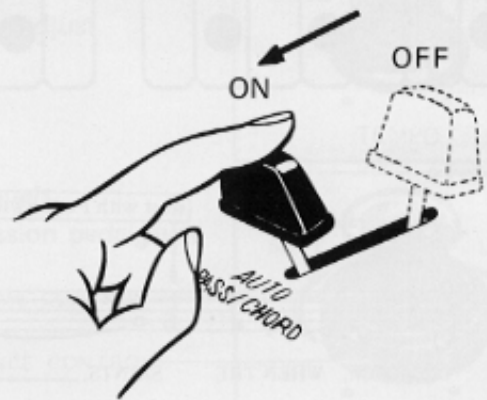

Push the Bass variation button marked 1.5 right below the Auto Bass/Chord lever.

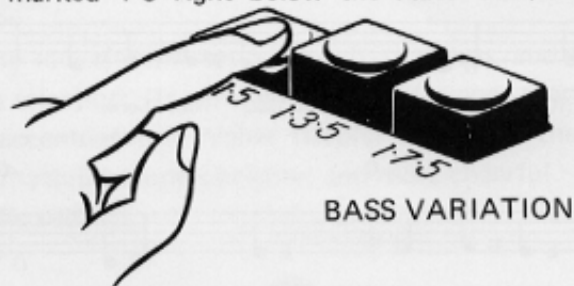

Select one of the automatic rhythm patterns and push the corresponding button down until it clicks and stays down.

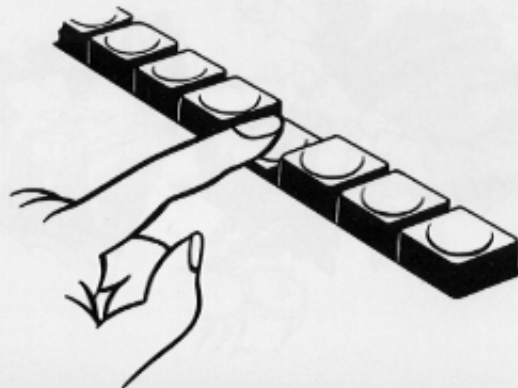



Immediately to the right of the rhythm buttons you will find two rocker type switches. Push the ON side (right) of the one marked Synchro-Start. (The one marked simply Start is to be used when you wish to continue hearing the automatic rhythm even after releasing your chord on the lower manual.) Now be sure you have at least one stop for each: Upper Manual, Lower Manual, and Pedals. You are now ready to play.

Form one of the following type of chords on the lower manual with your left hand in any inversion:

Major	Seventh
Minor	Minor Seventh

These are the only chord types for which the memory unit can supply the proper bass note. Play all the notes in the chord at the same time. The unit should now be working. Adjustments may be necessary to the Tempo and Volume knob to the left of the Automatic Rhythm unit (see page 12).

Adjustments may also be required to balance the relative volume of bass, chords, and solo (upper) manual; do this in the same way you would if playing conventionally. When the first chord is played, the unit will begin to operate on the downbeat, or first beat of the measure. When the chord is released you will not hear any more sound. When a new chord is played, the unit will again begin on the downbeat.

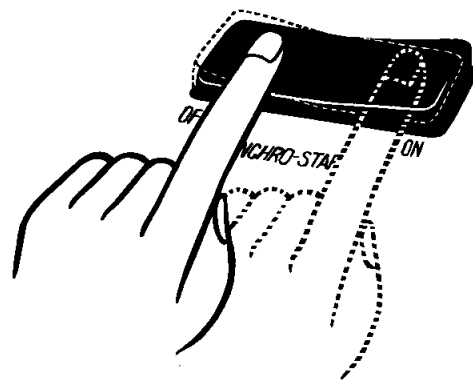
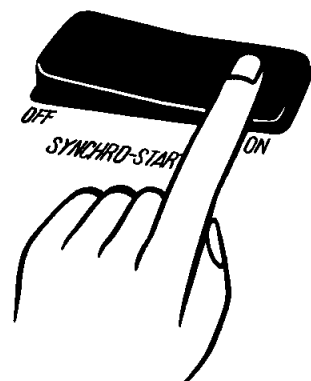

### Bass Variation Buttons

Just below the Auto Bass/Chord lever are three Bass Variation buttons, marked 1 · 5 (left) 1 · 3 · 5 (center), and 1 · 7 · 5 (right). The numbers under the buttons correspond to the notes on the musical scale in any given key and indicate what bass notes are available in the memory unit when a particular button is depressed. The type of chord and the automatic rhythm used will determine the actual note (and their sequence) that you hear.

The chart on the next page which indicates by scale step what bass notes will sound with each possible combination (Note: for the unit to perform correctly, one and only one button should be down in the Bass Variation and Automatic Rhythm sections).

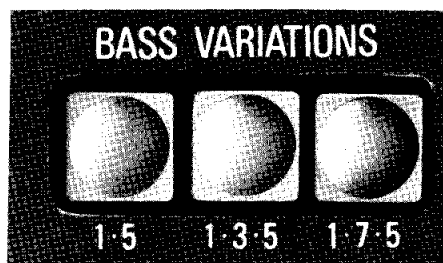
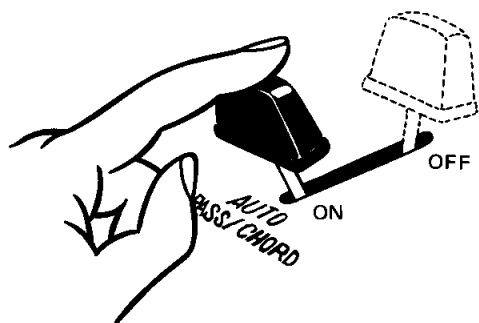

**Bass Variation**

1-5

**Type of Chord**

Major
Minor
Seventh
Minor Seventh

**Rhythms Effected**

March, Waltz, Swing, Slow Rock,
Rhumba, Bossanova, Samba

**Bass Notes Played**

1-5

**Explanation:** This is the basic pattern; it alternates the root (1) and fifth (5) in the bass regardless of rhythm chosen or type of chord. The one exception is the Jazz Rock rhythm, which never plays anything but the root in the bass.

**Bass Variation**

1-3-5

**Type of Chord**

Major
Minor
Seventh
Minor Seventh

**Rhythms Effected**

March, Waltz, Swing, Bossanova
Slow Rock, Rhumba, Samba

**Bass Notes Played**

1-5

1-3-5

**Explanation:** This selector effects only the Slow Rock, Rhumba and Samba rhythms, with which it will play a root (1), third (3), and fifth (5) pattern. All other rhythms function as with the (1-5) selector.

**Bass Variation**

1-7-5

**Type of Chord**

Major
Minor
Seventh
Minor Seventh

**Rhythms Effected**

March, Waltz, Swing, Bossanova
Slow Rock, Rhumba, Samba
March, Waltz, Swing, Bossanova
Slow Rock, Rhumba, Samba

**Bass Notes Played**

1-5

1-3-5

1-5

1-7-5

**Explanation:** This selector effects only the Slow Rock, Rhumba and Samba rhythms when a seventh or minor seventh chord is being played, with which you will hear the root (1), seventh (7), and fifth (5) bass notes. When playing a major or minor chord the unit will perform exactly as it does with the second Bass Variation selector (1-3-5). Remember, the Jazz Rock rhythm is not affected by the Bass Variation selector; it plays only the root (1).

### ● Sounds and Effects

To completely familiarize yourself with the various sounds and effects possible with the Auto Bass/Chord, hold the G7 chord down and try changing the Rhythm buttons (*example: Swing to Bossanova to Samba*). With each change, try each of the three Bass Variation buttons and listen to the bass pedal pattern changes. While you're experimenting with the rhythm patterns, use the Volume knob (*upper left*) to increase and reduce the volume of the Auto Rhythm Section and listen to the changing balance between the percussive rhythms and the chords and pedals. Strive for a good balance. The speed of your rhythm accompaniments can be controlled precisely with the use of the Tempo control and will depend on your musical taste and ability to maintain the tempo (*speed*) of the right hand melody.

### ● Synchro-Start

When the Synchro-Start selector is in the "ON" position, the red light will blink the speed of the rhythm. When the rhythm is playing, the red light will blink on the first and sometimes the first and third beats of the measure depending on the rhythm chosen.

### ● Rhythm and Registrations

The suggested rhythms and registrations are only suggestions and other rhythms and registrations may be used. It is fun to experiment with rhythm and sound. However, when the fraction at the beginning of the song is 3/4, only the Waltz rhythm should be used.

Try changing rhythms in the same song. When changing rhythm in a song the rhythm used must remain at the same tempo (*speed*). Both Swing and Slow Rock are the same speed and can be used interchangeably. The Jazz Rock, Bossanova, Rhumba and Samba are all the same speed and can be used interchangeably.

The rhythms that use three bass pedals (*notes*) are Slow Rock, Rhumba and Samba. To use the three bass pedals, the Bass Variation selector must be    or    with the Auto Bass/Chord lever placed in the "ON" position.

### ● To Play a Melody

Pull forward all the tone levers for both the lower and upper manuals and add the Bass 16' for the Pedals. (NOTE: *The Auto Bass/Chord should be "OFF" at this time*). Play the melody on the upper manual by following either the numbers or letters. (NOTE: *Both "play by number" and "play by letter" systems are used to permit non music readers to enjoy playing the different types of chord organ books available.*)

Add the left hand chords, shown over the melody, on the lower manual and hold each chord until the next chord is shown. (NOTE: *When the Auto Bass/Chord is added, the left hand chords will play in rhythm.*)

### To Play in Rhythm

Press the Swing selector button on the Auto Rhythm Section. To play with the Auto Bass/Chord, pull the Auto Bass/Chord lever forward to "ON". Set the Synchro-Start switch to "ON" and the Start switch to "OFF".

Watch the blinking red light to determine the Tempo of the rhythm. Adjust the Tempo to SLOW in the beginning. Play the melody and when you play the left hand chord C, both the left hand and bass pedal will start to play in rhythm.

### WHEN THE SAINTS GO MARCHING IN

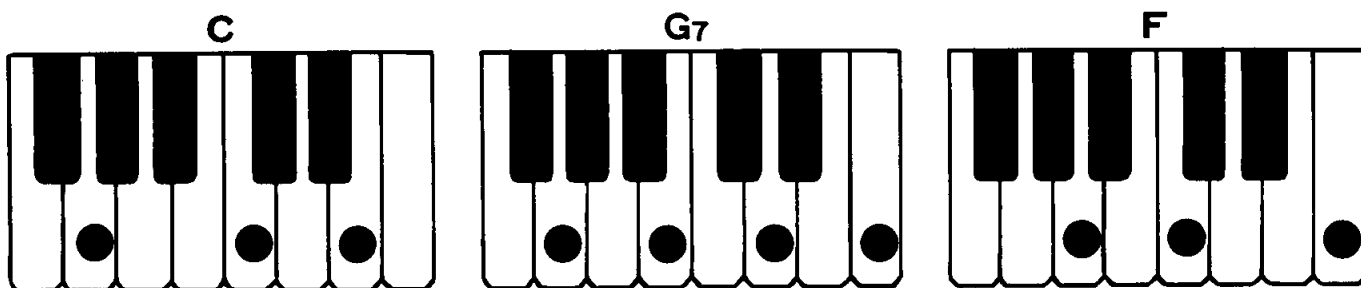

Moderately C Traditional

Oh, WHEN THE SAINTS, \_\_\_\_\_ GO MARCH-ING IN, \_\_\_\_\_ Oh, WHEN THE

G7 C

SAINTS GO MARCH - ING IN, \_\_\_\_\_ Oh, Lord, I want to be in that

# To Play in Rhythm

## ALOHA OE

Rhythm : Swing

Bass Pattern :

L.H. Chords Used In This Song

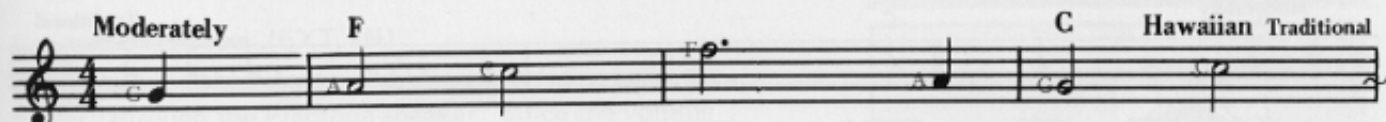
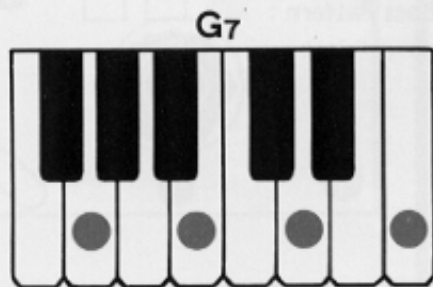
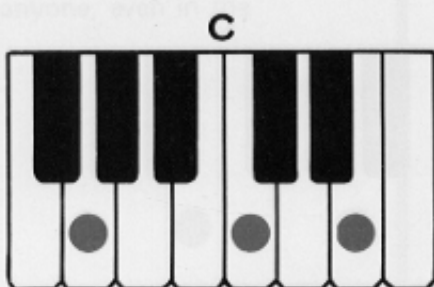
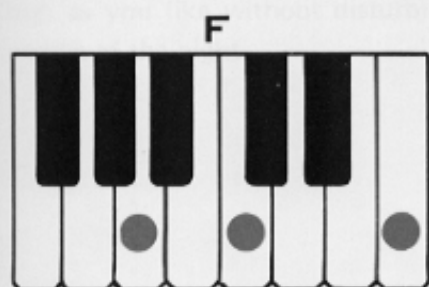

## LA PALOMA

Rhythm : Rhumba

Bass Pattern :

L.H. Chords Used In This Song

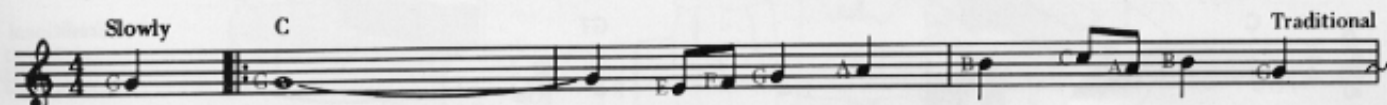
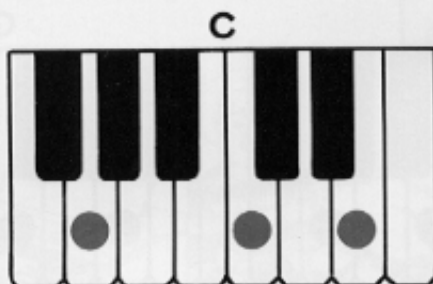

## LONESOME ROAD

Rhythm : Bossanova

Bass Pattern :

L.H. Chords Used In This Song

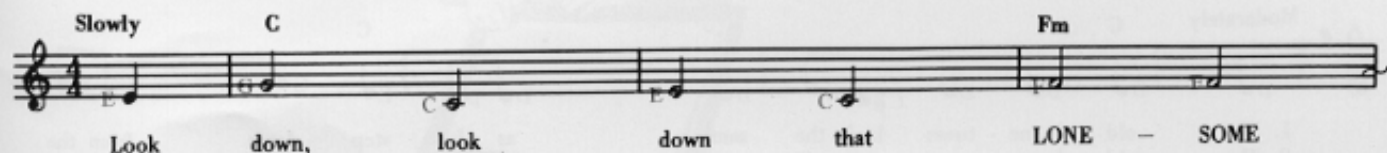
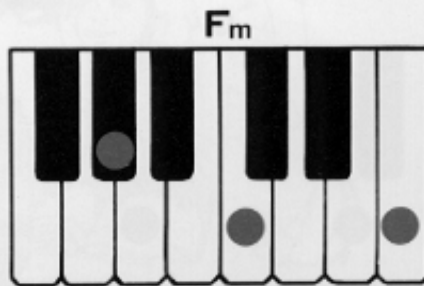
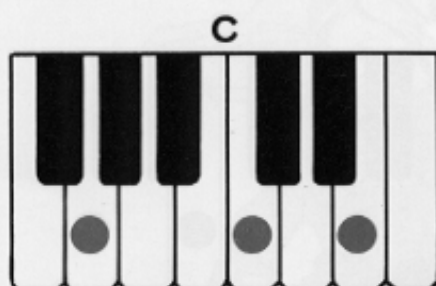

# HE'S GOT THE WHOLE WORLD IN HIS HANDS

Rhythm : Jazz Rock

L.H. Chords Used In This Song

Bass Pattern :

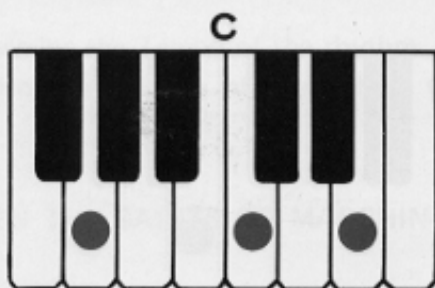

Moderately Traditional

C

HE'S GOT THE WHOLE WORLD IN HIS HANDS; He's got the

# MARIANNE

Rhythm : Slow Rock

L.H. Chords Used In This Song

Bass Pattern :

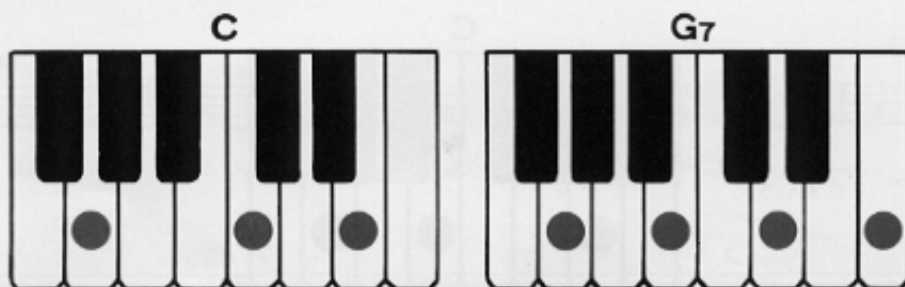

Moderately Traditional

C G7

All day, all night, MARIANNE,

# GREEN GREEN GRASS OF HOME

Rhythm : Swing

(Optional : Slow Rock/Jazz Rock)

L.H. Chords Used In This Song

Bass Pattern :

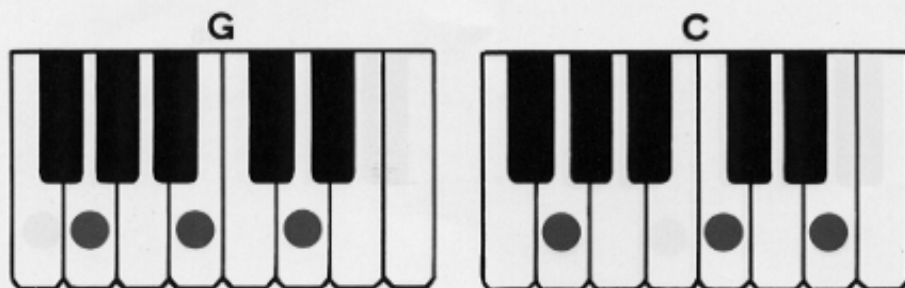

Moderately Traditional

G C

1. The old home town looks the same as I step down from the  
2. The old house is still standing, tho' the paint is cracked and

# To Fully Enjoy Your Electone

## Headphone Jack

Plug a headphone set (optional accessory) into the jack under the keyboard and you can play with the volume as high as you like without disturbing anyone, even in the middle of the night.

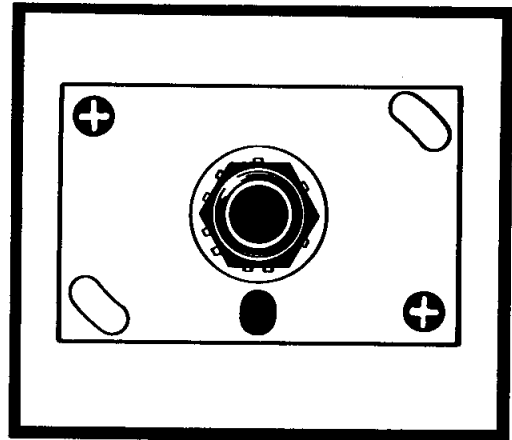

## External Input Jack (EXT. IN)

This is used to feed any sound source (i.e., Tape recorder) through the Electone speaker. Since the volume of the sound sources is not affected by the expression pedal, you can play along on the Electone with any other performance.

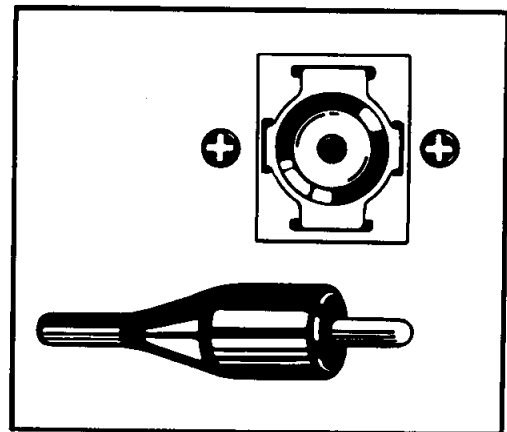

# Care of Your Electone

In general, treat your Electone with the same care you would any fine musical instrument. The following points are suggested for optimum enjoyment.

1. Use only proper line voltage. Consult your Yamaha serviceman for changes.

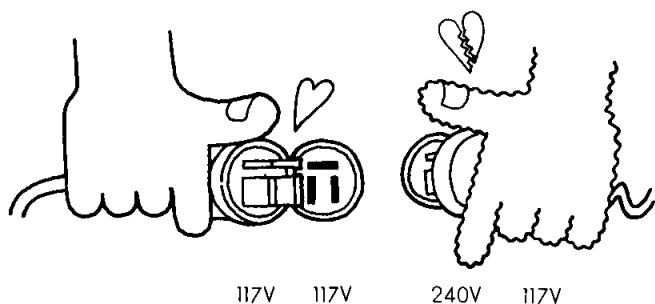

2. Never touch the inside parts yourself.

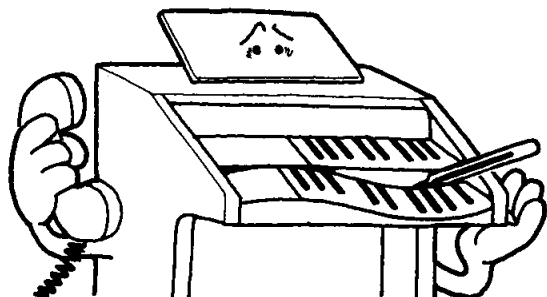

3. Always shut off the power after playing.

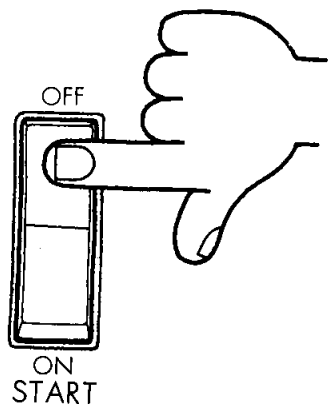

4. Clean keys, etc, with a damp cloth only. Never use solvents such as gasoline; they will damage the finish.

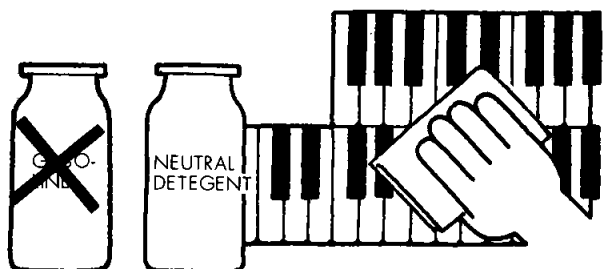

5. Shield the cabinet from direct sunlight, humidity and heat to protect the finish and joints.

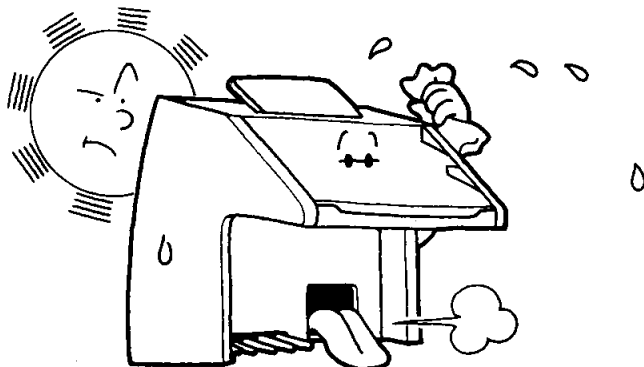

6. Do not hit or scratch the cabinet with a hard object.

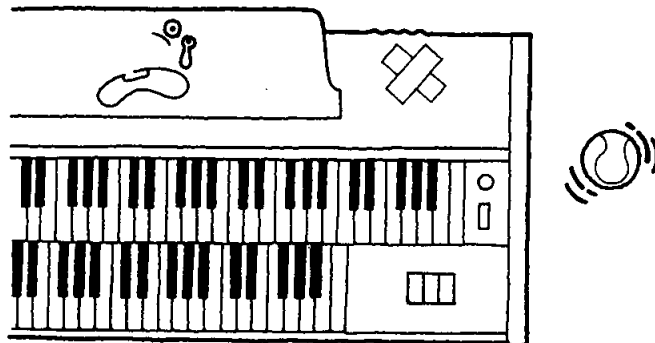

7. To open or close the fallboard grasp the front lip with both hands and slide gently. Never pull directly upwards. Do not place anything heavy on the fallboard.

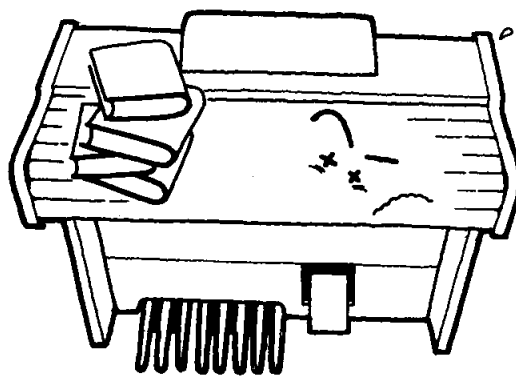



# Do Not Be Alarmed If

1. A note should sound the instant you turn on the switch.

This merely indicates normal operation consequent to a surge of electricity in the main amplifier.

2. Only one note is produced even when two pedals are depressed simultaneously.

In order to achieve tonal clarity, the Electone is designed so that a note is electronically cancelled the instant the next note is struck. If two pedals are struck simultaneously, only the higher one sounds.

3. Occasional unpleasant static occurs.

In the majority of such cases, the cause can be traced to the turning on or off of refrigerators, washing machines, electric pumps or other household appliances. Electrical fault in a neighboring outdoor neon sign may also be to blame.

When the cause is a home appliance, connect the Electone to an outlet as far as possible away from the offending appliance. This phenomenon, although annoying, poses no danger to the Electone circuitry. If the cause is a fault in a neon or fluorescent lighting fixture, it should be repaired. When the cause is unknown, or in case of doubt, contact your Yamaha dealer.

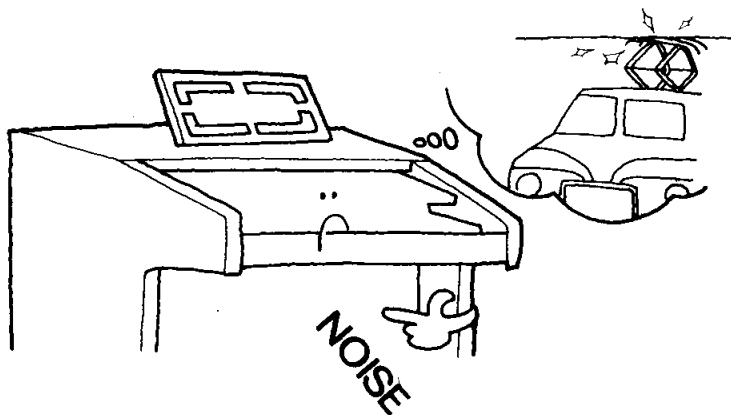

4. The Electone reproduces radio or TV signals.

If there is a powerful transmitter such as radio station in the vicinity this can occur. Contact your Yamaha dealer.

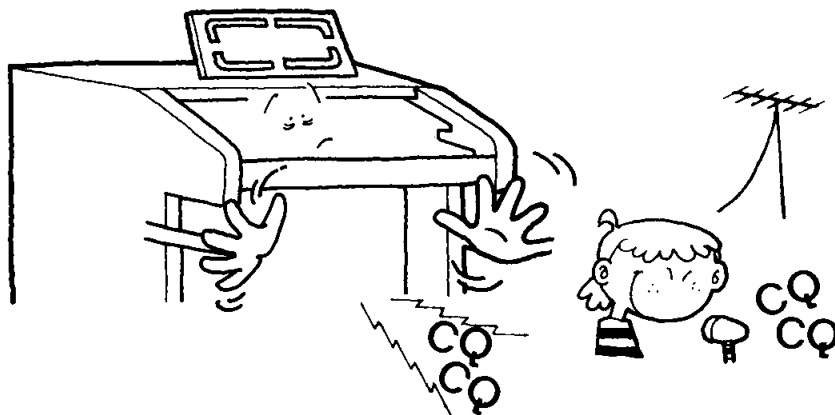

5. Rattling (sympathetic vibration) occurs.

All materials have critical resonance frequencies at which they vibrate. The Electone's continuous tones will naturally cause other objects (windows, shelves, etc.) to vibrate.

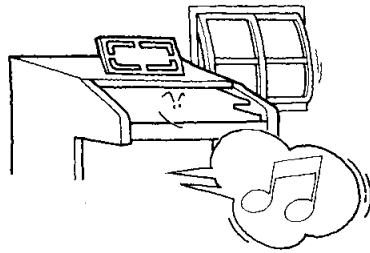

6. Pedal notes sound too high, upper manual notes too low. This is especially noticeable when comparing the Electone and piano. Piano tones are combinations of harmonics and must interact with their surroundings, while Electone harmonics are simpler (multiples of the fundamental tone), requiring the Electone to be adjusted differently.

7. The set does not go on when the power switch is turned on. Check the following:

Is the AC plug fully inserted into the electric wall outlet? Reinsert it to be sure.

Is there power coming from that outlet? —Unplug the Electone and plug in a lamp; switch it on to check that it lights. If it does not the problem is probably in your household electric system. Check your fuses or circuit breakers.

If there is power in the outlet but the Electone does not play, unplug the cord and contact your Yamaha dealer. There are NO USER-SERVICEABLE PARTS inside.

# Specifications

## ■ KEYBOARDS

Upper Manual	44 keys	f ~ c <sub>4</sub> (3 $\frac{3}{8}$ octaves)
Lower Manual	44 keys	F ~ c <sub>3</sub> (3 $\frac{3}{8}$ octaves)
Pedals	13 keys	C <sub>1</sub> ~ C (1 octave)

## ■ TONE LEVERS

Upper Manual	Flute	16'
	Flute	8'
	Flute	4'
	Trombone	16'
	Brass	8'
Lower Manual	String	8'
	Flute	8'
	Horn	8'
Pedals	Cello	8'
	Bass	16'
	Bass Guitar	

## ■ PRESET TONE SELECTORS (UPPER)

Piano  
Hawaiian Guitar

## ■ EFFECT LEVERS

Vibrato  
Percussive 4' (Upper)  
Percussive Length (Upper)  
Attack Wah-Wah (Upper)  
Repeat Speed (Upper)  
Pedal Sustain

## ■ EFFECT CONTROLS

Brilliance  
Reverb  
Manual Balance (Upper/Lower)

## ■ EFFECT SELECTOR

Glide (Foot control)

## ■ TREMOLO SELECTORS

Voice (Main/Rotary)  
Ensemble  
Tremolo  
Chorus

## ■ AUTO RHYTHM SECTION

Rhythm Selectors  
March Jazz Rock  
Waltz Rhumba  
Swing Bossanova  
Slow Rock Samba  
Rhythm Controls

Rhythm Start  
Synchro-Start  
Rhythm Stop (Foot control)  
Tempo  
Volume  
Tone Balance  
Tempo Indicator Lamp

## ■ AUTO ACCOMPANIMENT SECTION

Auto Bass/Chord Lever  
Bass Variation Selectors  
1 · 5  
1 · 3 · 5  
1 · 7 · 5

## ■ OTHER CONTROLS

Master Volume  
Expression Pedal  
Foot Effect Switch  
Tremolo Speed Control  
Power Switch

## ■ OTHER FITTINGS

Headphone Jack  
External Input Jack  
Pilot Lamp  
Roll-top Fallboard  
Music Rest  
Matching Bench with Music Storage Space

## ■ NATURAL SOUND SPEAKERS

Main: JA-5101A 59 x 48cm (23  $\frac{1}{4}$  x 14  $\frac{1}{2}$ "")  
Rotary: JA-1701A 16 x 23cm (6  $\frac{1}{2}$  x 9")  
Electro-control 2-speed

## ■ CIRCUITRY

Solid State (Incl. ICs and FETs)  
Main Amplifier: OCL System  
Output Power: 30 Watts (RMS)  
Power Consumption: 120 Watts  
Power Source: 100/110/117/125/220  
240V AC 50/60Hz

## ■ DIMENSIONS

Width: 112cm (44")  
Depth: 56cm (22")  
Height: 90cm (35  $\frac{1}{2}$ "")

■ WEIGHT BK-7 BK-7I, S  
58kg (128 lbs.) 60kg (132 lbs.)

## ■ FINISH

BK-7, BK-7I: Natural American walnut,  
oil finish  
BK-7S: Antique oak, oil finish

*Specifications subject to change without notice.*

## Special Instructions for British-Standard Model

As the colours of the wires in the mains lead of the apparatus may not correspond with the coloured markings identifying the terminals in your plug proceed as follows.

The wire which is coloured GREEN-and-YELLOW must be connected to the terminal in the plug which is marked by the letter E or by the safety earth symbol  or coloured GREEN or GREEN-and-YELLOW.

The wire which is coloured BLUE must be connected to the terminal which is marked with the letter N or coloured BLACK.

The wire which is coloured BROWN must be connected to the terminal which is marked with the letter L or coloured RED.

## IMPORTANT

THE WIRES IN THE MAINS LEAD ARE COLOURED IN ACCORDANCE WITH THE FOLLOWING CODE.

GREEN-AND-YELLOW: EARTH  
BLUE: NEUTRAL  
BROWN: LIVE

## WARNING:

THIS APPARATUS MUST BE EARTHED.

SINCE 1887



**YAMAHA**

NIPPON GAKKI CO., LTD. HAMAMATSU, JAPAN