



YAMAHA CORPORATION
P.O. BOX1, Hamamatsu Japan
www.yamahaproaudio.com
*All specifications are subject to change without notice. *All trademarks and registered trademarks are property of their respective owners.



AFC3
ACTIVE FIELD CONTROL

For over 125 years YAMAHA craftsmen have created some of the world's finest musical instruments. Superior sound quality has always been the driving force behind all of Yamaha's efforts. Whether manufacturing instruments, developing state-of-the-art audio technologies or designing performance halls and theatres, Yamaha is always seeking new ways to deliver the best possible listening experience.

First implemented by Yamaha in 1985, Active Field Control (AFC) is an acoustic conditioning system designed to adjust and enhance the architectural acoustic characteristics of facilities such as performance arts venues, houses of worship, theatres and concert halls—while maintaining the natural sonic characteristics of the space.

AFC3 represents the third generation of innovative Active Field Control (AFC) systems from Yamaha, the most trusted name in audio.

With increasing pressure for facilities to become more multi-purpose and accommodate a wider range of applications AFC3 provides a cost-effective alternative to mechanical means of modifying room acoustics. A truly scalable solution which can be installed in a wide range of venues AFC3 makes it possible to hold classical concerts in a very large hall without a sound reinforcement system, to accommodate an organ in a small church, or to enhance crowd response in a stadium. Reverberation changes can be made at the push of a button, allowing the performance environment to be adjusted almost instantly. In addition AFC3 is able to deliver the same high-quality sonic experience to every performer and member of the audience.

Yamaha AFC systems are currently installed in over 80 facilities in the U.S. And Japan, and now with the release AFC3, a much wider range of facilities worldwide will now have access to the best acoustic enhancement system available today.



What is AFC ?

Active Field Control is an acoustic enhancement system that is used to improve or enhance the architectural acoustic characteristics of a room and optimize reverberation while preserving that room's natural acoustic 'signature'. Yamaha DSP technology enables us to realize this system with a small set of core devices.

AFC adjusts acoustical conditions by using an acoustical feedback system which makes AFC different from, and superior to, other techniques that are based on the use of digital reverbs to simulate room characteristics.

Key Features

- ▶ Variable settings for different performances
- ▶ Preservation of natural acoustics
- ▶ Simple end-user control
- ▶ Cost-effective solution



AFC Concept

Increasing the sound energy density can extend the reverberation time in a room.

AFC utilizes the acoustical feedback of a system to increase the energy density of diffused sound. Reverberation time and sound energy density can be controlled with transparency while preserving the original acoustical characteristics of a room.

This technique distinguishes AFC from other enhancement systems.

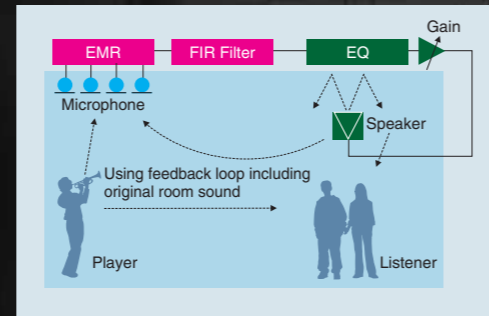

EMR (Electronic Microphone Rotator)

Since AFC utilizes acoustical feedback, it is essential to prevent coloration problems caused by a closed loop condition and maintain a stable system. In order to ensure controlled loop gain and a sufficient margin against instability, AFC implements a special patented technique called Electronic Microphone Rotator (EMR).

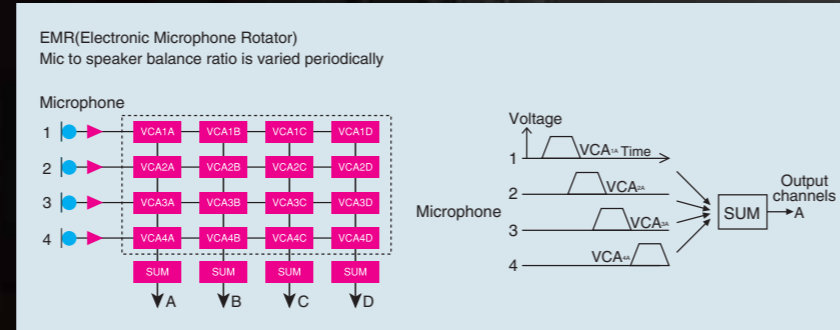

AFC3 Core Unit

The AFC3 core unit is based on Yamaha's well-known DME64N digital mixing engine. The enhanced AFC3 version of this processor includes the expected matrix mixers, delay lines, parametric EQ's, and routing functions as well as specialized DSP components developed specifically for AFC applications. While one card slot of the AFC3 processor hosts a card dedicated to the FIR processing functions, the remaining three MY-card slots provide the first 22 channels of outputs to the AFC system. Additional AFC3 units may be added and linked to the master unit for additional outputs.



AFC FIR Card

The AFC-FIR card is used to realize the high density of FIR processing that was not previously possible. AFC3 systems with the AFC-FIR card are capable of working with FIR filter sets that contain 125 times as many taps as previous AFC systems. This increase in the size and density of the FIR filter sets available make it possible to achieve much longer increases in a room's natural reverberation time without unnatural sounding artifacts.



Product List

Equipment	Num. of Units	ItemBL	Description
1	4		Omni-Directional Type
2	1	AD8HR	8 ch HA-AD Unit
3	2	AFC3	AFC Signal Processor
4	1	AFC FIR Card	4 ch FIR Card
5	6	MY8-DA96	8 ch DA Card
6	1	CAS003	
7	6	(Breakout Cable)	
8	11	XMV4140	Power Amp 4 ch
9	8	IF2205	2-Way, Passive Mode, with 2 x 5" Woofer
10	36	VXC8	8" Coaxial 2 Way Bass Reflex
11	2	ICP1	

Block diagram

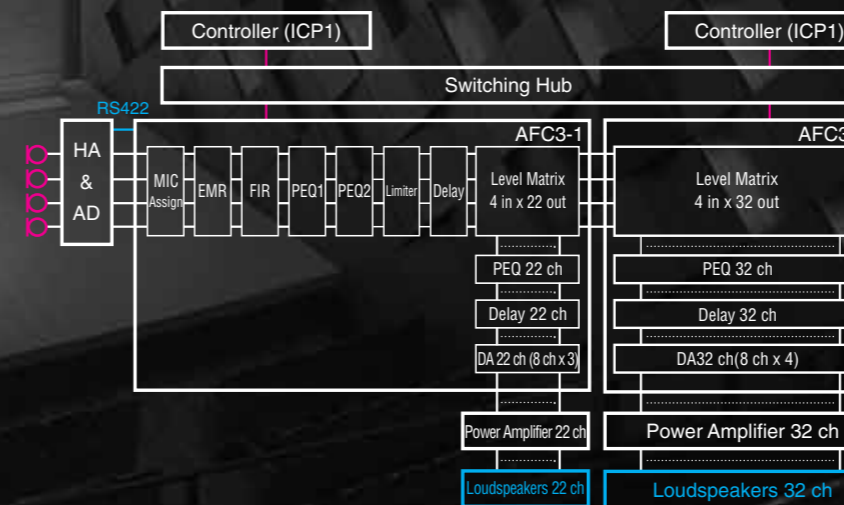

System Configuration

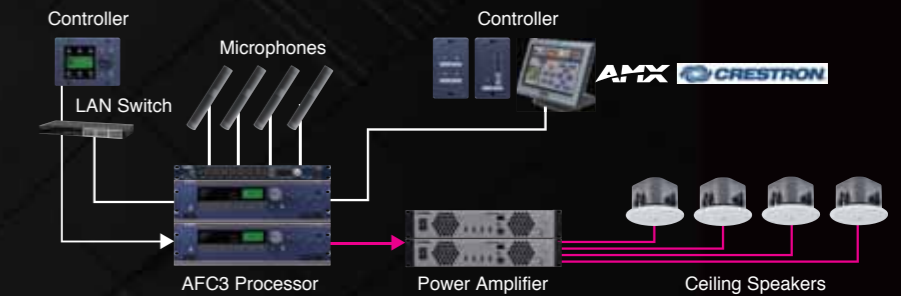

Speaker and Microphone Arrangement

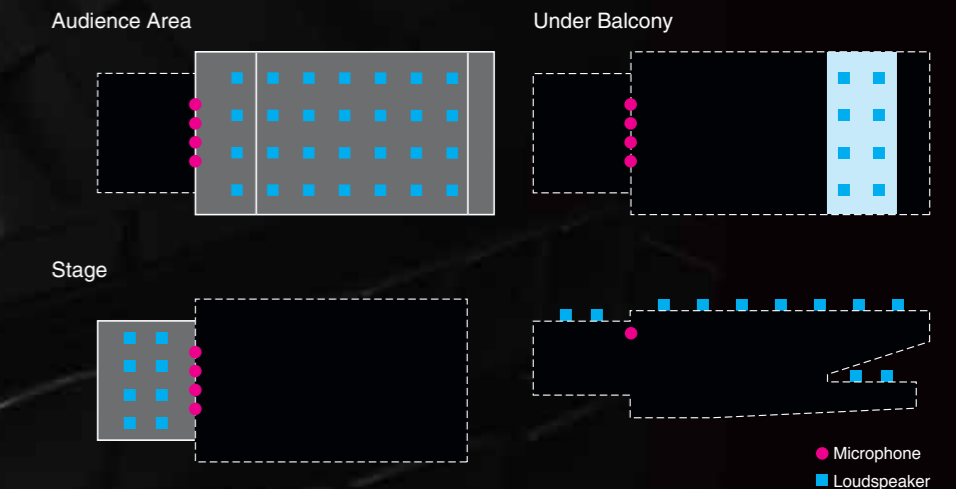

AFC Projects

Tokyo International Forum, Tokyo, Japan

The main auditorium of Tokyo International Forum, with more than 5000 seats, is one of the largest auditoriums in Japan and the Asia region. AFC systems have been installed in the venue to support live musical performances such as classical concerts. The challenge is to provide sufficient sound levels in such a large space. The AFC systems are used to enhance early reflections, increase the overall sound level, extend reverberation times, and ensure consistency throughout the venue, including the under-balcony areas. The facility has been used as the main venue for international musical events such as “La Folle Journee,” which is held every May.



Seating Capacity	5,008
Completion Year	1997 Renovated 2010
Volume (m ³)	54,980
Volume/Seat	11.0
System	Reverberation (Reverberation & Warmth) Early Reflection (Presence, Spaciousness, Lateral Reflection, Under balcony)
Number of Speakers	REV: 85, ER: 112
Number of Microphones	REV: 16, ER: 4
RT off (Sec)	1.9
RT on (Sec)	3.3

Miller Auditorium at Western Michigan University, Kalamazoo, MI

Miller auditorium originally opened in 1968 and was renovated in 2007. The renovations included the addition of AFC systems to improve the acoustical environment without architectural changes to the space. The School of Music at Western Michigan University uses this auditorium for their major concerts and rehearsals. The auditorium also hosts the Kalamazoo Symphony Orchestra for their subscription series concerts and a wide array of theatrical and musical events.



Seating Capacity	3,485
Completion Year	2007
Volume (m ³)	42,100
Volume/Seat	12.1
System	Reverberation & Energy Exchange
Number of Speakers	REV: 62, EEX: 8
Number of Microphones	REV: 8, EEX: 4
RT off (Sec)	1.7
RT on (Sec)	2.8

Ito Memorial Hall at Tokyo University, Tokyo, Japan

The auditorium, opened in 2012, was designed primarily for meeting lectures and has a characteristically modest reverberation time. However, the auditorium is also used for classical and contemporary music. An AFC system is installed to enhance reverberation for these applications and can increase reverberation times to greater than three times the room’s natural RT.



Seating Capacity	489
Completion Year	2011
Volume (m ³)	1,990
Volume/Seat	4.1
System	Reverberation
Number of Speakers	24
Number of Microphones	4
RT off (Sec)	0.8
RT on (Sec)	2.3

High School Auditorium for Whitney Point Central School District, Whitney Point, NY

The auditorium was originally built approximately 50 years ago and renovated in 2011. Designed for meetings and lectures, intelligibility is very important. However, the auditorium is also used for musical events of different types, and AFC helps adjust the acoustics to support these concerts. Project Manager Fred J. Riordan says, “Whitney Point is very pleased with the Yamaha AFC system; the quality of sound is magnificent, and the system and acoustics create a truly exceptional listening experience.”



Seating Capacity	490
Completion Year	2011
Volume (m ³)	3,205
Volume/Seat	6.5
System	Reverberation
Number of Speakers	28
Number of Microphones	4
RT off (Sec)	1.4
RT on (Sec)	1.8